

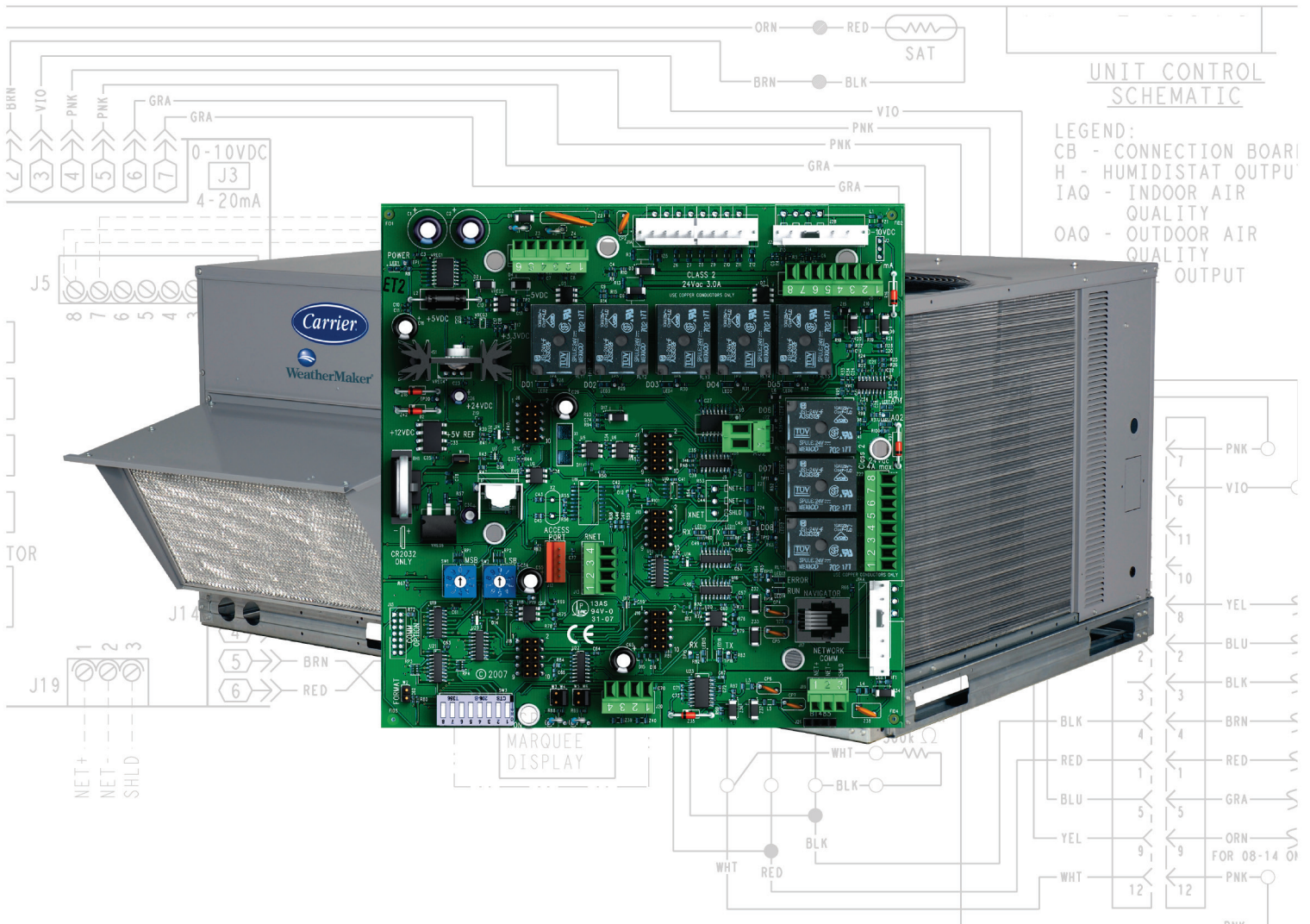

United Technologies
turn to the experts

RTU Open v3

Installation and Start-up Guide





Verify that you have the most current version of this document from www.hvacpartners.com or your local Carrier office.

Important changes are listed in **Document revision history** at the end of this document.

CARRIER CORPORATION ©2017. All rights reserved throughout the world. i-Vu is a registered trademark of Carrier Corporation. All other trademarks are the property of their respective owners.

Contents

Introduction.....	1
What is the RTU Open controller?	1
Specifications	3
Safety considerations.....	4
Installing the RTU Open.....	5
Field-supplied hardware	5
To mount the RTU Open.....	6
To wire the controller for power.....	7
To use the rooftop equipment control power transformer.....	7
To use an auxiliary control power transformer	8
To set the controller's address.....	9
To set the controller's communications protocol and baud rate	10
Wiring for communications.....	10
Wiring specifications for BACnet MS/TP and ARC156.....	11
To wire the controller to the BACnet network	11
Wiring inputs and outputs	12
Input wiring specifications	13
Inputs	14
Binary outputs	14
Analog outputs	14
To wire inputs and outputs	15
Wiring sensors and switches to the controller	19
Field-supplied sensor hardware	20
Wiring devices to the RTU Open's Rnet port	21
Wiring a Supply Air Temperature sensor.....	27
Wiring a duct air temperature sensor	28
Wiring an outdoor air temperature sensor	29
Wiring a CO2 sensor.....	30
Wiring an outdoor air quality sensor	31
Wiring a relative humidity sensor	32
Wiring a Humidistat.....	33
Wiring an enthalpy switch	34
Wiring a status switch	37
Wiring a compressor safety	38
Wiring an occupancy switch or door contact	39
Start-up.....	41
Service Test.....	41
Configuring the RTU Open's properties	43
Sequence of Operation	44
Occupancy.....	44
Supply fan	45
Cooling.....	45
Economizer	46
Power Exhaust.....	47
Pre-Occupancy Purge	47
Unoccupied Free Cooling.....	47
Optimal Start	48
Enthalpy control	49
Indoor Air CO2	49
Heating.....	50
Heat Pump operation.....	50
Dehumidification	51

Demand Limiting	51
Door switch	51
Remote Occupancy	52
Fire Shutdown	52
Compressor Safety	52
Fan Status.....	52
Filter status.....	53
Alarms	53
Linkage.....	55
Linkage air source mode determination.....	57
Troubleshooting	58
Communication LED's.....	58
To get the serial number	59
To replace the RTU Open's battery.....	59
Compliance	60
FCC Compliance.....	60
CE Compliance	60
BACnet Compliance.....	60
Appendix A: RTU Open Points/Properties in I-Vu®/Field Assistant	61
Status.....	61
Unit Configuration.....	62
Setpoints	69
Alarm Configuration	75
Service Configuration	77
Maintenance.....	80
Performance.....	83
Alarms	85
Linkage.....	87
I/O Points.....	88
Appendix B: Single Point Linkage and Device Address Binding	90
Single Point Linkage	90
Device Address Binding.....	91
Appendix C: RTU Open Points/Properties on the Equipment Touch	92
Navigation screens	92
Startup Wizard	94
Status - Equipment Touch	96
Unit Configuration - Equipment Touch.....	97
Setpoints - Equipment Touch.....	99
Alarm Configuration - Equipment Touch.....	100
Maintenance - Equipment Touch	101
Performance - Equipment Touch.....	103
Alarms - Equipment Touch	103
Document revision history	106

Introduction

What is the RTU Open controller?

The RTU Open controller (part# OPN-RTUM2) is available as an integrated component of a Carrier rooftop unit, or as a field-installed retrofit product.

NOTE The RTU Open controller is available in both English or Metric units. The metric version has (-M) appended to the part number. Everything in this document applies to both versions.

Its internal application programming provides optimum rooftop performance and energy efficiency. RTU Open enables the unit to run in 100% stand-alone control mode or it can communicate to the Building Automation System (BAS).

The RTU Open supports the following:

- **SPT, ZS, and Carrier wireless sensors** - Models are available for monitoring space temperature, space relative humidity, and space IAQ/CO2. Sensors provide:
 - Space setpoint offset adjustment
 - Pushbutton override
 - Occupancy indicator
- **BACnet and third party protocols** - On-board DIP switches allow you to select the baud rate and choose one of the following protocols:
 - BACnet MS/TP
 - BACnet ARC156
 - Modbus
 - Johnson N2
 - LonWorks
- **Mixed systems** - Supports CCN air terminals using Linkage to BACnet RTU Open Air Source
- **California Title 24** - Includes advanced Fault Detection and Diagnostic Logic for Economizer Operation in accordance with California Title 24 requirements
- **Equipment Touch** - The Equipment Touch is a user interface that is a touchscreen device with a 4.3 in. color LCD display that you connect to the RTU Open (driver v6.00:082 or later) to view or change property values, equipment schedules, trends and alarms, and more, without having to access the system's i-Vu® server.

The RTU Open's application supports detailed color graphics, status, properties, alarms, trends, performance, configuration, and Help on the Equipment Touch. In addition, an RTU Open *Startup Wizard* (page 94) has specific screens to facilitate initial RTU Open configuration.

For more details about the Equipment Touch, see the *Equipment Touch Installation and Setup Guide*.

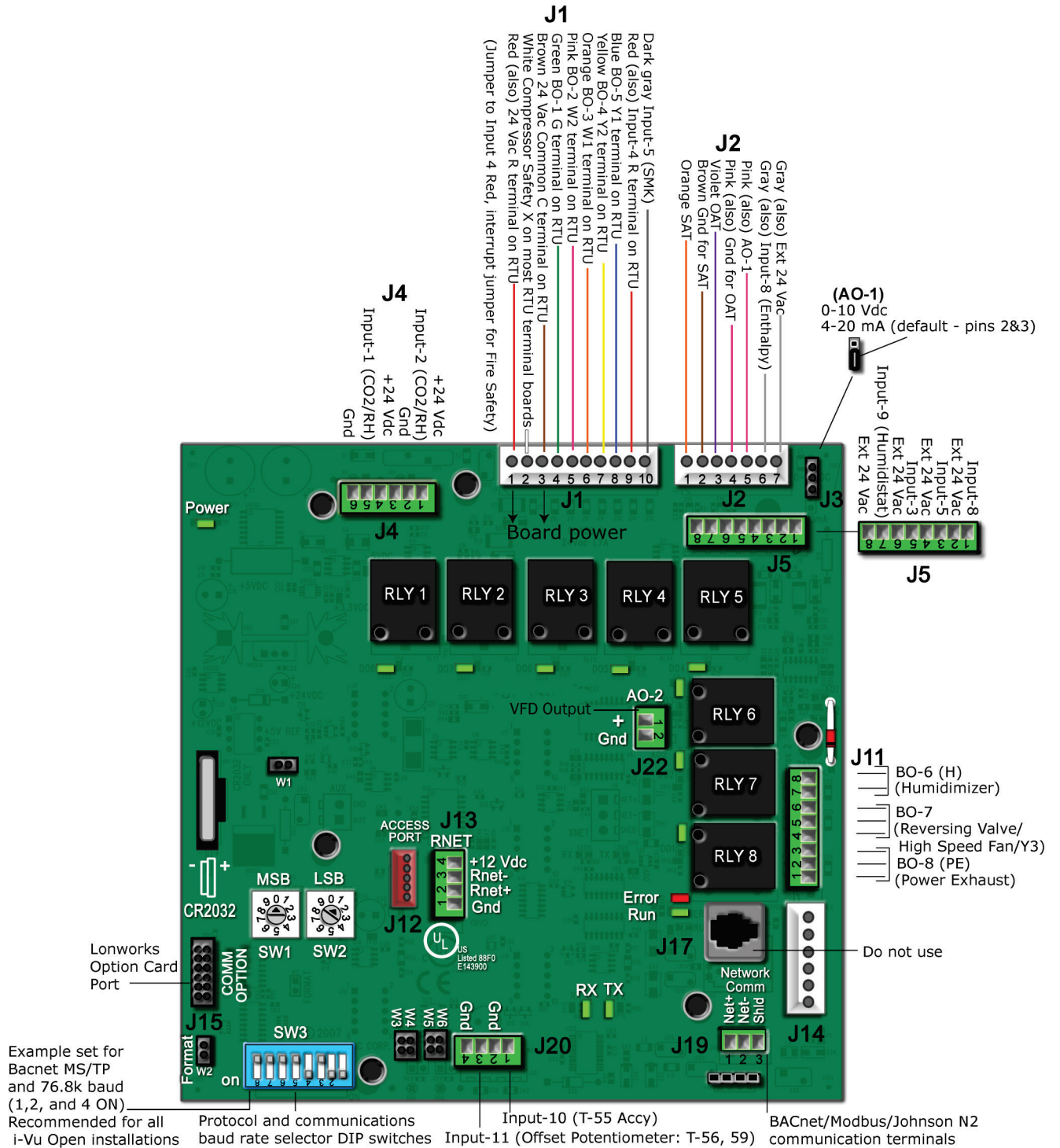

Specifications

Driver	drv_rtuopn_std_x-xxx-xxx
Power	24 Vac \pm 10%, 50–60 Hz 20 VA power consumption 26 Vdc (25 V min, 30 V max) Single Class 2 source only, 100 VA or less
Access port J12	To connect to Field Assistant
Rnet port J13	Supports SPT or ZS sensors, Wireless Adapter for wireless sensors, or the Equipment Touch <ul style="list-style-type: none"> Any combination of 1 - 5 SPT sensors Any combination of 1 - 15 ZS sensors, plus an Equipment Touch or Wireless Adapter for wireless sensors NOTE You cannot have more than 5 ZS sensors per control program 1 Equipment Touch per Rnet <p>NOTES</p> <ul style="list-style-type: none"> Equipment Touch requires 24 Vac and cannot be powered by Rnet's 12 Vdc. For more details, see the <i>Equipment Touch Installation and Setup Guide</i>. You cannot have an SPT sensor on the same Rnet as a ZS sensor, Wireless Adapter for wireless sensors, or the Equipment Touch.
Network Comm port J19	For communication with the controller network using BACnet ARC156 (156 kbps) or BACnet MS/TP (9600 bps – 76.8 kbps)
Comm Option port	For communication with the LonWorks Option Card.
Inputs	12 inputs: <ul style="list-style-type: none"> Inputs 1 - 2: 4-20 mA only Inputs 3, 5, 8, 9: Binary, 24 Vac Inputs 6 - 7: Thermistor Inputs 10 - 11: Thermistor Rnet sensor
Binary outputs	8 relay outputs, contacts rated at 3 A max @ 24 Vac. Configured normally open.
Analog outputs	<ul style="list-style-type: none"> AO-1: 2-10 Vdc or 4-20 mA (configurable on jumper J3) AO-2: 0-10 Vdc or 2-10 Vdc SC-VFD input
Output resolution	10 bit D/A
Real-time clock	Battery-backed real-time clock keeps track of time in event of power failure
Battery	10-year Lithium CR2032 battery retains the following data for a maximum of 10,000 hours during power outages: control programs, editable properties, schedules, and trends.

Protection	<p>Incoming power and network connections are protected by non-replaceable internal solid-state polyswitches that reset themselves when the condition that causes a fault returns to normal.</p> <p>The power, network, and output connections are also protected against transient excess voltage/surge events lasting no more than 10 msec.</p>
Status indicators	LED's indicate status of communications, running, errors, power, and digital outputs
Environmental operating range	<p>-40 to 158 °F (-40 to 70 °C), 10–95% relative humidity, non-condensing</p> <p>NOTE Controllers should be mounted in a protective enclosure.</p> <p>Vibration during operation: all planes/directions, 1.5G @ 20–300 Hz</p> <p>Shock during operation: all planes/directions, 5G peak, 11 ms</p> <p>Shock during storage: all planes/directions, 100G peak, 11 ms</p>

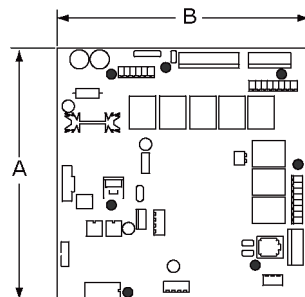

Overall dimensions	<p>A: 6-1/2 in. (16.5 cm)</p> <p>B: 6-1/2 in. (16.5 cm)</p>
Mounting dimensions	7 mounting holes in various positions
Depth	1-11/16 in. (4.3 cm)
Weight	11.2 oz (0.32 kg)
BACnet support	Conforms to the BACnet Advanced Application Controller (B-AAC) Standard Device Profile as defined in ANSI/ASHRAE Standard 135-2012 (BACnet) Annex L, Protocol Revision 9
Listed by	UL-873, FCC Part 15-Subpart B-Class A, CE EN50082-1997

Safety considerations

⚠ WARNING Disconnect electrical power to the RTU Open before wiring it. Failure to follow this warning could cause electrical shock, personal injury, or damage to the controller.

Installing the RTU Open

To install the RTU Open:

- 1 *Mount the controller* (page 6).
- 2 *Wire the controller for power* (page 7).
 - *To use the rooftop equipment control power transformer* (page 7).
 - *To use an auxiliary control power transformer* (page 8).
- 3 *Set the controller's address* (page 9).
- 4 *Set the protocol and baud rate* (page 10).
- 5 *Wire to the BACnet MS/TP or BACnet ARC156 network* (page 10, page 11).
- 6 *Wire inputs and outputs* (page 12).
- 7 *Wire sensors to the controller* (page 19).

Field-supplied hardware

An RTU Open retrofit installation may require the following field-supplied components:

- wiring harness: Part #OPN-RTUHRN
- transformer – 24 Vac, 20 VA minimum
- wiring

Application-dependent components:

- carbon dioxide sensors
- damper/damper actuator
- differential pressure switch
- enthalpy switch
- fan status switch
- door switch
- fan section door switch
- relative humidity sensor
- remote occupancy contact
- smoke detector
- temperature sensors

To mount the RTU Open

⚠ WARNING

When you handle the RTU Open:

- Do not contaminate the printed circuit board with fingerprints, moisture, or any foreign material.
- Do not touch components or leads.
- Handle the board by its edges.
- Isolate from high voltage or electrostatic discharge.
- Ensure that you are properly grounded.

We highly recommend that you mount the RTU Open in the unit control panel!

⚠ WARNING

When you mount the RTU Open:

- Do not locate in an area that is exposed to moisture, vibration, dust, or foreign material.
- Follow NEC and local electrical codes.
- Do not obstruct access for unit maintenance.
- Protect from impact or contact during unit maintenance.

Screw the RTU Open into an enclosed panel using the mounting slots on the cover plate. Leave about 2 in. (5 cm) on each side of the controller for wiring.

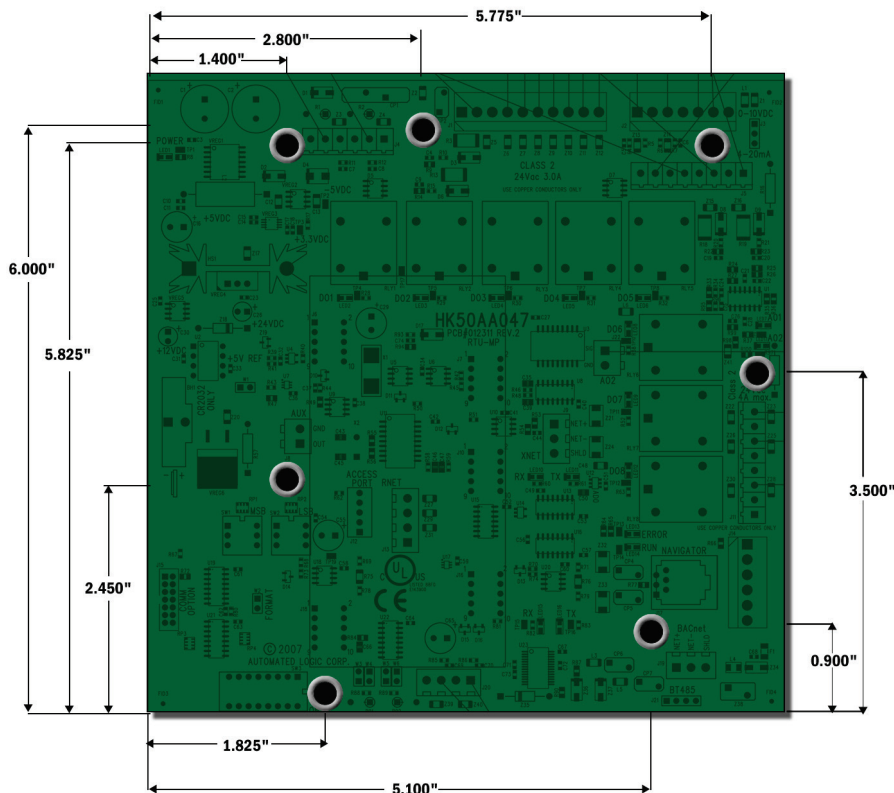

To wire the controller for power



CAUTIONS

- The RTU Open is powered by a Class 2 power source. Take appropriate isolation measures when mounting it in a control panel where non-Class 2 circuits are present.
- Do not power pilot relays from the same transformer that powers the RTU Open.
- Carrier controllers can share a power supply as long as you:
 - Maintain the same polarity
 - Use the power supply only for Carrier controllers
- The RTU Open has an operating range of 21.6 Vac to 26.4 Vac. If voltage measured at the RTU Open's input terminals is outside this range, the RTU Open may not work properly.
- Avoid running communication wires or sensor input wires next to AC power wires or the controller's relay output wires. The resulting noise can affect signal quality. Common sources of noise are:
 - Spark igniters
 - Radio transmitters
 - Variable speed drives
 - Electric motors (> 1hp)
 - Generators
 - Relays
 - Transformers
 - Induction heaters
 - Large contactors (i.e., motor starters)
 - Video display devices
 - Lamp dimmers
 - Fluorescent lights
- In most cases, the RTU Open will be powered from the control power transformer provided with the rooftop equipment. If you must use a separate control power transformer, additional precautions must be taken to ensure that the auxiliary transformer is in-phase with the rooftop equipment's control power transformer. See *Using an auxiliary control power transformer* (page 8).

To use the rooftop equipment control power transformer

- 1 Remove power from the 24 Vac transformer.
- 2 Remove connector assembly from RTU Open's **J1** connector.
- 3 If the rooftop equipment has thermostat connection terminals, connect wiring harness **J1** wire 1 to R, and **J1** wire 3 to C. Alternately, connect the control power transformer wires to **J1** connector wires 1 (24 Vac) and 3 (Gnd).
- 4 Apply power to the rooftop equipment.
- 5 Measure the voltage at the RTU Open's **J1** terminals 1 and 3 to verify that the voltage is within the operating range of 21.6–26.4 Vac.

- 6 Attach harness to RTU Open connector **J1**.

NOTE The harness and connector are keyed and must be oriented properly for correct installation.

- 7 Verify that the **Power** LED is on and the **Run** LED is blinking.

To use an auxiliary control power transformer

If you use a separate control power transformer, it is essential that the auxiliary transformer and the rooftop transformer are in-phase. You **must** verify this prior to connecting the auxiliary transformer to the RTU Open.

Follow these steps:

- 1 Verify the available primary voltage at the rooftop equipment.
- 2 Remove power from the rooftop equipment and install the appropriate auxiliary transformer. Follow the manufacturer's installation instructions.
- 3 Ground one leg of the auxiliary transformer's secondary wiring.
- 4 Apply power to the rooftop equipment. Measure the potential between the rooftop equipment control power and auxiliary transformer's secondary hot (non-grounded) legs. If the voltage measured is less than 5 volts, the transformers are in-phase; proceed to step 7. If you measure a voltage greater than 24 Vac, then the phases are reversed.
- 5 Correct the phase reversal by either of the following methods:
 - o Remove the ground from the secondary at the auxiliary transformer and connect it to the other secondary
 - o Reverse the primary wiring at the auxiliary transformer
- 6 Repeat step 4 to rewire.
- 7 Remove connector assembly from RTU Open's **J1** connector.
- 8 Connect the auxiliary transformer wires to **J1** wires **1** (24 Vac) and **3** (Gnd).
- 9 Apply power to the transformer.
- 10 Measure the voltage at the RTU Open's **J1** - **1** and **3** to verify that the voltage is within the operating range of 21.6–26.4 Vac.
- 11 Attach harness to RTU Open's connector **J1**. See illustration below.

NOTE The harness connectors are keyed and must be oriented properly for correct installation.
- 12 Verify that the **Power** LED is on and the **Run** LED is blinking.

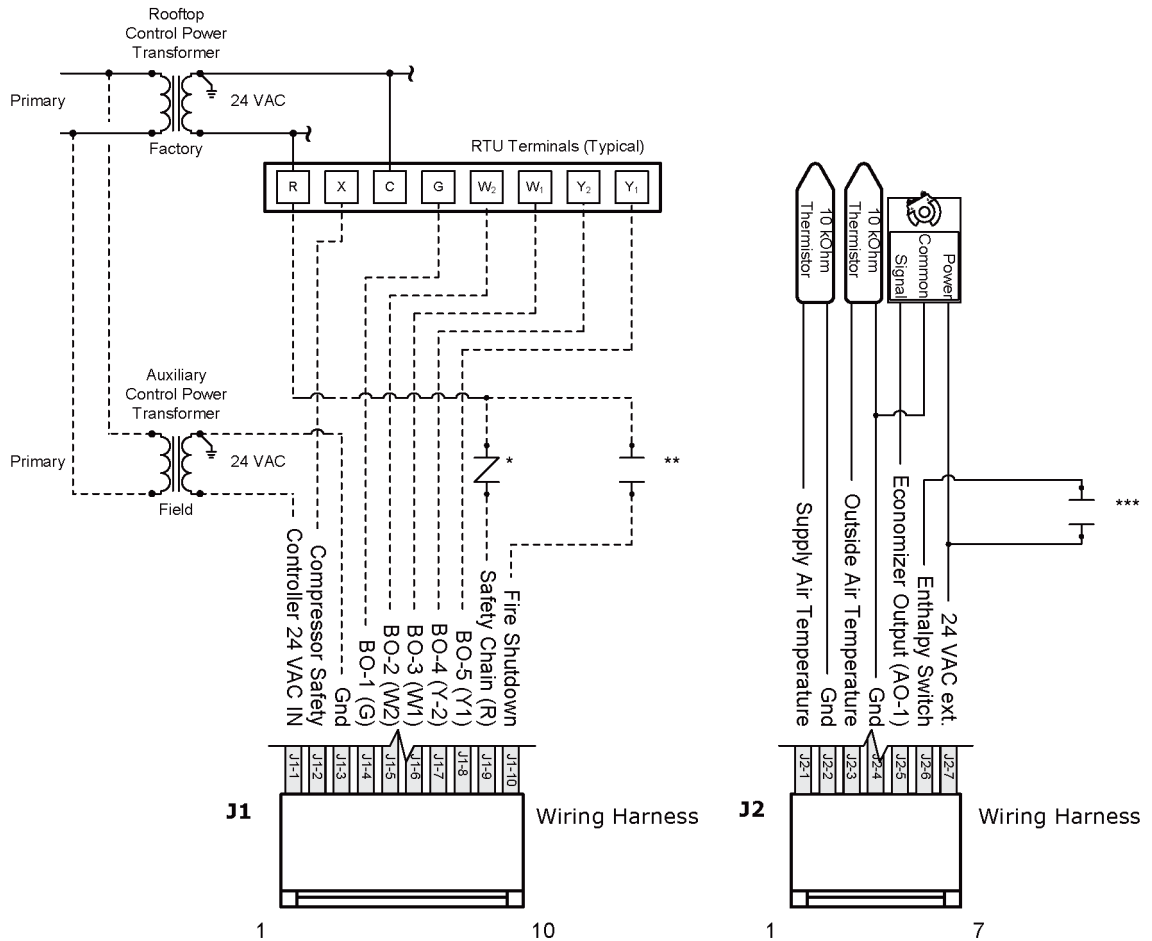

Optional

- * Safety chain devices, field-installed - normally closed. Apply 24 Vac to this terminal (jumper from **J1** - 1 to **J1** - 9) where no safety devices are installed.
- ** Fire shutdown device, field-installed, configurable as normally open or closed
- *** Enthalpy switch, field-installed - configurable as normally open or closed

To set the controller's address

The RTU Open's two rotary switches determine the RTU Open's MAC address when it is placed on an MS/TP network. The rotary switches define the MAC address portion of the RTU Open's BACnet device instance number, which is composed of the MS/TP network number and the MAC address. They also set the slave address on a Modbus or N2 network when less than 100. See the *RTU Open Integration Guide* for additional information on integration.

CAUTION The MAC address of the controller must be unique on its network.

- 1 Turn **off** the RTU Open's power. The controller reads the address each time you apply power to it.
- 2 Using the rotary switches, set the **MSB (SW1) (10's)** switch to the tens digit of the address, and set the **LSB (SW2) (1's)** switch to the ones digit.

EXAMPLE To set the RTU Open's address to 01, point the arrow on the **MSB (SW1)** switch to 0 and the arrow on the **LSB (SW2)** switch to 1.

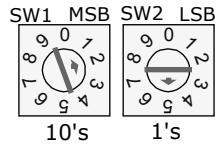

- 3 Turn on the RTU Open's power.



CAUTION The factory default setting is **00** and must be changed to successfully install your RTU Open.

To set the controller's communications protocol and baud rate

RTU Open's **SW3** DIP switches are used to set the controller's protocol and baud rate. The protocol and speed selection is determined by the network on which the controller will be installed. For Carrier BACnet implementations, select MS/TP @ 76.8 k as follows:

- 1 Power down the RTU Open. The controller reads the protocol and baud rate each time you apply power to it.
- 2 Set **SW3** DIP switches 1, 2, and 4 to **On** to configure the controller for BACnet MS/TP and 76.8 k baud.

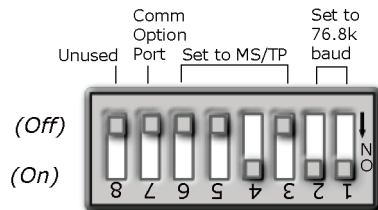

- 3 Power up the RTU Open.

NOTE Other protocols and baud rates are available. See the *RTU Open Integration Guide* for additional instructions.

Wiring for communications

The RTU Open communicates using BACnet on the following types of network segments:

- MS/TP communicating at 9600 bps, 19.2 kbps, 38.4 kbps, or 76.8 kbps
- ARC156 communicating at 156 kbps

NOTE For more networking details, see the *Open Controller Network Wiring Installation Guide*.

Wiring specifications for BACnet MS/TP and ARC156

Cable: 22 AWG or 24 AWG, low-capacitance, twisted, stranded, shielded copper wire

Maximum length: 2000 feet (610 meters)



WARNING Do not apply line voltage (mains voltage) to the controller's ports and terminals.

To wire the controller to the BACnet network

- 1 Pull the terminal connectors from the RTU Open's power terminals.
- 2 Check the communications wiring for shorts and grounds.
- 3 Connect the communications wiring to the Network Comm J19 port's screw terminals labeled **Net +**, **Net -**, and **Shield**.

NOTE Use the same polarity throughout the network segment.

- 4 Set the communication type and baud rate.

For...	Set DIP switches 1 and 2 to...	Set DIP switch 4 to...
MS/TP	The appropriate baud rate. See the MS/TP Baud diagram on the controller.	On
ARC156	N/A. Baud rate will be 156 kbps regardless of the DIP switch settings.	Off

NOTE Use the same baud rate for all controllers on the network segment.

- 5 Wire the controllers on a BACnet MS/TP or BACnet ARC156 network segment in a daisy-chain configuration.
- 6 If the RTU Open is at either end of a network segment, connect a BT485 to the RTU Open.
- 7 Insert the power screw terminal connector into the RTU Open's power terminals.
- 8 Verify communication with the network by viewing a Module Status report in the i-Vu® interface.

Wiring inputs and outputs

RTU Open Inputs and Outputs Table

Channel Number	Type	Signal	Function	Part Number	Wire and Terminal Numbers	Alternate Terminals
Input 1	AI	4-20 mA	CO2 OAQ Space Relative Humidity	33ZCT55C02 33ZCT56C02 33ZCSPTC02-01 33ZCSPTC02LCD-01 w/ 33ZCASPC02 33ZCSENSRH-02	J4 - 5 & 6	N/A
Input 2	AI	4-20 mA	CO2 OAQ Space Relative Humidity	33ZCT55C02 33ZCT56C02 33ZCSPTC02-01 33ZCSPTC02LCD-01 w/ 33ZCASPC02 33ZCSENSRH-02	J4 - 2 & 3	N/A
Input 3	BI	24 Vac	Compressor Safety **2 Fan Status Filter Status Remote Occupancy Door Contact	N/A CRSTATUS005A00 CRSTATUS005A00 Field-supplied Field-supplied	J1 - 2	J5 - 5 & 6 ***
Input 4	BI	24 Vac	Safety Chain *	N/A	J1 - 9	N/A
Input 5	BI	24 Vac	Fire Shutdown **1, 2 Fan Status Filter Status Remote Occupancy Door Contact	Field-supplied CRSTATUS005A00 CRSTATUS005A00 Field-supplied Field-supplied	J1 - 10	J5 - 3 & 4 ***
Input 6	AI	10K Thermistor	Supply Air Temperature	33ZCSENSAT 33ZCSENDAT	J2 - 1 & 2	N/A
Input 7	AI	10K Thermistor	Outside Air Temperature	33ZCSENSOAT	J2 - 3 & 4	N/A
Input 8	BI	24 Vac	Enthalpy ** Fan Status Filter Status Remote Occupancy Door Contact	33SENTHSW CRSTATUS005A00 CRSTATUS005A00 Field-supplied Field-supplied	J2 - 6 & 7	J5 - 1 & 2 ***
Input 9	BI	24 Vac	IGC Input**** Humidistat ** Fan Status Filter Status Remote Occupancy Door Contact	--HL--38MG-029 CRSTATUS005A00 CRSTATUS005A00 Field-supplied Field-supplied	J5 - 7 & 8	N/A
Input 10	AI	10K Thermistor	Space Temperature	33ZCT55SPT 33ZCT56SPT 33ZCT59SPT	J20 - 1 & 2	N/A
Input 11	AI	100K Thermistor	Space Temperature Setpoint Adjust	33ZCT56SPT 33ZCT59SPT	J20 - 3 & 4	N/A
Rnet	AI		ZS sensors SPT sensors Wireless Adapter for wireless sensors Equipment Touch	See <i>Wiring devices to the Rnet port.</i> (page 21)	J13 - 1, 2, 3, 4	N/A
AO - 1	AO	4-20 mA	Economizer	Actuator-Field-supplied	J2 - 5 & 4	N/A
AO - 2	AO	0-10 Vdc or 2-10 Vdc	Variable Frequency Drive	Field-supplied	J22 - 1 & 2	N/A

Channel Number	Type	Signal	Function	Part Number	Wire and Terminal Numbers	Alternate Terminals
BO - 1	BO	N/A - Relay	Fan (G)	N/A	J1 - 4	N/A
BO - 2	BO	N/A - Relay	Heat 2 (W2) Output	N/A	J1 - 5	N/A
BO - 3	BO	N/A - Relay	Heat 1 (W1) Output	N/A	J1 - 6	N/A
BO - 4	BO	N/A - Relay	Cool 2 (Y2) Output	N/A	J1 - 7	N/A
BO - 5	BO	N/A - Relay	Cool 1 (Y1) Output	N/A	J1 - 8	N/A
BO - 6	BO	N/A - Relay	Humidi-MiZer™	N/A	J11 - 7 & 8	N/A
BO - 7	BO	N/A - Relay	Reversing Valve / High Speed Fan / Y3	N/A	J11 - 5 & 6	N/A
BO - 8	BO	N/A - Relay	Power Exhaust	N/A	J11 - 2 & 3	N/A

Legend

AI - Analog Input **AO** - Analog Output

BI - Digital Input **BO** - Digital Output

* **Safety Chain Feedback** - 24 Vac required at this wire to provide **Run Enabled** status. Provide a jumper from **J1** - 1 to **J1** - 9 if no safeties are used. See *To wire inputs and outputs* (page 15) for additional information on the RTU Open wiring harness assembly terminations.

** Default input function

*** Parallel screw terminal at **J5** (**J5** - 1 = **J2** - 6, **J5** - 3 = **J1** - 10, **J5** - 5 = **J1** - 2) may be used in place of the associated flying leads at the harness (Part# OPN-RTUHRN). See *To wire inputs and outputs* (page 15) for additional information.

**** Binary Input 9: Integrated Gas Control reports status and if the flame is present.

1 N.C. contact must be used as a primary safety device for approved fire shutdown operation. N.O. contact for monitoring only.

2 If a function other the default is used, do NOT connect wires from J1-x.

Input wiring specifications

Input	Maximum length	Minimum gauge	Shielding
Thermistor	1000 feet (305 meters)	22 AWG	Unshielded
4-20 mA	3000 feet (914 meters)	22 AWG	Unshielded
Binary input	1000 feet (305 meters)	22 AWG	Unshielded
SPT (Rnet)	500 feet (152 meters)	See <i>Rnet wiring specifications</i> (page 22).	
ZS (Rnet)			
Wireless Adapter for Wireless sensors			

Inputs

These RTU Open inputs accept the following signal types:

These Inputs...	Support this signal type...	Description
1, 2	4-20 mA	The input resistance on the positive (+) terminal is 250 Ohms. The Aux Power Out terminal is capable of supplying 24 Vdc to a 4-20 mA transducer, but the total current demanded must not exceed 40 mA. If the voltage measured from the Aux Power Out terminal to Gnd is less than 18 Vdc, you need to use an external power supply.
3, 5, 8, 9	Binary (24 Vac)	24 Vac voltage, resulting in a 25 mA maximum sense current when the contacts are closed
6, 7, 10	Thermistor	10 kOhm at 77 °F (25 °C)
11	100k Potentiometer	Typically used for 33CZT56SPT Setpoint Offset Potentiometer

Binary outputs

The RTU Open has 8 binary outputs. You can connect each output to a maximum of 24 Vac/Vdc. Each output is a dry contact rated at 3 A, 24 V maximum, and is normally open.

To size output wiring, consider the following:

- Total loop distance from the power supply to the controller, and then to the controlled device
NOTE Include the total distance of actual wire. For 2-conductor wires, this is twice the cable length.
- Acceptable voltage drop in the wire from the controller to the controlled device
- Resistance (Ohms) of the chosen wire gauge
- Maximum current (Amps) the controlled device requires to operate

Analog outputs

The RTU Open has 2 analog outputs that support voltage or current devices.

AO-1 - 2-10 Vdc or 4-20 mA (Configure on jumper J3)

AO-2 - 0-10 Vdc or 2-10 Vdc

NOTE The controlled device must share the same ground as the controller. When used as a 4-20 mA output, the load must have an input impedance of 500 Ohms or less. If the output is used as a voltage type output, then the load impedance must be 10K ohms or greater.

To wire inputs and outputs

- 1 Turn **off** the RTU Open's power.
- 2 Connect the input wiring to the screw terminals on the RTU Open.
- 3 Turn **on** the RTU Open's power.
- 4 Set the appropriate jumpers on the RTU Open.

J3	AO - 1	0 - 10 Vdc/4-20 mA
W1	Battery Jumper	In (Do not remove)
W2	Format Jumper*	Out
W3	Input 11 mA Jumper	Out (mA not used on this channel)
W4	Input 11 Thermistor	In (default position)
W5	Input 10 mA Jumper	Out (mA not used on this channel)
W6	Input 10 Thermistor Jumper	<ul style="list-style-type: none"> • In (default position) Turn off the RTU Open's power. • Connect the input wiring to the screw terminals on the RTU Open. • Turn on the RTU Open's power. • Set the appropriate jumpers on the RTU Open.

*Formatting the controller may result in lost information and should only be done under the guidance of Carrier Control Systems Support.

Wiring Harness Assembly Terminations

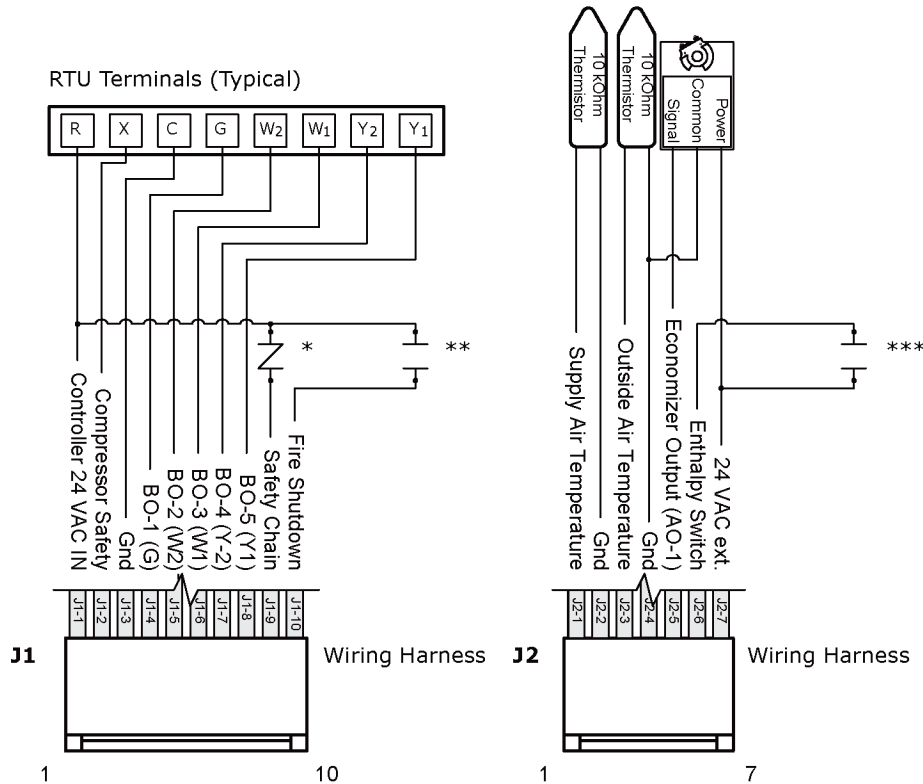

Optional

- * Safety chain devices, field-installed - normally closed. Apply 24 Vac to this terminal (jumper from **J1** - 1 to **J1** - 9) where no safety devices are installed.
- ** Fire shutdown device, field-installed, configurable as normally open or closed
- *** Enthalpy switch, field-installed - configurable as normally open or closed

J4 Inputs

- 1 Turn **off** the RTU Open's power.
- 2 Connect the input and output wiring to the screw terminals on the RTU Open.

NOTE When utilizing the controller's 24 Vdc auxiliary power out, the total current demand for these two input channels must not exceed 40 mA (or a maximum of 25 mA per channel).

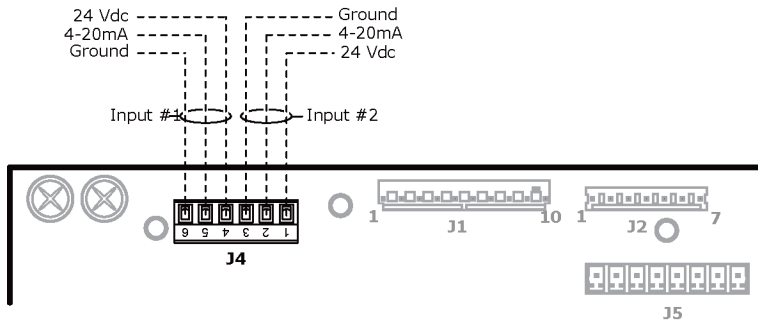

NOTE J4 Analog Inputs 1 and 2 may be set for the following device types:

- IAQ Sensor
- OAQ Sensor
- Space RH Sensor

J5 Inputs

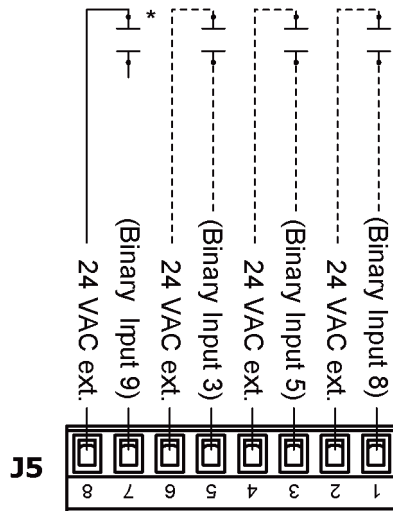

The terminals for Inputs 3, 5, and 8 are available for use in place of the flying wire leads at Molex connectors J1 and J2 identified below:

NOTE J5 binary inputs 3, 5, and 8 are the same input channels as:

- **J1** wire 2, **J5 - 5** Input - 3 (**Compressor Safety**)
- **J1** wire 10, **J5 - 3** Input - 5 (**Fire Shutdown**)
- **J2** wire 6, **J5 - 1** Input - 8 (**Enthalpy Switch**).

These terminals are available for use in place of the flying wire leads at Molex connectors **J1** and **J2**.

Binary inputs are configurable and may be used for the following functions:

Input	Default Input function	Additional functions
3	Compressor Safety	Fan Status Filter Status Remote Occupancy Door Contact
5	Fire Shutdown	Fan Status Filter Status Remote Occupancy Door Contact
8	Enthalpy Switch	Fan Status Filter Status Remote Occupancy Door Contact
9	HumidiStat*	ICG Input Fan Status Filter Status Remote Occupancy Door Contact

* If **Unit Type** is set to **LC Weather Expert™** and **Heat Type** is gas, Input 9 is automatically set to **ICG Input**.

J11 Outputs

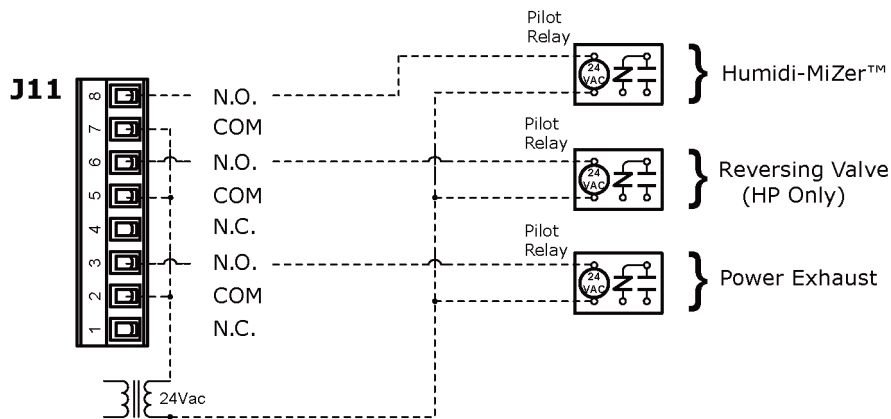

NOTE Output relay contacts rated at 3A, 24V maximum. Install pilot relays required by application.

J20 Inputs

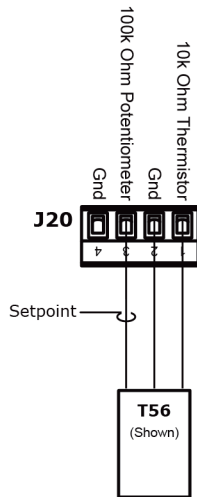

NOTE J20 Analog Inputs 10 and 11 are reserved for a 10k Ohm space temperature sensor with an optional 100k Ohm offset potentiometer used for setpoint adjustment.

Wiring sensors and switches to the controller

You may wire various sensors to the RTU Open's inputs. See the table below for details.

NOTE This document gives instructions for wiring the sensors to the RTU Open. For specific mounting and wiring instructions, see the *Carrier Sensors Installation Guide*.

All field control wiring that connects to the RTU Open must be routed through the raceway built into the corner post. The raceway provides the UL-required clearance between high-and low-voltage wiring.

- 1 Pass the control wires through the hole provided in the corner post.
- 2 Feed the wires through the raceway to the RTU Open.
- 3 Connect the wires to the removable Phoenix connectors.
- 4 Reconnect the connectors to the board (where removed).

NOTE For rooftop unit installation, see the base unit installation instructions.

WARNING Electrical Shock Hazard

Failure to follow this warning could cause personal injury, death, and/or equipment damage.

Disconnect all power to the unit before performing maintenance or service. Unit may automatically start if power is not disconnected.

Field-supplied sensor hardware

The RTU Open controller is configurable with the following field-supplied sensors:

Sensor	Part numbers	Notes
Space temperature sensor	SPS, SPPL, SPP, 33ZCT55SPT, 33ZCT56SPT, 33ZCT59SPT	
Space ZS sensors (page 21) <ul style="list-style-type: none"> • Temperature • Temperature and CO2 • Temperature and RH • Temperature and RH and CO2 	See the <i>ZS Sensors Installation Guide</i> .	
Carrier wireless sensors	See <i>Wireless Sensors Installation Guide</i> .	
Supply air temperature sensor (page 27)	33ZCSENSAT	Factory-installed
Duct air temperature sensor (page 28)	33ZCSENDAT	
Outdoor air temperature sensor (page 29)	33ZCSENOAT	Factory-supplied with Economizer
CO2 sensor (page 30)	33ZCSPTC02-01 33ZCSPTC02LCD-01 33ZCT55C02, 33ZCT56C02	Required only for demand control ventilation - a dedicated 24-Vac transformer is required
Outdoor air quality sensor (page 31)	33ZCTSENC02	Optional with demand control ventilation
Duct relative humidity sensor (page 32)	33ZCSENDRH-02	
Space relative humidity sensor (page 32)	33ZCSENSRH-02	
Humidistat (page 33)	-HL-38MG-029	
CO2 aspirator box (page 30)	C33ZCCASPC02	Required for CO2 return duct/outside air applications
Outdoor air enthalpy switch (page 34)	33CSENTHSW	
Return air enthalpy sensor (page 34)	33CSENSEN	Optional with 33CSENTHSW
Filter status switch (page 37)	CRSTATUS005A00	
Fan status switch (page 37)	CRSTATUS005A00 or field-supplied	

For specific details about sensors other than ZS or wireless, see the *Carrier Sensors Installation Guide*.

Wiring devices to the RTU Open's Rnet port

The Rnet communicates at a rate of 115 kbps.

Wireless sensors

You can wire a Wireless Adapter to RTU Open's **Rnet** port. The Wireless Adapter communicates with up to 15 wireless sensors. When using wireless sensors, the Rnet can have:

- Up to 15 wireless and ZS sensors (any combination)
- One Wireless Adapter
- One Equipment Touch

ZS sensors

You can wire up to 5 ZS sensors to the RTU Open's **Rnet** port. ZS sensors can share the Rnet with the devices listed above.

NOTES

- A control program can use no more than 5 ZS sensors.
- The ZS CO2 model uses 190 mA during sample period. Use auxiliary 12 Vdc, unless it is the only device on the Rnet port.

SPT sensors

You can wire SPT sensors to the RTU Open's **Rnet** port. An Rnet can consist of any of the following combinations of devices wired in a daisy-chain or star configuration:

- 1 SPT Plus or SPT Pro
- 1–4 SPT Standards
- 1–4 SPT Standards, and 1 SPT Plus or SPT Pro

NOTE SPT sensors cannot share the Rnet with other devices.

Equipment Touch

You can wire an Equipment Touch to the RTU Open's Rnet port to view or change the controller's property values, schedule equipment, view trends and alarms, and more, without having to access the system's server. The Rnet can have one Equipment Touch, one Wireless Adapter, and up to 5 ZS sensors. SPT sensors cannot share the Rnet with an Equipment Touch.



CAUTIONS

- Equipment Touch requires 24 Vac and cannot be powered by Rnet's 12 Vdc. For more details, see the *Equipment Touch Installation and Setup Guide*.

If you exceed 200 mA, then one or more devices need an auxiliary 12 Vdc power supply.

Rnet wiring specifications

NOTE Use the specified type of wire and cable for maximum signal integrity.

Description	4 conductor, shielded or unshielded, CMP, plenum rated cable
Conductor	22 AWG (7x0096) bare copper if Rnet has only sensors
Maximum length	500 feet (152 meters)
Insulation	Low-smoke PVC (or equivalent)
Color Code	Black, white, green, red
Shielding	If shielded, Aluminum/Mylar shield (100% coverage) with TC drain wire, terminated at controller
UL temperature rating	32–167 °F (0–75 °C)
Voltage	300 Vac, power limited
Listing	UL: NEC CL2P, or better

ZS Sensor overview

ZS Sensors are thermistor-based temperature sensors that may optionally sense humidity, CO₂, or VOC. ZS Sensors are wired to the Rnet port on i-Vu® Open controllers.

You can use the following ZS sensors:

- ZS Standard
- ZS Plus
- ZS Pro

NOTES

- A control program can use no more than 5 ZS Sensors.
- The ZS CO₂ model uses 190 mA during sample period. Use auxiliary 12 Vdc, unless it is the only device on the Rnet port.

For basic user instructions, see the *ZS Sensor User Guide*. For detailed installation instructions, see the *ZS Sensors Installation Guide*.

SPT sensor overview

The RTU Open is connected to a wall-mounted space temperature sensor to monitor room temperature. Wire SPT sensors to the RTU Open's **Rnet** port.

The RTU Open supports the following:

- SPT Standard
- SPT Plus
- SPT Pro

For basic user instructions, see the *SPT Sensors Owner Guide*. For more detailed instructions, see the *Carrier Sensors Installation Guide*.

NOTE If the Rnet has multiple SPT Standard sensors, you must give each a unique address on the Rnet.

To wire the ZS or SPT sensor to the RTU Open

- 1 Partially cut, then bend and pull off the outer jacket of the Rnet cable(s). Do not nick the inner insulation. Strip about .25 inch (.6 cm) of the inner insulation from each wire.

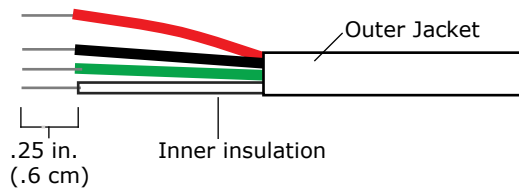

- 2 Wire each terminal on the sensor to the same terminal on the controller. See diagram below.

NOTE Carrier recommends that you use the following Rnet wiring scheme:

Connect this wire...	To this terminal...
Red	+12V
Black	Rnet-
White	Rnet+
Green	Gnd

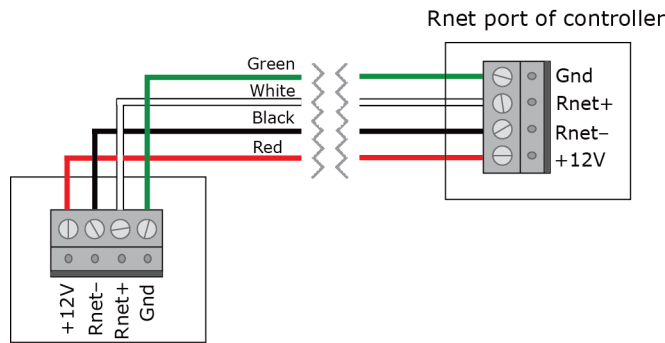

Wireless sensor overview

The Carrier wireless sensors, designed for zone control, are low-power wireless devices that use light-harvesting through solar panels as their primary power source. The wireless line of sensors includes the models shown in the list below. All are available in 868, 902, and 928 MHz radio frequency. The sensors are thermistor-based temperature sensors that may optionally sense humidity.

Wireless sensors communicate through a Wireless Adapter, which is wired to the Rnet port of the controller.

REQUIREMENTS

- A v6.5 or later i-Vu® system
- v6-xx-xxx or later controller drivers

The following is a list of all available wireless devices:

- Standard
- Plus
- Pro-F
- Motion/Lux Sensor
- Window/Door Sensor
- Adapter

To configure the control program for the desired user interaction with the sensor, see the *Wireless Sensors Application Guide*. For detailed instructions, see the *Wireless Sensors Installation Guide*.

To install the Wireless Adapter for wireless sensors

WARNING Do not apply line voltage (mains voltage) to the Wireless Adapter.

To wire, power, and mount the Wireless Adapter

NOTES

- The Wireless Adapter requires a 24 Vac or 24 Vdc power supply. It is not powered by the Rnet.
- If the Wireless Adapter will be:
 - Daisy-chained on the Rnet with ZS sensors or an Equipment Touch, use the standard 4-conductor Rnet wiring.
 - The only device on the Rnet, you can use a 3-conductor cable instead of the standard 4-conductor Rnet cable.

- 1 Turn off the power to the controller that the Wireless Adapter will be wired to.
- 2 Partially cut, then bend and pull off the outer jacket of the Rnet cable(s). Do not nick the inner insulation.

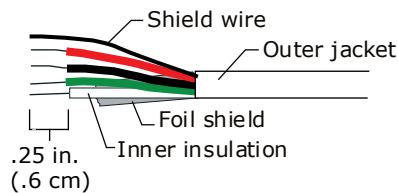

- 3 Strip about .25 inch (.6 cm) of the inner insulation from each wire.
- 4 Wire the **Rnet +**, **Rnet -**, and **Gnd** terminals on the controller's **Rnet** port to the terminals of the same name on the Wireless Adapter's Rnet connector.

NOTE If using shielded wire, connect the shield wire and the ground wire to the **Gnd** terminal.



- 5 Wire the 24 Vac external power supply to the Wireless Adapter's power connector.
- 6 Mount the Wireless Adapter by inserting 2 screws through the mounting tabs on each end of the Wireless Adapter.
- 7 Apply power to the external power supply.
- 8 Verify that the LED on top of the Wireless Adapter is blinking. See "LED" below.
- 9 Turn on the controller's power.

LED

The blue LED on the top of the Wireless Adapter indicates the following:

If the LED is...	Then the device...
Off	Is not powered or there is a problem.
Blinking	Is working properly.
Steadily on	Has a problem. Do one of the following: <ul style="list-style-type: none"> • Cycle power to the device. • Insert a small screwdriver or paper clip into the hole next to the LED to reboot the device.

To wire an Equipment Touch to the RTU Open

NOTE The Equipment Touch requires a 24 Vac power supply. It is not powered by the Rnet.



CAUTION Carrier controllers can share a power supply as long as you:

- Maintain the same polarity.
- Use the power supply only for Carrier controllers.

If the Equipment Touch will be:

- Daisy-chained on the Rnet with ZS sensors or a Wireless Adapter, use the standard 4-conductor Rnet wiring and follow the wiring instructions *To wire a ZS or SPT sensor to the RTU Open* (page 23).
- The only device on the Rnet, you can use a 2-conductor cable instead of the standard 4-conductor Rnet cable and follow the instructions below.

For complete Equipment Touch installation instructions including wiring diagrams, see the *Equipment Touch Installation and Setup Guide*.

- 1 Turn **off** the RTU Open's power.
- 2 Partially cut, then bend and pull off the outer jacket of the cable. Do not nick the inner insulation.

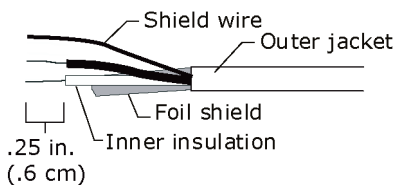

- 3 Strip about .25 inch (.6 cm) of the inner insulation from each wire.

- 4 Wire the RTU Open's **Rnet+** and **Rnet-** terminals to the terminals of the same name on the Equipment Touch's connector.

NOTE If using shielded wire, connect the shield wire and the ground wire to the **Gnd** terminal.

- 5 Turn **on** the RTU Open's power.
- 6 Turn on the Equipment Touch.

Wiring a Supply Air Temperature sensor

Part #33ZCSENSAT

The RTU Open requires a temperature sensor installed in the supply air stream. The Supply Air Temperature (SAT) sensor is used to properly control the SAT to the maximum and minimum supply air temperature limits, provide integrated economizer operation, and control the supply fan VFD output, if **Fan Control** is set to **Variable Speed**.

Wiring specifications

Cable from sensor to controller:	If <100 ft (30.5 meters)	22 AWG, unshielded
	If >100 ft (30.5 meters)	22 AWG, shielded
Maximum length:	500 feet (152 meters)	

To wire the SAT sensor to the controller

- 1 Connect the wiring harness (OPN-RTUHRN). For details, see *To wire inputs and outputs* (page 15).
- 2 Wire the sensor to the wiring harness. See diagram below.
- 3 Connect to **J2** wires 1 and 2.
- 4 Verify your sensor readings.

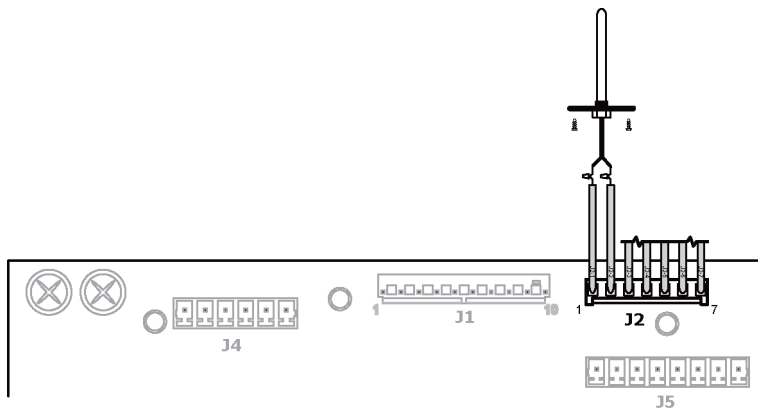

Wiring a duct air temperature sensor

Part #33ZCSENDAT

The RTU Open requires a temperature sensor installed in the supply air stream. The Duct Temperature (DAT) sensor is generally used when the rooftop unit is NOT equipped with electric heating.

Wiring specifications

Cable from sensor to controller:	If <100 ft (30.5 meters)	22 AWG, unshielded
	If >100 ft (30.5 meters)	22 AWG, shielded
Maximum length:	500 feet (152 meters)	

To wire a DAT sensor to the controller

- 1 Connect the wiring harness (Part#OPN-RTUHRN). For details, see *To wire inputs and outputs* (page 15).
- 2 Wire the sensor to the wiring harness. See diagram below.
- 3 Connect to **J2** wires 1 and 2.
- 4 Verify your sensor readings.
- 5 Drill .25" diameter hole. Pass sensor leads through bushing and insert assembly into hole. Secure leads to ductwork with aluminum tape.

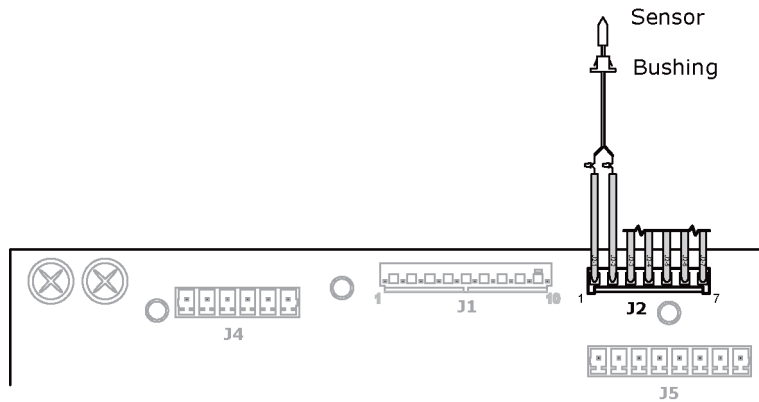

NOTE Sensor termination requires installation of RTU Open wiring harness assembly (Part #OPN-RTUHRN).

Wiring an outdoor air temperature sensor

Part #33ZCSENOAT

Outdoor Air Temperature (OAT) is required to use all of the RTU Open's features. OAT may be provided by a local sensor (shown below) or a linked sensor in another controller. See *Single Point Linkage* (page 90).

Wiring specifications

Cable from sensor to controller:	If <100 ft (30.5 meters)	22 AWG, unshielded
	If >100 ft (30.5 meters)	22 AWG, shielded
Maximum length:	500 feet (152 meters)	

To wire an OAT sensor to the controller

- 1 Connect the wiring harness (Part#OPN-RTUHRN). For details, see *To wire inputs and outputs* (page 15).
- 2 Wire the sensor to the wiring harness. See diagram below.
- 3 Connect to **J2** wires 3 and 4.
- 4 Verify your sensor readings.

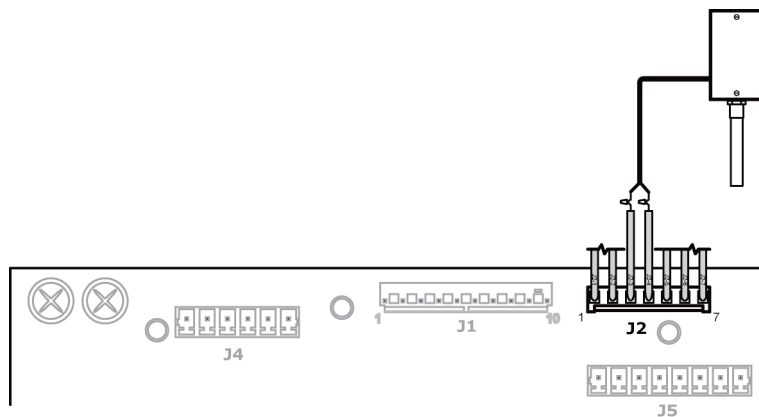

Wiring a CO2 sensor

Part #33ZCSPTCO2LCD-01 (Display model)
 Part #33ZCSPTCO2-01 (No display)

Part #33ZCT55CO2 (No display)
 Part #33ZCT56CO2 (No display)

A CO₂ sensor monitors carbon dioxide levels. As CO₂ levels increase, the RTU Open adjusts the outside air dampers to increase ventilation and improve indoor air quality. A CO₂ sensor can be wall-mounted or mounted in a return air duct. Duct installation requires an Aspirator Box Accessory (Part #33ZCASPCO2).

The sensor has a range of 0–2000 ppm and a linear 4-20 mA output. The CO₂ sensor’s power requirements exceed what is available at **J4** - 1 and 4. Provide a dedicated 24Vac transformer or DC power supply.

Wiring specifications

Cable from sensor to controller:	If <100 ft (30.5 meters)	22 AWG, unshielded
	If >100 ft (30.5 meters)	22 AWG, shielded
Maximum length:	500 feet (152 meters)	

To wire a separate dedicated CO2 sensor to the controller

- 1 Wire the sensor to the controller. See appropriate diagram below.
- 2 Install a field-supplied dedicated 24 Vac transformer or DC power supply.
- 3 Wire the sensor to the controller.

Wiring diagram for #33ZCSPTCO2:

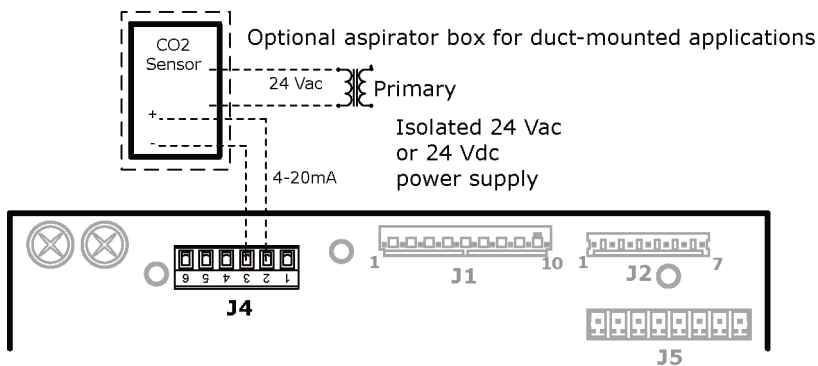

Wiring diagram for #33ZCT55/56CO2:

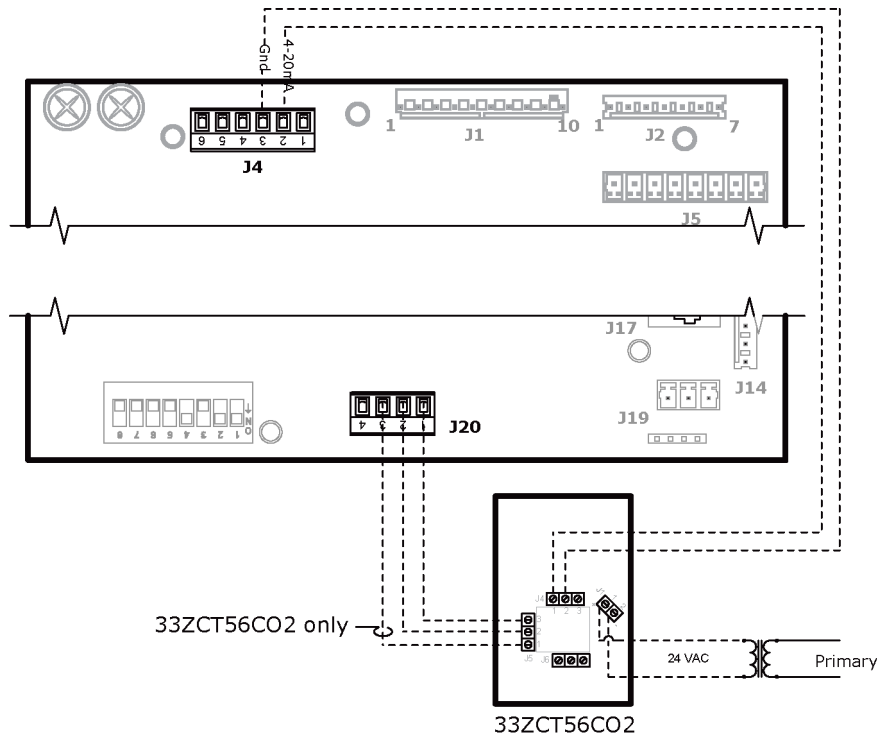

Wiring an outdoor air quality sensor

Part #33ZCSPTCO2LCD-01 (Display model)
 Part #33ZCSPTCO2-01 (No display)

An outdoor air quality (OAQ) sensor monitors outside air carbon dioxide levels. The RTU Open uses this information, in conjunction with a CO₂ sensor, to adjust the outside air dampers to provide proper ventilation. An OAQ sensor is typically duct-mounted in the outside air stream. Duct installation requires an Aspirator Box Accessory (Part #33ZCASPCO2).

The sensor has a range of 0–2000 ppm and a linear 4-20 mA output. The CO₂ sensor’s power requirements exceed what is available at **J4** - 1 and 4. Provide a dedicated 24 Vac transformer or DC power supply.

Wiring specifications

Cable from sensor to controller:	If <100 ft (30.5 meters)	22 AWG, unshielded
	If >100 ft (30.5 meters)	22 AWG, shielded
Maximum length:	500 feet (152 meters)	

To wire the OAQ sensor to the controller

- 1 Wire the sensor to the controller. See appropriate diagram below.
- 2 Install a field-supplied dedicated 24 Vac transformer or DC power supply.
- 3 Apply power and verify sensor readings.

Wiring diagram for #33ZCSPTC02-01:

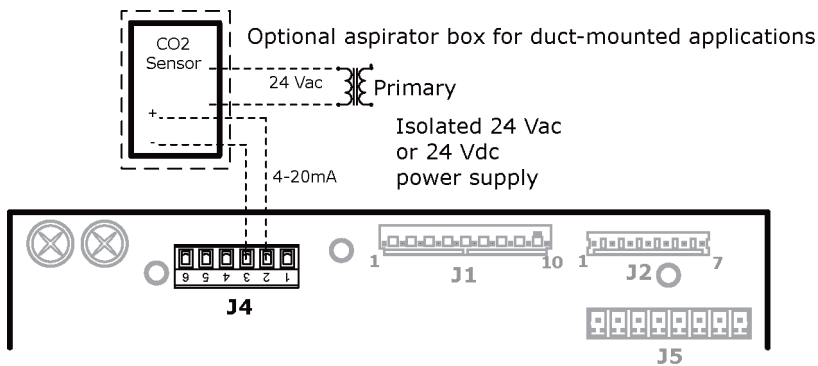

NOTE Sensor may be terminated at Input 1 or 2.

Wiring a relative humidity sensor

Wall and duct sensor - Part #33ZCSENSRH-02 and 33ZCSENDRH-02

The Relative Humidity (RH) sensor may be used for zone humidity control (dehumidification) when applied to a Carrier rooftop unit equipped with the Humidi-MiZer™ option. On units not equipped for dehumidification, the sensor monitors humidity, but provides no control.

NOTE You cannot use a relative humidity sensor when using both a CO₂ and OAQ sensor on the controller.

Wiring specifications

Cable from sensor to controller:	If <100 ft (30.5 meters)	22 AWG, unshielded
	If >100 ft (30.5 meters)	22 AWG, shielded
Maximum length:	500 feet (152 meters)	

To wire a separate dedicated RH sensor to the controller

- 1 Strip the outer jacket from the cable for at least 4 inches (10.2 cm). Strip .25 inch (.6 cm) of insulation from each wire.
- 2 Wire the sensor to the controller. See diagram below.
- 3 Apply power and verify sensor readings.

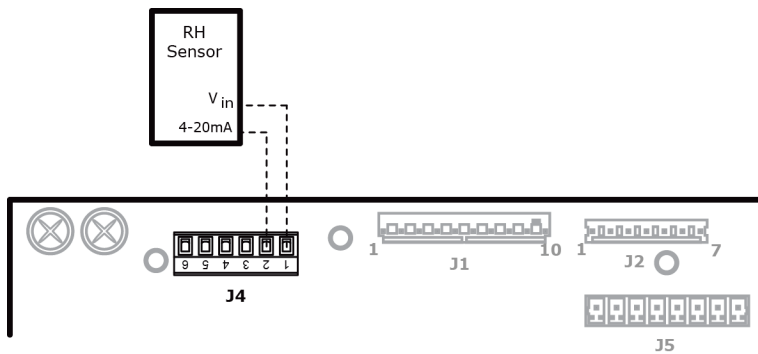

NOTE Sensor may be terminated at Input 1 or 2.

Wiring a Humidistat

Locally Purchased

A humidistat may be used for zone humidity control (dehumidification) when applied to a Carrier rooftop unit equipped with the Humidi-MiZer™ option. On units not equipped for dehumidification, the humidistat will indicate a high humidity condition only.

NOTE The humidistat is NOT an option for LC WeatherExpert™ units with gas heat. You must use the RH sensor for humidity control.

Wiring specifications

Cable from sensor to controller:	If <100 ft (30.5 meters)	22 AWG, unshielded
	If >100 ft (30.5 meters)	22 AWG, shielded
Maximum length:	500 feet (152 meters)	

To wire a humidistat to the controller

- 1 Strip the outer jacket from the cable for at least 4 inches (10.2 cm). Strip .25 inch (.6 cm) of insulation from each wire
- 2 Wire the humidistat to the controller. See diagram below.
- 3 Apply power and verify sensor readings.

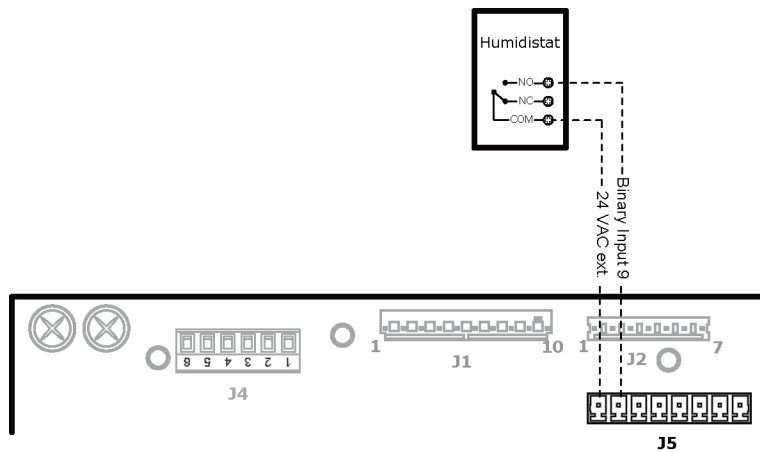

NOTE Humidistat may be return duct or space mounted.

Wiring an enthalpy switch

Outdoor Air - Part #33CSENTHSW

Return air - Part #33CSENSEN

The 33CSENTHSW is an outdoor air enthalpy switch/receiver. This control determines the suitability of the outdoor air as a cooling source, based on the heat content of the air. Differential enthalpy control requires installing a 33CSENSEN enthalpy sensor in the rooftop unit's return air duct.

Wiring specifications

Cable from sensor to controller:	If <100 ft (30.5 meters)	22 AWG, unshielded
	If >100 ft (30.5 meters)	22 AWG, shielded
Maximum length:	500 feet (152 meters)	

To wire an enthalpy switch (outdoor air) to the controller

An enthalpy switch is typically mounted in the outdoor air inlet.

Wiring diagram for a field-installed enthalpy switch:

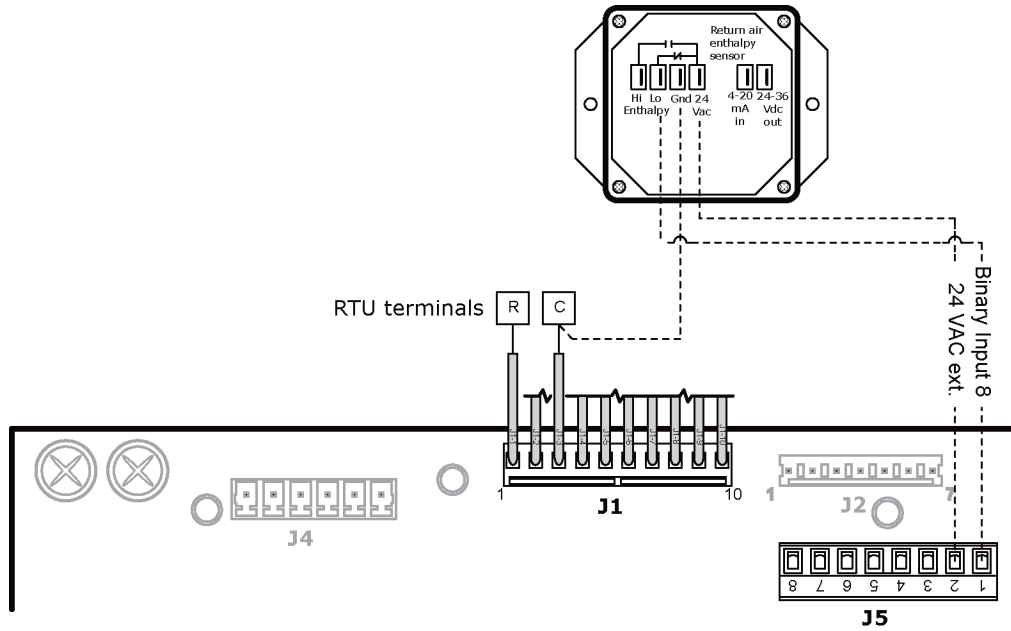

NOTES

- Factory-installed enthalpy switches terminate at **J2** wires 6 (switch input) and 7 (24 Vac).
- Input channel must be configured for the enthalpy contact (N.O. or N.C.) that you use.

Wiring diagram for factory-installed enthalpy switch:

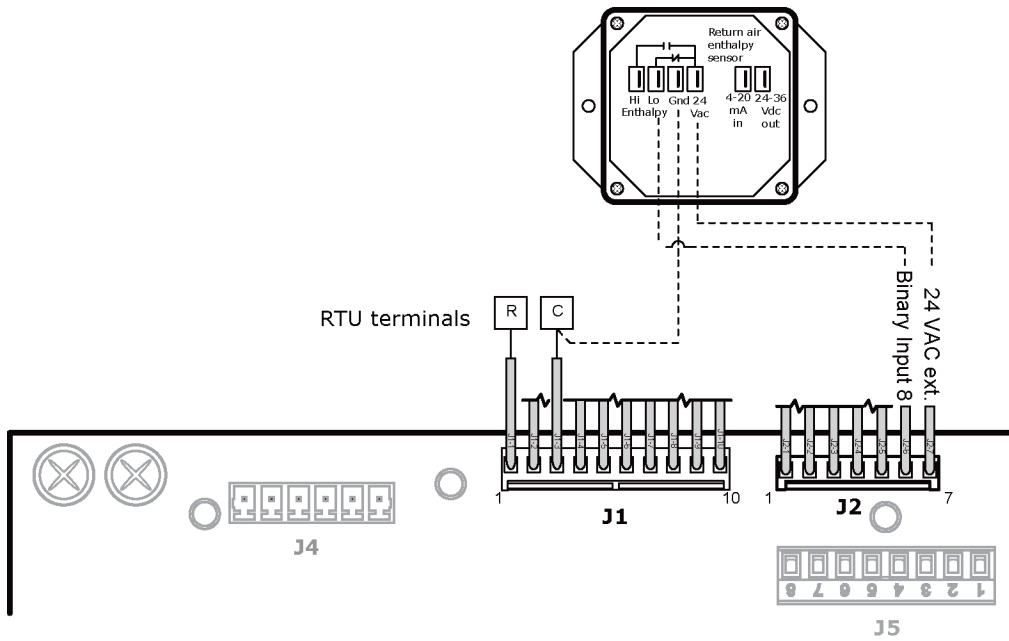

NOTE Factory-installed enthalpy switches terminate at **J2** wires 6 (switch input) and 7 (24 Vac).

To wire an enthalpy switch (differential) to the controller

Wiring diagram for optional enthalpy sensor mounted in the return air for differential enthalpy:

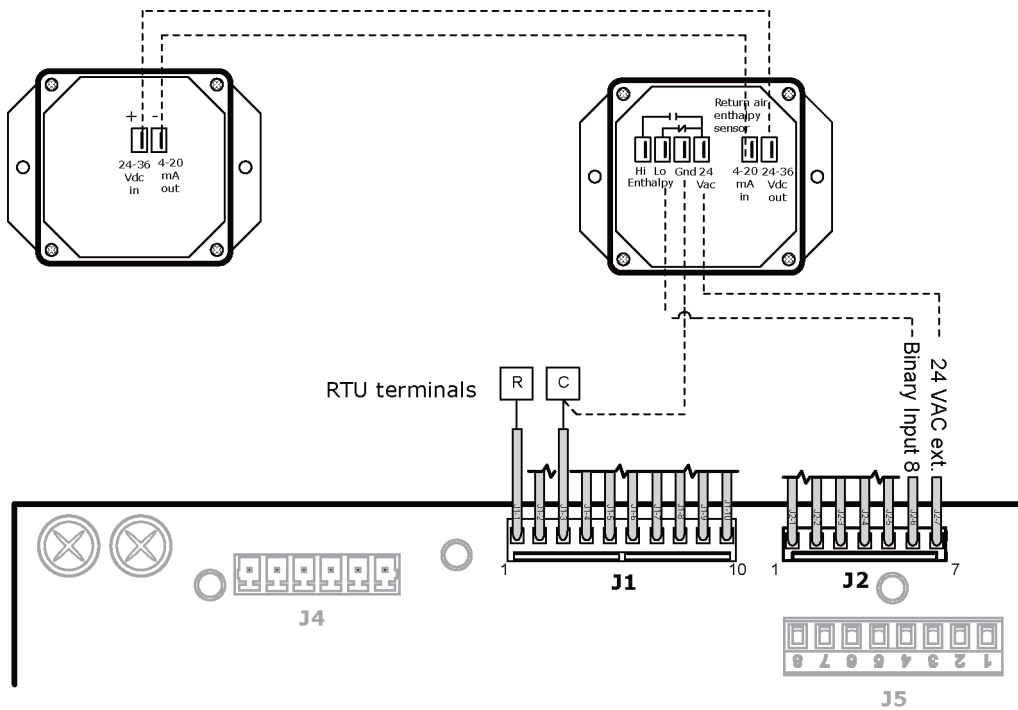

Wiring a status switch

Filter - Part #CRSTATUS005A00 or field-supplied

Fan status - Part #CRSTATUS005A00 or field-supplied

Filter and/or fan status switches may be installed to provide a **Dirty Filter** indication or **Fan Running** status.

Wiring specifications

Cable from sensor to controller:	If <100 ft (30.5 meters)	22 AWG, unshielded
	If >100 ft (30.5 meters)	22 AWG, shielded
Maximum length:	500 feet (152 meters)	

To wire a status switch to the controller

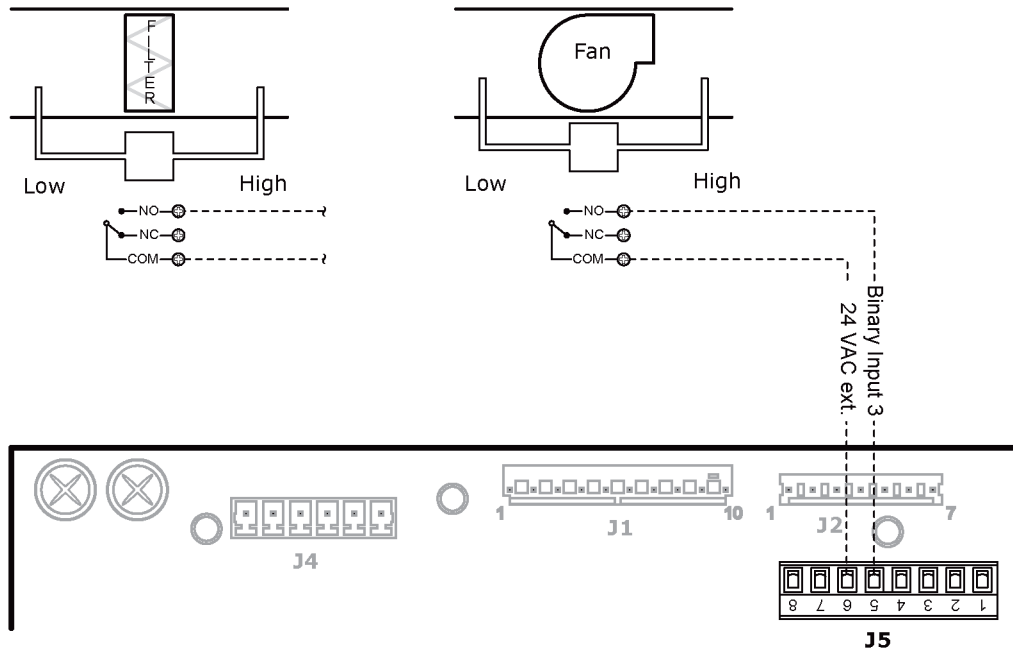

NOTES

- Binary inputs 3, 5, 8, and 9 are configurable and may be used for **Fan Status**, **Filter Status**, **Remote Occupancy**, or **Door Contacts**, if they have not already been used for their default functions.
- Follow device manufacturer's installation and operating instructions.

Wiring a compressor safety

This is typically provided by the manufacturer with the rooftop equipment. A compressor safety status may be monitored if available.

Wiring specifications

Cable from sensor to controller:	If <100 ft (30.5 meters)	22 AWG, unshielded
	If >100 ft (30.5 meters)	22 AWG, shielded
Maximum length:	500 feet (152 meters)	

To wire a compressor safety input to the controller

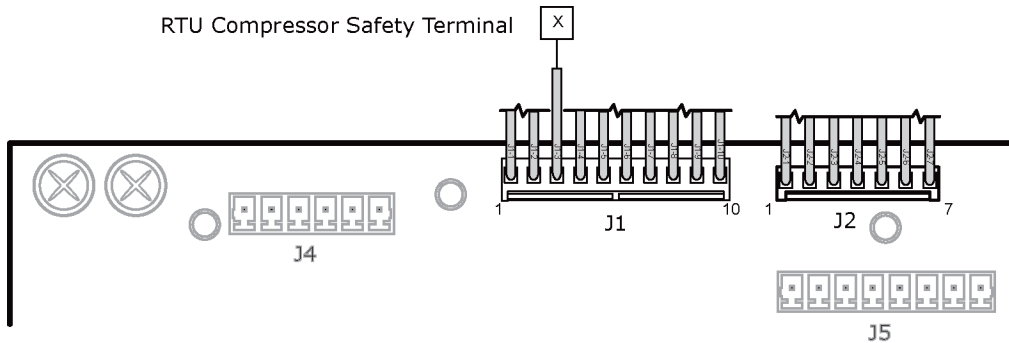

NOTES

- An isolation relay may be required if the RTU Open is powered separately from the equipment's control power circuit.
- Follow device manufacturer's installation and operating instructions.

Wiring an occupancy switch or door contact

Occupancy switch - field-supplied

Door contact - field-supplied

Occupancy or door contact switches may be installed to provide an alternate means of occupancy determination or heating and cooling lockout. See *Sequence of Operation* (page 44) for additional details.

Wiring specifications

Cable from sensor to controller:	If <100 ft (30.5 meters)	22 AWG, unshielded
	If >100 ft (30.5 meters)	22 AWG, shielded
Maximum length:	500 feet (152 meters)	

To wire an occupancy switch or door contact

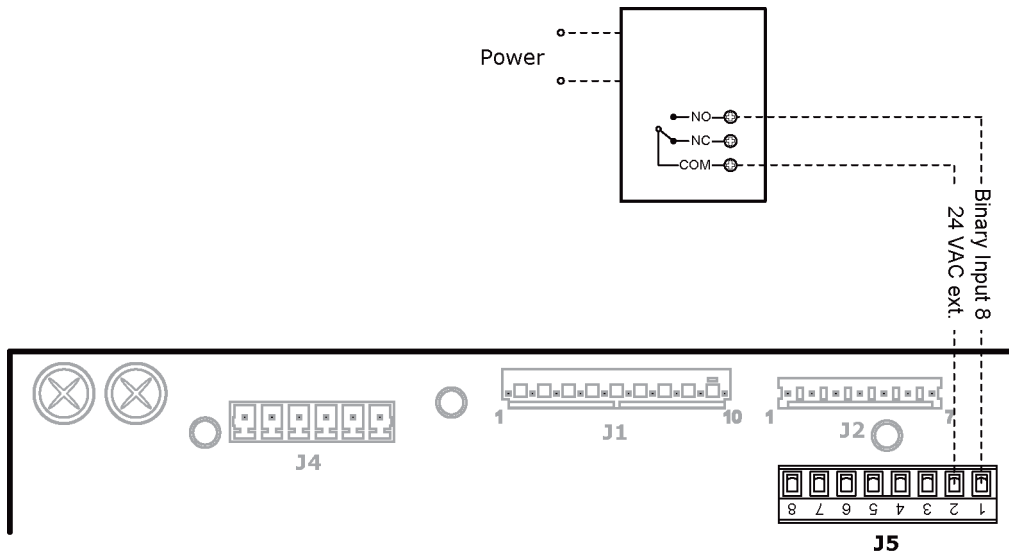

NOTES

- Binary Inputs 3, 5, 8, and 9 are configurable and may be used for **Fan Status, Filter Status, Remote Occupancy, or Door Contacts** - provided they have not been used for their default functions.
- Follow device manufacturer's installation and operating instructions.

Start-up

Use one of the following interfaces to start up, access information, read sensor values, and test the controller.

This interface...	Provides a...
Field Assistant application - Runs on a laptop that connects to controller's Local Access port ¹	Temporary interface
Equipment Touch device - Connects to controller's Rnet port ²	Temporary or permanent interface
i-Vu® application Available for BACnet systems only	Permanent interface
System Touch device Available only for BACnet MS/TP systems. Wire to a BACnet MS/TP network connector and a 24 Vac power supply ³	Temporary or permanent interface

¹ Requires a USB Link (Part #USB-L).

² See the *Equipment Touch Installation and Setup Guide* for detailed instructions.

³ See the *System Touch Installation and Setup Guide* for detailed instructions.



CAUTION If multiple controllers share power but polarity was not maintained when they were wired, the difference between the controller's ground and the computer's AC power ground could damage the USB Link and the controller. If you are not sure of the wiring polarity, use a USB isolator between the computer and the USB Link. Purchase a USB isolator online from a third-party manufacturer.

Service Test

Navigation: i-Vu / Field Assistant: **Properties > Equipment > Configuration > Service Configuration > Service Test**

Service Test can be used to verify proper operation of compressors, heating stages, indoor fan, power exhaust fans, economizer, and dehumidification. It is highly recommended to use **Service Test** at initial system start-up and during troubleshooting. See *Appendix A: Points/Properties* (page 61) for more information.

Service Test differs from normal operation as follows:

- Outdoor air temperature limits for cooling circuits, economizer, and heating are ignored.
- Normal compressor time guards and other staging delays are ignored.
- Alarm statuses (except **Fire** and **Safety Chain**) are ignored, but all alarms and alerts are still broadcast on the network, if applicable.

Service Test can be turned on or off from a Field Assistant, or the i-Vu® interface. Select **Default Value** of **Enable** to turn on and **Disable** to turn off.

NOTES

- **Service Test** allows testing of each controller output.
- **Binary Service Test** functions are on when the **Default Value** is set to **Enable** and off when set to **Disable**.
- The output of the **Analog Service Test** is controlled by the percentage (0-100%) entered into the **Default Value**.
- We recommend you return every individual **Service Test** variable to **Disable** or **0.00** after testing each function (unless that test variable must be active to test a subsequent function, as in **Compressor 2 Test**).
- All outputs return to normal operation when **Service Test** is set to **Disable**.

Service Test functions

- Use **Fan Test** to activate and deactivate the **Supply Fan** (BO - 1) output. Note that this output may enable simultaneously with other **Service Test** modes even with its **Default Value** set to **Disable**.
- Use **High Speed Fan Test** to activate and deactivate the **High Speed Fan Relay** (BO - 7) output. Note that this output is only applicable if **Fan Control** is set to **Two Speed** and **Unit Type** is NOT equal to **HP O/B Ctrl**.
- Use **Compressor 1 Test** to activate and deactivate the Compressor 1 (BO - 5) output. The **Supply Fan** output will be activated and deactivated in conjunction with this output.
- Use **Compressor 2 Test** to activate and deactivate the Compressor 2 (BO - 4) output. Always test the Compressor 1 output first. For all units except the LC WeatherExpert™, **Compressor 1 Test** output must be set to **Enable** for **Compressor 2 Test** to function.
- Use the **Reversing Valve Test** to activate and deactivate the reversing valve (BO - 7) output. Applicable to Unit Type **HP O/B Ctrl** only.
- Use the **Dehumidification Test** to activate and deactivate the Humidi-MiZer™ (BO - 6) output. The Supply Fan output will be activated and deactivated in conjunction with the Dehumidification Test output.
- Use **Heat 1Test** to activate and deactivate the Heat 1 (BO - 3) output. The Supply Fan output is activated and deactivated in conjunction with the **Heat 1Test** output.
- Use **Heat 2Test** to activate and deactivate the Heat 2 (BO - 2) output. The Supply Fan output is activated and deactivated in conjunction with the **Heat 2Test** output.
- Use **Power Exhaust Test** to activate and deactivate the power exhaust (BO - 8) output.
- Use **Economizer Test** to set the (AO - 1) economizer output to any value from 0 to 100% of configured output (2-10 Vdc or 0-10 Vdc).
- **VFD Speed Test** is used to set the (AO - 2) **VFD Speed Control** output to any value from 0 to 100% of configured output (2-10 Vdc or 4-20 mA). Note that this output is only applicable if **Fan Control** is set to **Variable Speed**.
- **Analog Output 2 Test** (AO - 2) is currently unused and does not require testing.
- Service Test mode does not timeout. Return all test variables to **Disable** or **0.00**. Set **Service Test** to **Disable** or cycle power to the RTU Open to return to normal operation.
- Service Test is not available on the Equipment Touch. Use the i-Vu® application or Field Assistant.

Configuring the RTU Open's properties

To start up the RTU Open, you must configure certain points and properties. Appendix A is a complete list of all the points and properties, with descriptions, defaults, and ranges. These properties affect the unit operation and/or control. Review and understand the meaning and purpose of each property before changing it.

- *Unit Configuration properties* (page 62)
- *Setpoint Configuration properties* (page 69)
- *Service Configuration properties* (page 77)
- *Linkage properties* (page 87)
- *Equipment Touch Startup Wizard* (page 94)

See *Appendix A* (page 92) for a complete list of the controller's points/properties.

NOTE Engineering units shown in this document in the defaults and ranges are strictly for reference. You must enter an integer only.

Sequence of Operation

The RTU Open supports various types of constant volume air source configurations:

- Standard heat/cool unit types with up to 2-stages of mechanical cooling and gas or electric heating
- Heat pump units utilizing a reversing valve output for heating and cooling control
- Heat pump unit (Carrier) with an OEM defrost control board
- Economizer, CO2, Demand Limiting, and RH control strategies are available for appropriately equipped units
- LC WeatherExpert™ unit with 3-stage compressor control and variable speed supply fan control.

The RTU Open may operate as part of a VVT system using Airside Linkage or as a stand-alone controller.

Occupancy

The RTU Open's operation depends upon its occupancy state (**Occupied/Unoccupied**). The RTU Open operates continuously in the **Occupied** mode until you configure an occupancy schedule.

An occupancy schedule may be:

- A local schedule configured in the controller using an Equipment Touch or Field Assistant
- A BACnet schedule configured in the i-Vu® application, networked through an i-Vu® Open Router
- A BACnet or local schedule configured for subordinate VVT Zones, networked through an i-Vu® Open Router(s) and employing Linkage

To set up occupancy schedules, see the documentation for your user interface.

NOTE A BACnet schedule, downloaded from the i-Vu® application will overwrite a local schedule that was set up with an Equipment Touch or Field Assistant.

Occupancy Source - the following settings determine occupancy.

Options:

- **Always Occupied** - (default) Controller operates continuously, regardless of any configured schedule
- **BACnet Schedule** - Uses a local BACnet occupancy schedule configured within the controller
- **BAS On/Off** - Occupancy is set over the network by another device or a third party BAS. Refer to the *RTU Open Integration Guide* for additional instructions in communication protocols.
- **Remote Occ Input** - Controller monitors an input contact connected to one of the available binary inputs configured to receive it. You must set **Unit Configuration > Occupancy Source** to **Remote Occ Input** and one **Input Switch Configuration** to **Remote Occupancy**.

Supply fan

The RTU Open supply fan may be configured for 1 of 3 **Fan Control modes**:

- **Single** - The fan operates at one speed only and provides on/off operation
- **Two Speed** - The fan operates at 1 of 2 speeds depending on the mode of operation and load conditions. During fan only or single stage cooling, the fan operates at low speed. During heating, second stage cooling, dehumidification, or if maximum economizer operation is required, the fan operates at high speed.
- **Variable Speed** - The fan operates at a variable speed to meet the load conditions and SAT safety requirements to provide maximum energy savings by minimizing fan horsepower consumption. Fan speed is NOT controlled by static pressure.

The RTU Open supply fan may be configured for 1 of 3 **Fan Modes**:

- **Auto** - The fan cycles on/off in conjunction with heating or cooling
- **Continuous** - The fan runs continuously during occupancy and intermittently during unoccupied periods with heating or cooling
- **Always On** - The fan runs continuously regardless of occupancy or calls for heating and cooling

Occupancy can be determined by Linkage, BACnet schedules, BAS schedules, or in response to a remote occupancy switch.

A **Fan Off Delay** allows the supply fan to continue operating after heating or cooling stops.

If the following alarms are active, the fan turns off immediately, regardless of the occupancy state or demand:

- **Fire Shutdown**
- **Safety chain**
- **Supply Air Temp Sensor** alarm
- **Space Temp Sensor** alarm

The RTU Open does not include smoke-control functions such as smoke-purge, zone-pressurization, or smoke-ventilation.

The RTU Open may be configured to accept a **Supply Fan Status** input to provide proof the supply fan is operating. When enabled, a loss or lack of fan status will stop heating and cooling operation.

A **Supply Fan Alarm Service Timer** function is available to track the number of supply fan run hours and generate an alarm when the accumulated runtime exceeds the set threshold.

Cooling

The RTU Open's application and configuration determines the specific cooling sequence. The RTU Open can control up to 2 stages of cooling with an additional output for a reversing valve (heat pump applications). The number of stages is configurable or is defined by unit type.

The following conditions must be true for the cooling algorithm to operate:

- **Outdoor Air Temperature**, if valid, is greater than the **Cooling Lockout Temperature** setpoint
- The indoor fan is on
- The unit has a valid **Supply Air Temperature** input
- The unit has a valid **Space Temperature** input

- Heat mode is not active and the 5-minute time guard between modes has expired
- Economizer is unavailable, or if the Economizer is active, mechanical cooling is available if the economizer is open > 90% for at least 7.5 minutes, the SAT and OAT > [**Minimum Cooling SAT** + 5Δ °F (2.7Δ °C)] and SPT > [**Effective Cooling Setpoint** + 0.5Δ °F (.27Δ °C)].

The cooling relays are controlled by the Cooling Control PID Loop and Cooling Capacity algorithm. They calculate the desired number of stages needed to satisfy the space by comparing the **Space Temperature** to the:

- **Effective Occupied Cooling Setpoint** when occupied
- **Effective Unoccupied Cooling Setpoint** when unoccupied

When the cooling algorithm preconditions have been met, the compressors are energized in stages, as applicable. Anti-recycle timers are employed to protect the equipment from short-cycling. There are fixed 3 minute minimum on-times, and 5 minute off-times for each compressor output.

During compressor operation, the RTU Open may reduce the number of active stages if the rooftop supply air temperature falls below the **Minimum Cooling SAT Setpoint**. A compressor staged off in this fashion may be started again after the normal time-guard period has expired, if the **Supply Air Temperature** has increased above the **Minimum Cooling SAT Setpoint**.

Compressor Service Alarm Timer functions are available (1 for each stage of compression). This function tracks the number of compressor run hours and generates an alarm when the accumulated runtime exceeds the threshold set by the adjustable compressor service alarm timers.

Economizer

The RTU Open provides an analog economizer output for rooftop units with economizer dampers. Economizer dampers may be used to provide indoor air quality control and free cooling when outside air conditions are suitable.

The following conditions must be true for economizer operation:

- The **Outdoor Air Temperature** is less than the **Space Temperature** and less than the **Economizer High OAT Lockout Temp** setpoint
- The indoor fan is on
- The unit has a valid **Supply Air Temperature** input
- The unit has a valid **Space Temperature** input

If the RTU Open is configured for VFD or 2-speed fan, the economizer minimum position is adjusted to provide a constant amount of outdoor air. If the fan is on high speed or is configured for single-speed fan, the economizer minimum position will be set to the **Vent Dmpr Pos / DCV Min Pos** setpoint. If it is configured for VFD or 2-speed fan, and the fan is on low speed, the economizer minimum position will be set to the **Low Fan Econ Min Pos**.

If all preceding conditions are true, the economizer PID loop modulates the damper between the minimum position and 100% open..

During economizer operation, the economizer position is reduced as the SAT falls below the **Minimum Cooling SAT** + 5Δ °F (2.8Δ °C), but never closes below the applicable minimum position.

The RTU Open provides FDD (Fault Detection and Diagnostics) for economizer operation in compliance with California Title 24. The FDD logic will detect an economizer that fails to close, fails to open, is stuck fully open, and fails to fully open. Each condition will cause an Economizer Operation alarm to occur and the specific fault condition will be displayed.

Power Exhaust

The RTU Open may enable and disable an exhaust fan, based on either the controller's occupancy or its economizer damper position. If the **Fan Control** is set to **Two Speed** or **Variable Speed**, the **Power Exhaust Setpoint** is automatically adjusted based on the fan's air delivery. The **Calculated PE Setpoint** used for control is displayed in the **Maintenance** section.

If **Continuous Occupied Exhaust** is **Yes**, the **Power Exhaust** binary output (BO-8) is energized while the RTU Open is occupied and de-energized when unoccupied.

If **Continuous Occupied Exhaust** is **No**, the **Power Exhaust** binary output (BO-8) is energized when the economizer damper output exceeds the **Calculated Power Exhaust (PE) Setpoint** value. The output remains energized until the economizer output falls below the **Power Exhaust Setpoint** value by a fixed hysteresis of 10%.

Pre-Occupancy Purge

Pre Occupancy Purge allows the rooftop equipment with an economizer damper to use outdoor air to purge the space of contaminants just prior to the beginning of the occupied period.

The following conditions must be true for pre-occupancy purge to operate:

- **Pre-Occupancy Purge** set to **Enable**
- **Economizer Exists** set to **Yes**
- A local time schedule is configured
- The local time schedule is currently unoccupied and the remaining time is less than the configured **Purge Time**

When the RTU Open schedule is unoccupied and the remaining unoccupied time is less than the purge time, the supply fan starts. The economizer damper opens to the configured **Economizer Purge Min Pos**. The RTU Open continues to operate in this mode until the occupied start time is reached. The **Pre-Occ Purge** state is displayed in the **Maintenance** section.

Unoccupied Free Cooling

Unocc Free Cool Enable allows rooftop equipment with an economizer damper to use outdoor air for free cooling during unoccupied periods.

The following conditions must be true for unoccupied free cooling to operate:

- **Unocc Free Cool Enable** set to **Enable**
- The system is unoccupied
- The outside air temperature is below the **Economizer High OAT Lockout Temp** setpoint
- The outside air temperature is less than the space temperature
- **Enthalpy** (if enabled) is **Low**

When the RTU Open schedule is unoccupied and the space temperature rises at least $1\Delta^{\circ}\text{F}$ ($.5\Delta^{\circ}\text{C}$) above the **Occupied Cooling Setpoint**, the supply fan starts. The economizer damper opens as necessary to cool the space. The RTU Open continues to operate in this mode until the space is satisfied or the outside air conditions are no longer suitable for free cooling.

Optimal Start

The RTU Open may use either of 2 different **Optimal Start** methods. **Learning Adaptive Optimal Start** is used for heat pump applications and adjusts the effective setpoints to achieve the occupied setpoints by the time scheduled occupancy begins. This prevents or minimizes the need for auxiliary heat. The Optimal Start recovery period may begin as early as 4 hours prior to occupancy. The algorithm works by moving the unoccupied setpoints toward the occupied setpoints. The rate at which the setpoints move is based on the outside air temperature, design temperatures, and capacities.

The following conditions must be true for learning adaptive optimal start to operate:

- On the **Properties** page > **Equipment** tab > **Configuration** > **Setpoints** > **Optimal Start**, the default value is set to 1 and must be set greater than **0 (0.00 disables Optimal Start)** and less than or equal to **4**.
- The system is unoccupied

NOTE If the controller does not have a valid outside air temperature, then a constant of 65 °F (18.3 °C) is used. This value is not adjustable.

The actual equation that the controller uses to calculate **Learning Adaptive Optimal Start** is nonlinear. An approximation of the result is shown below.

NOTE The values in the graph below are Fahrenheit.

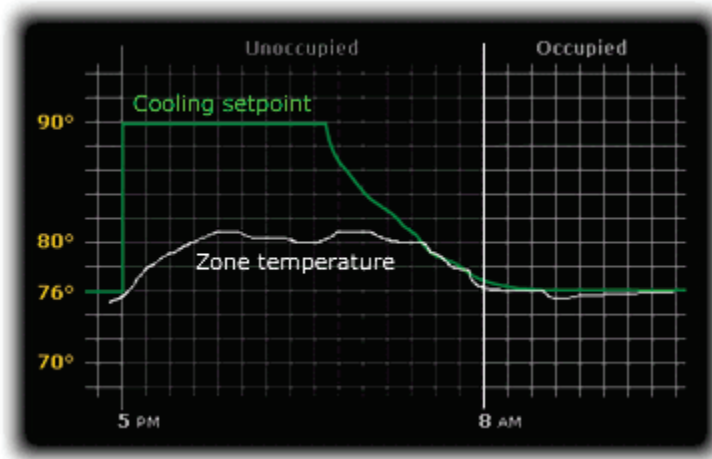

To change **Learning Adaptive Optimal Start** settings:

- 1 In the navigation tree, select the equipment that you want to change.
- 2 Click **Properties** page > **Equipment** tab > **Configuration** > **Setpoints**.

Temperature Compensated Optimal Start is a second start method used for gas or electric heating applications. It switches from unoccupied to the occupied setpoints at a calculated time prior to occupancy. This minimizes the operation of the unit's fan. The Optimal Start recovery period may begin as early as 4 hours prior to occupancy. The time at which the setpoints move is based on the difference between the current space temperature and the desired setpoint, multiplied by the "K" factor, or recovery rate, for the required mode of operation.

The following conditions must be true for Temperature Compensated Optimal Start to operate:

- On the **Properties** page > **Equipment** tab > **Configuration** > **Setpoints** > **Optimal Start**, the default value is set to 1 and must be set greater than **0 (0.00 disables Optimal Start)** and less than or equal to **4**.
- The system is unoccupied

To change Temperature Compensated Optimal Start settings:

- 1 In the navigation tree, select the equipment that you want to change.
- 2 On the **Properties** page > **Equipment** tab > **Configuration** > **Setpoints**, click **Heat Start K factor** or **Cool Start K factor**. This defines the equipment's recovery rate in minutes / deg.

Enthalpy control

You may use an enthalpy switch to indicate the suitability of outdoor air for economizer cooling. You can use either an outdoor air or differential enthalpy switch. A differential enthalpy switch has a sensing device in both the outdoor and return air streams. A differential enthalpy switch indicates when outside air is more suitable to be used than the return air and is available for economizer cooling. If no enthalpy switch is configured, a network point (Object Name: oae) is available. This point is displayed in the i-Vu® application and an Equipment Touch as **Enthalpy** (BACnet).

The sequence of operation for economizer cooling is the same with or without an enthalpy switch, except that an enthalpy switch imposes one more validation on the suitability of outside air for economizer cooling. An **Enthalpy Status** that is **High** disables the economizer and the outside air damper goes to its minimum position. An **Enthalpy Status** that is **Low** enables the economizer if a call for cooling exists and the remaining preconditions are met.

Indoor Air CO2

Indoor Air CO2 is controlled on rooftop equipment with an economizer. **Indoor Air CO2** sequence is enabled by installing an air quality (CO2) sensor. A CO2 sensor may be terminated at the RTU Open, or a subordinate zone controller, when part of a zoned system.

An outdoor air quality sensor may also be installed and terminated at the RTU Open, but it is not required. When an outdoor air quality sensor is not installed, the algorithm uses 400ppm as the fixed outdoor air CO2 level.

The following conditions must be true for the **Indoor Air CO2** algorithm to operate:

- The system is occupied
- The supply fan has been started for at least 30 seconds
- The CO2 sensor has a valid reading

As the air quality within the space changes, the minimum position of the economizer damper changes, which allows more or less outdoor air into the space, depending on the relationship of the indoor air CO2 level to the differential setpoint.

The **Indoor Air CO2** algorithm calculates a minimum position value using a PID loop. The CO2 minimum damper position is then compared against the **Vent Dmpr Pos / DCV Min Pos** setpoint and the greatest value becomes the final minimum damper position of the economizer output.

The degree to which the outside air damper may be opened by the **Indoor Air CO2** algorithm is limited by the **DCV Max Vent Damper Pos** setpoint, which is adjustable between ten and sixty percent (10 – 60%).

Heating

The specific heating sequence is determined by the controller's application and configuration. The RTU Open controls up to two stages of gas or electric heating with an additional output for a **Reversing Valve** (Heat Pump applications).

The following conditions must be true for the heating algorithm to operate:

- The **Outdoor Air Temperature** is less than the **Heating Lockout Temperature** setpoint
- The indoor fan has been ON for at least 30 seconds
- The unit has a valid **Supply Air Temperature** input
- The unit has a valid **Space Temperature** input
- Neither Cool mode nor economizer are active and the time guard between modes has expired

The heating relays are controlled by the Heating Control PID Loop and Heating Stages Capacity algorithm, which calculate the desired number of stages to satisfy the space by comparing the **Space Temperature** to the:

- **Effective Occupied Heating Setpoint** when occupied
- **Effective Unoccupied Heating Setpoint** when unoccupied

When the heating algorithm preconditions have been met, the heating is energized in stages. Anti-recycle timers are employed to protect the equipment from short-cycling. There are fixed one minute minimum on and off times for each heating output.

During heating operation, the RTU Open may reduce the number of active stages if the rooftop **Supply Air Temperature** exceeds the **Maximum Heating SAT** setpoint. A heat stage turned off in this fashion may be started again after the normal time-guard period has expired, if the **Supply Air Temperature** has decreased below the **Maximum Heating SAT** setpoint.

Heat Pump operation

The RTU Open can control heat pumps **HP O/B** and **Y1/W1**.

HP O/B provides a separate output (BO-7) to control a reversing valve. The reversing valve control may be configured to be energized with a call for heating (**B**), or energized with a call for cooling (**O**).

The sequence of operations are as previously described for heating and cooling except that the **Y1** and **Y2** outputs are compressor outputs, energizing mechanical heating or cooling, depending on the state of the reversing valve. **W1** and **W2** are used for auxiliary heat. Up to two stages are available.

Selection **Y1/W1** is for heat pumps that do not require a **O** terminal to energize the reversing valve. The sequences of operations are as described for *Heating* (page 50) and *Cooling* (page 45). The reversing valve output is not used in this application. **W1** and **W2** are used for auxiliary heat. Up to two stages are available.

Dehumidification

The RTU Open provides occupied and unoccupied dehumidification on units that are equipped with the Carrier Humidi-MiZer™ option from the factory. This requires a space relative humidity sensor or a humidistat for control.

The following conditions must be true for the dehumidification control to operate:

- The **Outside Air Temperature** is greater than the **Cooling Lockout Temperature** setpoint
- The **Indoor Fan** has been on for at least 30 seconds
- The unit has a valid **Supply Air Temperature** input
- The unit has a valid **Space Temperature** input
- The unit has a valid **Space Relative Humidity Sensor** or **Humidistat** input
- Heat mode is not active and the time guard between modes has expired

When using a relative humidity sensor to control dehumidification, occupied and unoccupied dehumidification setpoints are used.

When using a humidistat, the setpoints are not used. The humidistat indicates a high-humidity condition.

When a high indoor relative humidity condition is indicated and the above conditions are satisfied, the RTU Open enters the dehumidification mode, energizing the Humidi-MiZer™ output.

The mode continues until the space relative humidity falls below the active setpoint by a 5% fixed Hysteresis when a humidity sensor is used, or when there is no longer a call for dehumidification where a humidistat is used.

See the base unit / Humidi-MiZer™ operations manual for additional information.

Demand Limiting

The RTU Open may employ a demand limit strategy. Demand limiting in the RTU Open works through setpoint expansion. The controller's heating and cooling setpoints are expanded in steps or levels. The degree to which the setpoints are expanded is defined by the **Demand Level Setpoints**.

Each **Demand Level** (1 through 3) adjusts the heating and cooling setpoints outwards. By default, **Demand 1** yields a 1Δ °F (.5Δ °C) expansion, **Demand 2** yields a 2Δ °F (1.1Δ °C) expansion, and **Demand 3** yields a 4Δ °F (2.2Δ °C) expansion.

The BACnet **Demand Limit** variable sets the desired level of setpoint expansion in the receiving controller. **Level 0** leaves the standard occupied and unoccupied heating and cooling setpoints in effect. Levels 1 through 3 expands occupied heating and cooling setpoints.

Door switch

A **Door Contact** may be configured on any unused binary input. A typical application is a door or window contact mounted within the space served by a single zone rooftop. The **Door Contact** disables mechanical cooling and any heating, when active (an open door or window is detected). Economizer cooling, if available, continues to operate. The input provides a configurable alarm delay (60 second default) before heating and cooling is disabled.

Remote Occupancy

Remote occupancy may be configured on any unused binary input channel. A typical application is a remote contact, controlled by a third party, or an occupancy sensor to set the controller's occupied mode. The **Remote Occupancy** function requires both an input configured for **Remote Occupancy**, and **Occupancy Source** set to **Remote Occ Input** to operate.

Once configured, the controller will operate in the occupied or unoccupied mode, as determined by the state of the **Remote Occupancy** input.

Fire Shutdown

Fire Shutdown may be configured on Binary Input 5. A typical application involves a smoke detector or fire shutdown contact, which, when active, immediately shuts down equipment operation.

Compressor Safety

Compressor Safety may be configured on Binary Input 3. A compressor safety tripped indicator circuit is available on most Carrier rooftop equipment.

A **Compressor Safety Alarm** is shown on **Properties** page > **Equipment** tab > **Alarms** and indicates that the equipment requires attention.

Cooling, heating, and supply fan outputs are not interrupted except where the RTU Open is configured for Heat Pump operation. When configured for Heat Pump, and in the heating mode, a compressor safety fault will cause the available stages of electric heating to be enabled in place of mechanical heating.

Normal operation resumes when the compressor safety circuit is de-energized.

Fan Status

Fan Status may be configured on any unused binary input channel. A typical application would be an airflow switch, current sensing relay, or other device that provides a supply fan running verification.

Enabling this function displays the supply fan's status on the equipment graphic.

If the controller loses fan status during operation, heating and cooling are disabled, the economizer damper (if available) is closed, and an alarm for loss of status is indicated.

If the fan status is on when the controller is commanding the fan off, the unit remains in the off state. An alarm is generated indicating that the fan is running when it should be off.

Filter status

Filter status may be configured on any unused binary input channel. A typical application is a differential pressure switch that senses the pressure drop across a filter bank.

When the pressure across the filter bank exceeds the setpoint of the differential pressure switch, the **Filter** status is displayed as **Dirty** on the controller graphic. An alarm indicates a dirty filter.

Alarms

NOTE Some of the **Alarms** functions described in this section will only be visible on the **Properties** page > **Equipment** tab > **Alarms** when the appropriate inputs are configured. Alarms are not initiated when the input is not configured.

Safety Chain - You may use the RTU Open's safety chain circuit to shut down the unit for a safety condition. Examples: Low or High Temperature Cutouts (Freezestat / Firestat). This alarm indicates the safety chain circuit (Input 4) is open. Cooling, heating, and supply fan operation stop after appropriate time guards. Normal operation resumes when the safety chain circuit is complete.

Fire/Smoke Shutdown - You may configure the RTU Open to accept a **Fire Shutdown** contact on Input 5. Examples: Smoke detectors or fire shutdown relays. This alarm indicates this device (Input 5) has tripped. Cooling, heating, and supply fan operation immediately stop. Reset fire shutdown contact to resume normal operation.

Gas Valve - If configured for the IGC input function, the RTU Open will compare the state of this input with the requirement for heat (W1 or W2). If the IGC input, which detects an active flame in the gas heat section, is present 1 minute after any call for heating has ended, a gas valve failure alarm will occur, indicating a stuck gas valve.

Compressor Status - You may configure the RTU Open to monitor the base unit's compressor safety circuit. This alarm indicates the base unit's compressor safety circuit is energized. Cooling, heating, and supply fan outputs are not interrupted except when the RTU Open is configured for Heat Pump. Normal operation resumes when the compressor safety circuit is de-energized.

If the Heat Pump is a HP O/B Ctrl type and is in the heating mode, it will automatically replace the compressor stage(s) with the equivalent number of auxiliary heat stages, as available.

- If it's a Carrier Heat Pump HP Y1/W1 Ctrl, there is only 1 auxiliary heat stage output and the staging is done by the machine itself. The RTU Open control does not take any action.
- For a non-Carrier Heat Pump, when configured for 2 stages of aux heat and two compressors, Compressor 1 is replaced by Aux Heat Stage 1 and Compressor 2 is replaced by Aux Heat Stage 2.

The compressor output stays on when the safety alarm is present. For cooling, the alarm indicates the compressors are not operating. See *Heat Pump operation* (page 50) for further information.

Space Temperature - This alarm indicates if the space temperature is outside the configured alarm limits. If active (Alarm), displays additional values for the space temperature when the alarm condition occurred and the alarm limit exceeded.

The following values are related to the **Space Temperature** alarm:

- **Alarming Temperature** - Displays the value of the space temperature that caused the alarm condition to occur and is only visible when the **Space Temperature** is in an alarm state.
- **Alarm Limit Exceeded** - Displays the value of the alarm setpoint that was exceeded by the alarming temperature and is only visible when the **Space Temperature** is in an alarm state.

SPT Sensor - This alarm indicates a communication failure of a connected SPT sensor that previously had been actively communicating. The alarm is reset when normal SPT sensor communications resume, if power is cycled to the controller, or if the **Shutdown** point is set to **Active**.

ZS Sensor – This alarm indicates a communication failure of a connected ZS sensor that had previously been actively communicating. The alarm is reset when normal ZS sensor communications resume, if power is cycled to the controller, or if the **Shutdown** point is set to **Active**.

ZS Configuration – This alarm indicates that at least 1 ZS sensor is configured in the Sensor Binder properties and is not communicating. The alarm is reset when the configured ZS sensor is communicating or the configuration is changed to reflect the sensor is no longer connected to the Rnet.

Space Temp Sensor – This alarm indicates an invalid sensor condition in a physically connected space temperature sensor (SPT Sensor/T5*). Cooling, heating, and supply fan operation stop after the appropriate time guards. Normal operation resumes when the controller detects a valid sensor.

Supply Air Temperature – This alarm indicates that the supply air temperature is outside the configured alarm limits. The alarm is reset to normal when the supply air temperature returns within the configured alarm limits plus a 5Δ °F (2.7Δ °C) hysteresis. This alarm is inhibited until the fan has been running for 15 minutes to allow for system stabilization after startup.

Supply Air Temp Sensor – This alarm indicates a shorted or open circuit in the SAT input. Cooling, heating, and supply fan operation stops after the appropriate time guards. Normal operation resumes when the controller detects a valid sensor.

Indoor Air Quality – The RTU Open generates an **Indoor Air Quality** alarm if the CO₂ level exceeds the configured alarm limits. (This alarm is only shown when a valid indoor air quality sensor value is available).

Indoor Air Quality Sensor – The RTU Open generates an **Indoor Air Quality Sensor** alarm if a valid sensor value is no longer available. For locally connected sensors, the mA input at the associated channel falls below 3.5 mA or rises above 21 mA. For network sensors, the controller is no longer receiving a value from the network. Cooling, heating, and supply fan continue to operate. However, the controller's IAQ control function is disabled until the fault condition is corrected.

Space Relative Humidity – The RTU Open generates a **Space Relative Humidity** alarm if the space humidity level exceeds the configured low or high alarm limits. (This alarm is only shown when a valid relative humidity sensor value is available).

Space Relative Humidity Sensor – The RTU Open generates a **Space Relative Humidity Sensor** alarm if a valid sensor value is no longer available. For locally connected sensors, the mA input at the associated channel falls below 3.5 mA or rises above 21 mA. For network sensors, the controller is no longer receiving a value from the network. Cooling, heating, and supply fan operation continues, however, the controller's Humidi-MiZer™ binary output is disabled until the fault condition is corrected.

Filter – If the RTU Open is configured to monitor the filter through a hardware input switch contact, it generates a **Filter** alarm if the associated input channel detects a dirty filter condition (opposite state of the **Input "x" Switch Configuration**). Otherwise, if no hardware switch monitoring is used, the RTU Open generates a filter alarm when the accumulated runtime exceeds the **Unit Configuration > Filter Service Alarm Timer** value (when not set to 0). This alarm is most commonly used to indicate a filter replacement is due. Reset the filter service runtime accumulator by setting the **Maintenance > Reset Filter Runtime Alarm** to **On**, back to **Off**, and clicking **OK** after each setting. Set **Unit Configuration > Filter Service Alarm Timer** value to **0** to disable the filter service alarm function.

Local OAT Sensor – This alarm indicates a shorted or open circuit in the locally connected OAT input.

Outdoor Air Temp Sensor – This alarm indicates a valid OAT sensor value is no longer available. An alarm condition can occur from a failed locally connected sensor or if a network OAT value is no longer being received by the controller. Cooling, heating, and supply fan operation continues. OAT lockouts will not operate while the sensor is in alarm. Normal operation resumes when the controller detects a valid sensor.

Economizer Operation – This alarm is active when an economizer fault is detected, as required by the CEC Title 24 Economizer FDD logic. Once detected, this alarm will stay active until the **Shutdown** input is set to **Active** or the fan is stopped.

Economizer – This point indicates the specific fault detected and announced by the Economizer Operation alarm above. Detected fault conditions include **Failed to Fully Open**, **Failed to Open**, **Failed to Close**, and **Stuck Open**.

Outdoor Air Quality Sensor – The RTU Open generates an **Outdoor Air Quality Sensor** alarm if the mA input at the associated channel falls below 3.5 mA or rises above 21 mA. For network sensors, the controller is no longer receiving a value from the network. Cooling, heating, and supply fan operation continues. However, the controller's IAQ control function uses 400ppm as the fixed outdoor air CO₂ level until the fault condition is corrected.

Setpoint Slider – The RTU Open generates this alarm when an open circuit is detected at Input 11 and the RTU Open **Configuration > Unit Configuration > Input Configuration > Space Sensor Type** is set to T56. Note that only an open circuit results in an alarm. A short across this input offsets the setpoints negatively by the amount configured in the **Unit Configuration > Setpoint Adjustment Range**.

Switch Configuration - The RTU Open generates this alarm when any two of the **Unit Configuration > Input Functions 3, 5, 8, or 9** are configured identically. Neither input may work reliably and downstream control may be affected, depending on the function duplicated. The alarm clears and normal control is restored when the input function duplication is corrected.

Analog Input Configuration - The RTU Open generates this alarm when the **Unit Configuration > Input Functions 1 and 2** are configured identically. Neither input may work reliably and downstream control may be affected, depending on the function duplicated. The alarm clears and normal control is restored when the input function duplication is corrected.

Supply Fan Runtime - The RTU Open generates a this alarm when the accumulated runtime exceeds the **Unit Configuration > Supply Fan Service Alarm Timer** value (when not set to 0). This alarm is most commonly used to indicate an equipment maintenance interval is due. The supply fan runtime accumulator may be reset by setting the **Maintenance > Reset Supply Fan Runtime Alarm** to **Clear**, and then back to **Run** – acknowledging each selection by clicking the **OK** button when it appears. Setting **Unit Configuration > Supply Fan Service Timer** value to **0** disables the supply fan runtime alarm function.

Compressor 1 Runtime - The RTU Open generates this alarm when the accumulated runtime exceeds the **Unit Configuration > Compressor 1 Service Alarm Timer** value (when not set to **0**). This alarm is most commonly used to indicate an equipment maintenance interval is due. The **Compressor 1 Runtime** accumulator may be reset by setting the **Maintenance > Reset Comp 1 Runtime Alarm** to **Clear**, and then back to **Run** – acknowledging each selection by clicking the **OK** button when it appears. Setting **Unit Configuration > Compressor 1 Service Timer** value to **0** disables the **Compressor 1 Runtime** alarm function.

Compressor 2 Runtime - The RTU Open generates this alarm when the accumulated runtime exceeds the **Unit Configuration > Compressor 2 Service Alarm Timer** value (when not set to **0**). This alarm is most commonly used to indicate an equipment maintenance interval is due. The Compressor 2 runtime accumulator may be reset by setting the **Maintenance > Reset Comp 2 Runtime Alarm** to **Clear**, and then back to **Run** – acknowledging each selection by clicking the **OK** button when it appears. Setting **Unit Configuration > Compressor 2 Service Timer** value to **0** disables the Compressor 2 runtime alarm function. Note that this function is unavailable if the **Service Configuration > Compressor States** value is not set to **Two Stages**.

Airside Linkage Alarm - An RTU Open may act as an air source in a zoned system. Carrier systems use a function called Linkage™ to pass data between a master zone and its air source over an MS/TP network connection. When the RTU Open is part of a linked system, it will indicate an airside linkage alarm if it loses communications with its linkage master or if it receives data from more than 1 master zone.

Linkage

The RTU Open may serve as an air source to an Open Variable Volume Terminal (VVT) system. When the RTU Open is part of a VVT system and the controllers are wired together to form a network, the controllers may use a method of communication known as Linkage™. Linkage is a method by which an air source and its subordinate zone terminals exchange data to form a coordinated HVAC system. The system's air source controller, zone controllers, and bypass controller are linked so that their data exchange can be managed by one zone controller configured as the VVT Master.

The VVT Master gathers the following information from the slave zone controllers:

- occupancy status
- setpoints
- zone temperature
- relative humidity
- CO₂ level
- damper position
- optimal start data

The VVT Master performs mathematical calculations and algorithms on the data and then sends the composite information to the air source. The VVT Master receives information from the air source such as System Mode, Supply Air Temperature, and Outside Air Temperature (if available), and passes that information to all linked controllers.

NOTE The following paragraphs describe the interaction between the air source (RTU Open) and its subordinate zones. Additional information regarding Open Zoned Systems may be found in the *VVT Zone and VVT Bypass Controller Installation Guides*.

The VVT Master determines system operation by prioritizing heating and cooling requirements from all the zones based on their occupancy and demand. The VVT Master scans the system continuously to determine if any zones are occupied. Occupied zones are a higher priority than unoccupied zones. The VVT Master evaluates all the occupied zones' heating or cooling demands and sends a request to the air source (RTU Open) for:

- Cooling, if the number of occupied zones with cooling demands exceeds the number of occupied zones with heating demands, and the demand is greater than or equal to the number of configured **Linkage Callers**.
- Heating, if the number of occupied zones with a heating demand exceeds or is equal to the number of **Linkage Callers**.

If no zones are occupied or no occupied zones require heating or cooling, the VVT Master performs the evaluation described above for the unoccupied zones.

The VVT Master then gathers the following information and sends it to the air source (RTU Open):

- The setpoints and zone temperature from the zone with the greatest demand for the requested air source mode (heating or cooling). (This zone is called the reference zone.)
- The system occupancy status
- Most open damper position from any zone
- RH and CO₂ values (if applicable)

The air source responds by sending the air source mode, supply air temperature, and outside air temperature. The air source verifies the mode by comparing its supply air temperature to the space temperature received through Linkage. See the air source documentation for operation and parameters used to verify its mode. This verification allows the VVT system to determine if the desired air source mode is actually being provided. For example, if the VVT Master sends a request for heating and the air source does not have heat or its heat has failed, the air source's actual mode indicates that and its current mode is sent to the zones so that they can control accordingly.

The system remains in that mode until all zones of that demand are satisfied or until the system mode reselect timer (default 30 minutes) causes a forced re-evaluation of the system. If there is no demand for the opposite mode, the reselect timer starts again and the current mode continues until all zones are satisfied or until the reselect timer expires, repeating the process. If there is a demand for the opposite mode, the VVT Master sends the reference zone's space temperature and setpoints to the air source and restarts the reselect timer. The air source re-evaluates its demand based on the new information and goes to the Vent mode until the new mode can be verified as described above. The amount of time this takes is determined by the air source's operating parameters.

The VVT Master continuously evaluates the system and updates the air source with the most current system demand. Based on the evaluation, the reference zone can change from one zone to another. The evaluation process continues until there is no demand from any zone or the system mode reselect timer causes a re-evaluation of the system conditions.

If no heating or cooling is required or the current air source mode is satisfied, the VVT Master calculates the weighted average of the occupied and unoccupied heating and cooling setpoints. It also calculates a zone temperature that is midway between the setpoints (occupied or unoccupied based on the system's current occupancy status). This information, plus the occupancy status, is sent to the air source so that its current mode is disabled and the unit ceases heating or cooling operation. If the system is occupied, the air source fan and OA damper, if applicable, operate to maintain proper ventilation.

Linkage also provides a safety and system override function during any RTU heating mode. Whenever the RTU Open is in a heating mode, the control monitors the supply air temperature (SAT). Normally (and initially) during heating, the RTU sends the Linkage Heat mode which causes only those zones that require heat to modulate their dampers to utilize the heated primary air. If during heating the SAT increases and exceeds the Maximum Heating SAT minus 7Δ°F, Linkage transmits the Linkage Warm-up mode to all terminals. This allows more zones to utilize the heated primary air and attempts to prevent any further SAT increase. Finally, if the SAT rises above the Maximum Heating SAT, Linkage transmits the Linkage Pressurization mode to maximize the amount of airflow through the RTU and prevent any safety limit switches from operating.



CAUTION It is important to properly set the value for the Maximum Heating SAT to match the value specified from the equipment product data recommendations. Many rooftops have heat capacity that will provide a higher heat rise, resulting in an SAT in excess of the Maximum Heating SAT default value (120°F).

Linkage air source mode determination

Linked air source modes – In a linked system, the air source determines its operating mode and qualifies that mode based on its own SAT. The following modes can be sent by the air source depending on its capability and configuration:

OFF	Air source fan is off.
WARMUP	Air source fan is on and providing first cycle of heat when changing from unoccupied to occupied. It may also be used as a safety to increase airflow during a heating mode.
HEAT	Air source fan is on and providing heat.
FREECOOL	Air source fan is on and providing cooling using only the economizer and usually during an unoccupied period.
COOL	Air source fan is on and providing cooling.
PRESSURIZATION	Air source supply fan is on usually as a result of a fire-life safety input being active. It may also be used as a safety to increase airflow during a heating mode.
EVACUATION	Air source supply fan is off usually as a result of a fire-life safety input being active.
VENT	Air source fan is on and providing ventilation without heating or cooling.

See the air source's installation manual for more specific operation.

Troubleshooting

If you have problems mounting, wiring, or addressing the RTU Open, contact Carrier Control Systems Support.

NOTE To help you troubleshoot, obtain a Module Status (Modstat) from the controller and review the System Error and Warning details.

Communication LED's

The LED's on the RTU Open show the status of certain functions. Verify the LED patterns by cycling power to the controller and noting the lights and flashes.

If this LED is on...	Status is...
Power	The RTU Open has power
Rx	The RTU Open is receiving data from the network segment
Tx	The RTU Open is transmitting data over the network segment
DO#	The binary output is active

The **Run** and **Error** LED's indicate controller and network status.

If Run LED shows...	And Error LED shows...	Status is..
2 flashes per second	Off	Normal
2 flashes per second	2 flashes, alternating with Run LED	Five minute auto-restart delay after system error
2 flashes per second	3 flashes, then off	The controller has just been formatted
2 flashes per second	On	Exec halted after frequent system errors or control programs halted
5 flashes per second	Off	Firmware transfer in progress, Boot is running
7 flashes per second	7 flashes per second, alternating with Run LED	Ten second recovery period after brownout
14 flashes per second	14 flashes per second, alternating with Run LED	Brownout
On	On	Failure. Try the following solutions: <ul style="list-style-type: none"> • Turn the RTU Open off, then on. • Format the RTU Open. • Download memory to the RTU Open. • Replace the RTU Open.

To get the serial number

If you need the RTU Open's serial number when troubleshooting, the number is on:

- a sticker on the back of the main controller board
- a Module Status report (Modstat) under **Core** (or **Main**) **board hardware**

```
Core board hardware:
Type=178, board=31, manufactured on 06/27/2013 S/N 021362247P
RAM: 512 kBytes; FLASH: 1024 kBytes, type = 3
```

To obtain a modstat in the i-Vu® interface:

- 1 Select the RTU Open in the navigation tree.
- 2 Right-click and select **Module Status**.

To replace the RTU Open's battery

To determine when to replace the battery, remove power and measure the voltage. If the voltage is below 2.9 volts, you need to replace the battery.



CAUTION Power must be **ON** to the RTU Open when replacing the battery, or your date, time, and trend data will be lost.

- 1 Remove the battery from the controller, making note of the battery's polarity.
- 2 Insert the new battery, matching the battery's polarity with the polarity indicated on the RTU Open.

Compliance

FCC Compliance

This equipment has been tested and found to comply with the limits for a Class A digital device, pursuant to Part 15 of the FCC Rules. These limits are designed to provide reasonable protection against harmful interference when the equipment is operated in a commercial environment. This equipment generates, uses, and can radiate radio frequency energy and, if not installed and used in accordance with the instruction manual, may cause harmful interference to radio communications. Operation of this equipment in a residential area is likely to cause harmful interference in which case the user will be required to correct the interference at his own expense.



CAUTION Changes or modifications not expressly approved by the responsible party for compliance could void the user's authority to operate the equipment.

CE Compliance



WARNING This is a Class A product. In a domestic environment, this product may cause radio interference in which case the user may be required to take adequate measures.

BACnet Compliance

Compliance of listed products to requirements of ASHRAE Standard 135 is the responsibility of BACnet International. BTL® is a registered trademark of BACnet International.

Appendix A: RTU Open Points/Properties in i-Vu®/Field Assistant

All possible points and properties that are available on the i-Vu® or Field Assistant **Properties** tab are defined in the following pages.

See *Appendix C* (page 92) for the points and properties available on the Equipment Touch interface.

NOTE Engineering units shown in this document in the defaults and ranges are strictly for reference. You must enter an integer only.

Status

Navigation: i-Vu® / Field Assistant: **Properties > Control Program > Status**

Point Name/Description	Range
Equipment Status – The controller's current status.	R: Disabled Test Run
System Mode – The controller's current operating mode.	R: Off Fan Only Economizer Cooling Cooling Heating Dehumidification Test Shutdown Unocc Free Cooling Fire Shutdown IAQ Override Pre-occ Purge IGC Override
Supply Fan Status – The current fan status if an input is configured for Fan Status .	R: Off/Running
Fan / Speed – The current commanded fan speed if Fan Control is set to Two Speed .	R: Off/Low/High
Supply Fan VFD – The current commanded output to the VFD to control the fan's speed if Fan Control is set to Variable Speed .	R: Off/Low/High
Space Temperature - Prime Variable – The space temperature value currently used for control.	R: -56 to 245 °F (-48.9 to 118.3 °C)
Supply Air Temperature – Displays the current supply air temperature.	R: -56 to 245 °F (-48.9 to 118.3 °C)
Outdoor Air Temperature – The outdoor air temperature used for control.	R: -56 to 245 °F (-48.9 to 118.3 °C)
Space Relative Humidity – The current space relative humidity if a valid value exists either as a connected ZS sensor with RH or a hardware sensor connected to this controller (Configuration > Unit Configuration > Input 1 (or 2) Function is set to IAQ Sensor) or a value received through the Network or Linkage.	R: 0 to 100%rh

Point Name/Description	Range
Indoor Air Quality CO2 (ppm) – The current space CO ₂ concentration if a valid value exists either as a connected ZS sensor with CO ₂ or a hardware sensor connected to this controller (Configuration >Unit Configuration > Input 1 (or 2) Function is set to IAQ Sensor) or a value received through the Network or Linkage.	R: 0 to 5000ppm
Outdoor Air Quality CO2 (ppm) – The current outdoor air CO ₂ concentration if the Configuration >Unit Configuration >Input 1 (or 2) Function is set to OAQ Sensor .	R: 0 to 5000ppm
Economizer Output – The current economizer output with respect to the outdoor air damper (if equipped).	R: 0 to 100% Open
Shutdown – When Active , all alarms are reset. (Any currently active alarms will continue to display.) Provides a means to stop heating and cooling in an orderly manner.	D: Inactive R: Inactive/Active

Unit Configuration

Navigation: i-Vu® / Field Assistant: **Properties > Control Program > Configuration > Unit Configuration**

Point Name/Description	Range
Fan Mode – The supply fan's operating mode. Options: Auto - The fan cycles on/off in conjunction with heating or cooling. Continuous - The fan runs continuously during occupancy and intermittently during unoccupied periods with heating or cooling. Always On - The fan runs continuously regardless of occupancy or calls for heating and cooling.	D: Continuous R: Auto Continuous Always On
Power Fail Restart Delay – How long the controller delays normal operation after the power is restored. Typically used to prevent excessive demand when recovering from a power failure.	D: 5 sec R: 0 to 30 sec
Fan Off Delay – The number of seconds that the fan continues to run after heating or cooling has ended.	D: 90 seconds R: 10 to 300 seconds
Minimum Cooling SAT – In cooling mode, the cooling outputs are controlled so that the supply air temperature does not drop below this value.	D: 50°F (10°C) R: 45 to 75°F (7.2 to 23.9°C)
Maximum Heating SAT – In heating mode, the heating outputs are controlled so the supply air temperature does not rise above this value.	D: 120°F R: 85 to 150°F
Vent Dmpr Pos / DCV Min Pos – The minimum outdoor air damper position maintained during occupied periods.	D: 20% Open R: 0 to 100% Open

Point Name/Description	Range
Economizer Purge Min Pos – The minimum outdoor air damper position maintained during an unoccupied purge cycle when the Pre-Occ Purge mode is active.	D: 40% Open R: 0 to 100% Open
Low Fan Econ Min Pos – The minimum outdoor air damper position maintained during occupied periods when the fan is running at low speed (if configured for 2-speed fan control) or the minimum VFD speed (if configured for variable speed fan control).	D: 33% Open R: 0 to 100% Open
DCV Max Vent Damper Pos – The maximum outdoor air damper position allowed while DCV is active.	D: 50% Open R: 0 to 75% Open
Supply Fan Service Alarm Timer – A Supply Fan Runtime alarm is generated when the supply fan run hours exceed this value. Set to 0 to disable.	D: 600 hr R: 0 to 9999 hr
Compressor 1 Service Alarm Timer – A Compressor 1 Runtime alarm is generated when the compressor 1 run hours exceed this value. Set to 0 to disable.	D: 0 hr R: 0 to 9999 hr
Compressor 2 Service Alarm Timer – A Compressor 2 Runtime alarm is generated when the compressor 2 run hours exceed this value. Set to 0 to disable.	D: 0 hr R: 0 to 9999 hr
Filter Service Alarm Timer – The amount of time the fan will run before generating a Filter Alarm . Set to 0 to disable the alarm and reset accumulated fan hours.	D: 600 hr R: 0 to 9999 hr
Door Alarm Delay – Determines the amount of delay before a door alarm is generated.	D: 60 seconds R: 0 to 3600 seconds
Pushbutton Override – Enables or disables the use of a pushbutton override from a local space temperature sensor.	D: Enable R: Disable/Enable
Setpoint Adjustment – Enables or disables the setpoint adjustment mechanism on the local space sensor. Not displayed unless ZS or SPT sensor is connected.	D: Enable R: Disable/Enable
Setpoint Adjustment Range - The maximum amount that a user can adjust the setpoint on the local ZS or SPT sensor. Not displayed unless ZS or SPT sensor is connected.	D: 5Δ °F (2.7Δ °C) R: 0 to 5Δ °F (0 to 2.7Δ °C)
Cooling Lockout Temperature – Cooling is inhibited below this outdoor air temperature.	D: 45 °F (7.2 °C) R: -65 to 80 °F (-53.9 to 26.6 °C)
Economizer High OAT Lockout Temp – The outdoor air temperature above which economizer cooling is inhibited.	D: 75 °F (23.9 °C) R: 55 to 80 °F (12.7 to 26.6 °C)
HP Rev Cycle Lockout Temp – The outdoor air temperature below which reverse cycle heating is locked out. Once reverse cycle heating has been locked out, the OAT must rise 2Δ °F (1.1Δ °C) above this value to again allow heat pump reverse cycle heating. Requires that the unit be configured as a Heat Pump.	D: -3 °F (-19.4 °C) R: -20 to 65 °F (-28.9 to 18.3 °C)
HP Aux Heat Lockout Temp – The outdoor air temperature above which auxiliary heating is locked out. Once aux heat has been locked out, the OAT must fall 2Δ °F (1.1Δ °C) below this value to again allow aux heating. Requires that the unit be configured as a Heat Pump.	D: 40 °F (4.4 °C) R: -20 to 65 °F (-28.9 to 18.3 °C)

Point Name/Description	Range
Heating Lockout Temperature – Heating is inhibited above this outdoor air temperature.	D: 65 °F (18.3 °C) R: 35 to 150 °F (1.6 to 65.5 °C)
Pre Occupancy Purge – Enables or disables the use of a purge cycle immediately prior to the start of a scheduled occupied period.	D: Disable R: Disable/Enable
Purge Time – The maximum amount of time used for a pre-occupancy purge.	D: 60 minutes R: 0 to 240 minutes
Unocc Free Cool – Enables or disables the use of the economizer to provide unoccupied free cooling (NTFC).	D: Disable R: Disable/Enable
Minimum Setpoint Separation – The minimum amount of temperature separation between the heating and cooling setpoints.	D: 5Δ °F (2.7Δ °C) R: 2 to 10Δ °F (1.1 to 5.5Δ °C)
Occupancy Source - The method that the controller uses to determine occupancy. Options: Always Occupied = Controller operates continuously as occupied. BACnet Schedule = Controller follows a schedule set up in Field Assistant or the i-Vu® application. BAS On/Off = Occupancy is set over the network by another device or a third party BAS. Remote Occ Input = Occupancy is set by a remote contact.	D: Always Occupied R: Always Occupied BACnet Schedule BAS On/Off Remote Occ Input

Input Configuration	
Input 1 Function – The type of sensor (4-20 mA) connected to terminals J4 – 4, 5, and 6.	D: No Sensor R: No Sensor IAQ Sensor OAQ Sensor Space RH Sensor
Input 2 Function – The type of sensor (4-20 mA) connected to terminals J4 – 1, 2, and 3.	D: No Sensor R: No Sensor IAQ Sensor OAQ Sensor Space RH Sensor
Input 3 Function – The usage of Input 3. You must also set Input 3 Switch Configuration . Options: No Function – The input is not used. Compressor Safety – Safety device status. Fan Status – Proves supply fan operation. Filter Status – Indicates a dirty filter. Remote Occupancy – Sets occupancy using a hardware contact. Door Contact – Disables mechanical cooling and electric or gas heating, when active.	D: Compressor Safety R: No Function Compressor Safety Fan Status Filter Status Remote Occupancy Door Contact

<p>Input 3 Switch Configuration – The normal (de-energized) state for the set of contacts terminated at Input 3.</p>	<p>D: NO R: NO/NC (normally open/normally closed)</p>
<p>Input 5 Function – The usage of Input 5. You must also set Input 5 Switch Configuration.</p> <p>Options: No Function – The input is not used. Fire Shutdown – Fire Safety device status. Inhibits operation when tripped. Fan Status – Proves supply fan operation. Filter Status – Indicates a dirty filter. Remote Occupancy – Sets occupancy using a hardware contact. Door Contact – Disables mechanical cooling and electric or gas heating, when active.</p>	<p>D: Fire Shutdown R: No Function Fire Shutdown Fan Status Filter Status Remote Occupancy Door Contact</p>
<p>Input 5 Switch Configuration – The normal (de-energized) state for the set of contacts terminated at Input 5.</p>	<p>D: NC R: NO/NC (normally open/normally closed)</p>
<p>Input 8 Function – The usage of Input 8. You must also set Input 8 Switch Configuration.</p> <p>Options: No Function – The input is not used. Enthalpy Switch – Indicates enthalpy status (high or low). Fan Status – Proves supply fan operation. Filter Status – Indicates a dirty filter. Remote Occupancy – Sets occupancy using a hardware contact. Door Contact – Sets occupancy using a hardware contact.</p>	<p>D: Enthalpy Switch R: No Function Enthalpy Switch Fan Status Filter Status Remote Occupancy Door Contact</p>
<p>Input 8 Switch Configuration – The normal (de-energized) state for the set of contacts terminated at Input 8.</p>	<p>D: NO R: NO/NC (normally open/normally closed)</p>
<p>Input 9 Function – The usage of Input 9. You must also set Input 9 Switch Configuration.</p> <p>Options: No Function – The input is not used. Humidistat – Indicates high humidity condition. Fan Status – Proves supply fan operation. Filter Status – Indicates a dirty filter. Remote Occupancy – Sets occupancy using a hardware contact. Door Contact – Sets occupancy using a hardware contact. IGC Override – Monitors the flame output from the Integrated Gas Control board. The input detects if a flame is still present after heating has been disabled.</p>	<p>D: Humidistat R: No Function Humidistat Fan Status Filter Status Remote Occupancy Door Contact IGC Override</p>
<p>Input 9 Switch Configuration – The normal (de-energized) state for the set of contacts terminated at Input 9. NOTE If Input 9 Function is set to IGC Override, Input 9 Switch Configuration is automatically set to NC and is not configurable.</p>	<p>D: NO R: NO/NC (normally open/normally closed)</p>
<p>Space sensor type - The type of local space temperature sensor.</p>	<p>D: T55 R: T55 T56 (Use for T59) SPT Sensor None ZS Sensor</p>

ZS sensor type – The type of local space temperature sensor.	D: None R: ZS Base ZS Plus ZS Pro
T5x Override Duration – If using a T55, T56, or T59 sensor, this is the amount of time that the controller runs in the occupied mode when a user presses the sensor's override button for 1 to 10 seconds.	D: 1 hr R: 0 to 24 hours

<p>ZS Sensor Binder / ZS Zone Temp / ZS Zone Humidity / ZS Zone CO2</p> <p>Ctrl+click on the name of these properties to access the microblock popup Properties page > Details tab. See below for instructions on configuring your ZS Sensors.</p> <p>See the microblock Help for more detailed explanations.</p>																																																									
<p>ZS Sensor Binder - Use the Associated Sensors table to configure the Rnet to use additional ZS Sensors.</p> <table border="1"> <thead> <tr> <th colspan="8">Associated Sensors</th> </tr> <tr> <th>Index</th> <th>Area</th> <th>Network Type</th> <th>Address</th> <th>Lock Display</th> <th>Version</th> <th>Status</th> <th>Error</th> </tr> </thead> <tbody> <tr> <td>1</td> <td>Main ZS Sensor</td> <td>Rnet</td> <td>1</td> <td><input type="checkbox"/></td> <td>ZSPFH 1234567890v03.03.10</td> <td>Sensor Configured</td> <td>None</td> </tr> <tr> <td>2</td> <td>ZS Sensor 2</td> <td>Unused</td> <td>2</td> <td><input type="checkbox"/></td> <td></td> <td>Sensor Offline</td> <td>None</td> </tr> <tr> <td>3</td> <td>ZS Sensor 3</td> <td>Unused</td> <td>3</td> <td><input type="checkbox"/></td> <td></td> <td>Sensor Offline</td> <td>None</td> </tr> <tr> <td>4</td> <td>ZS Sensor 4</td> <td>Unused</td> <td>4</td> <td><input type="checkbox"/></td> <td></td> <td>Sensor Offline</td> <td>None</td> </tr> <tr> <td>5</td> <td>ZS Sensor 5</td> <td>Unused</td> <td>5</td> <td><input type="checkbox"/></td> <td></td> <td>Sensor Offline</td> <td>None</td> </tr> </tbody> </table> <ul style="list-style-type: none"> Network Type - Set to Rnet Address - Enter the DIP switch settings that are on the additional ZS sensors (up to 5 total) Lock Display - Check to make the sensor display-only 	Associated Sensors								Index	Area	Network Type	Address	Lock Display	Version	Status	Error	1	Main ZS Sensor	Rnet	1	<input type="checkbox"/>	ZSPFH 1234567890v03.03.10	Sensor Configured	None	2	ZS Sensor 2	Unused	2	<input type="checkbox"/>		Sensor Offline	None	3	ZS Sensor 3	Unused	3	<input type="checkbox"/>		Sensor Offline	None	4	ZS Sensor 4	Unused	4	<input type="checkbox"/>		Sensor Offline	None	5	ZS Sensor 5	Unused	5	<input type="checkbox"/>		Sensor Offline	None	<p>D: (Index) - (1) Network Type - Rnet Address - 1</p>
Associated Sensors																																																									
Index	Area	Network Type	Address	Lock Display	Version	Status	Error																																																		
1	Main ZS Sensor	Rnet	1	<input type="checkbox"/>	ZSPFH 1234567890v03.03.10	Sensor Configured	None																																																		
2	ZS Sensor 2	Unused	2	<input type="checkbox"/>		Sensor Offline	None																																																		
3	ZS Sensor 3	Unused	3	<input type="checkbox"/>		Sensor Offline	None																																																		
4	ZS Sensor 4	Unused	4	<input type="checkbox"/>		Sensor Offline	None																																																		
5	ZS Sensor 5	Unused	5	<input type="checkbox"/>		Sensor Offline	None																																																		
<p>ZS Zone Temp - Configure additional ZS temperature sensors used on the RTU Open.</p> <table border="1"> <thead> <tr> <th colspan="7">Sensor Configuration</th> </tr> <tr> <th colspan="7">Rnet Tag: Zone Temp (1)</th> </tr> <tr> <th>(Index)</th> <th>Area</th> <th>Use</th> <th>Raw Value</th> <th>Calibration</th> <th>Corrected Value</th> <th>Status</th> </tr> </thead> <tbody> <tr> <td>(1)</td> <td>Main ZS Sensor</td> <td><input checked="" type="checkbox"/></td> <td>77.53435</td> <td>0</td> <td>77.534</td> <td>None</td> </tr> <tr> <td>(2)</td> <td></td> <td><input type="checkbox"/></td> <td>0</td> <td>0</td> <td>-999.000</td> <td>No Comm</td> </tr> <tr> <td>(3)</td> <td></td> <td><input type="checkbox"/></td> <td>0</td> <td>0</td> <td>-999.000</td> <td>No Comm</td> </tr> <tr> <td>(4)</td> <td></td> <td><input type="checkbox"/></td> <td>0</td> <td>0</td> <td>-999.000</td> <td>No Comm</td> </tr> <tr> <td>(5)</td> <td></td> <td><input type="checkbox"/></td> <td>0</td> <td>0</td> <td>-999.000</td> <td>No Comm</td> </tr> </tbody> </table> <p>Combination Algorithm: Average Input Smoothing: Medium</p> <ul style="list-style-type: none"> Use - Check to include ZS sensors' value in the Combined Algorithm (Average is the default). Raw Value - Displays sensed temperature for each ZS temperature sensor's address Calibration - If needed, enter value to adjust the Corrected Value from the Raw Value, in order to calibrate an individual ZS sensor's sensed value. Combination Algorithm - Use Average, Maximum, or Minimum ZS temperature to calculate the Corrected Value for temperature control. 	Sensor Configuration							Rnet Tag: Zone Temp (1)							(Index)	Area	Use	Raw Value	Calibration	Corrected Value	Status	(1)	Main ZS Sensor	<input checked="" type="checkbox"/>	77.53435	0	77.534	None	(2)		<input type="checkbox"/>	0	0	-999.000	No Comm	(3)		<input type="checkbox"/>	0	0	-999.000	No Comm	(4)		<input type="checkbox"/>	0	0	-999.000	No Comm	(5)		<input type="checkbox"/>	0	0	-999.000	No Comm	<p>D: (Index) Area - (1) Main ZS Sensor Use - checked Calibration - 0 Combination Algorithm - Average Input Smoothing - Medium Show on Sensors - Calculated Value Display Resolution - 1 COV Increment - .1</p>
Sensor Configuration																																																									
Rnet Tag: Zone Temp (1)																																																									
(Index)	Area	Use	Raw Value	Calibration	Corrected Value	Status																																																			
(1)	Main ZS Sensor	<input checked="" type="checkbox"/>	77.53435	0	77.534	None																																																			
(2)		<input type="checkbox"/>	0	0	-999.000	No Comm																																																			
(3)		<input type="checkbox"/>	0	0	-999.000	No Comm																																																			
(4)		<input type="checkbox"/>	0	0	-999.000	No Comm																																																			
(5)		<input type="checkbox"/>	0	0	-999.000	No Comm																																																			

ZS Zone Humidity - Configure additional ZS humidity sensors used on the RTU Open.

Sensor Configuration

Rnet Tag: Zone Humidity (2)

(Index)	Area	Use	Raw Value	Calibration	Corrected Value	Status
(1)	Main ZS Sensor	<input type="checkbox"/>	32.772625	0	32.772	None
(2)		<input type="checkbox"/>	0	0	-999.000	No Comm
(3)		<input type="checkbox"/>	0	0	-999.000	No Comm
(4)		<input type="checkbox"/>	0	0	-999.000	No Comm
(5)		<input type="checkbox"/>	0	0	-999.000	No Comm

Combination Algorithm: **Maximum** Input Smoothing: **Medium**

- **Use** - Check to include ZS sensors' value in the **Combined Algorithm (Maximum** is the default).
- **Raw Value** - Displays sensed humidity for each ZS humidity sensor's address
- **Calibration** - If needed, enter value to adjust the **Corrected Value** from the **Raw Value**, in order to calibrate an individual ZS sensor's sensed value.
- **Combination Algorithm** - Use **Average, Maximum, or Minimum** ZS humidity to calculate the **Corrected Value** for humidity control.

D: **(Index) Area** - (1) Main ZS Sensor
Use - unchecked
Calibration - 0
Combination Algorithm - Maximum
Input Smoothing - Medium
Show on Sensors - Calculated Value
Display Resolution - 1
COV Increment - 1

ZS Zone CO2 - Configure additional ZS CO² sensors used on the RTU Open.

Sensor Configuration

Rnet Tag: Zone CO2 (3)

(Index)	Area	Use	Raw Value	Calibration	Corrected Value	Status
(1)	Main ZS Sensor	<input type="checkbox"/>	0	0	-999.000	Unsupported Read
(2)		<input type="checkbox"/>	0	0	-999.000	No Comm
(3)		<input type="checkbox"/>	0	0	-999.000	No Comm
(4)		<input type="checkbox"/>	0	0	-999.000	No Comm
(5)		<input type="checkbox"/>	0	0	-999.000	No Comm

Combination Algorithm: **Maximum** Input Smoothing: **Medium**

- **Use** - Check to include ZS sensors' value in the **Combined Algorithm (Maximum** is the default).
- **Raw Value** -Displays sensed CO² for each ZS CO² sensor's address
- **Calibration** - If needed, enter value to adjust the **Corrected Value** from the **Raw Value**, in order to calibrate an individual ZS sensor's sensed value.
- **Combination Algorithm** - Use **Average, Maximum, or Minimum** ZS CO² to calculate the **Corrected Value** for CO² control.

D: **(Index) Area** - (1) Main ZS Sensor
Use - unchecked
Calibration - 0
Combination Algorithm - Maximum
Input Smoothing - Medium
Show on Sensors - Calculated Value
Display Resolution - 1
COV Increment - 10

ZS model to show on graphic - Select the ZS model, from the drop-down list, that you want to display on the graphic.

D: ZS Pro-F model
R: None
ZS Pro model
ZS Base model
ZS Plus model
ZS Pro-F model

Sensor Calibration	
Space Temperature – The current space temperature.	D: °F/C
Space Temp Calibration – A calibration offset value to allow the local space temperature sensor to be adjusted to match a calibrated standard measuring the temperature in the same location.	D: 0Δ°F/C R: -9.9 to 10Δ°F (-5.5 to 5.5Δ°C)
Space RH – Displays the value read from a local RH sensor connected to one of the hardware input channels.	R: 0 to 100%
Space AQ – Displays the value read from a local CO ₂ sensor connected to one of the hardware input channels.	R: 0 to 5000ppm
Outdoor AQ – Displays the value read from an outdoor CO ₂ sensor connected to one of the hardware input channels.	0 to 5000ppm
Supply Air Temperature – Displays the current supply air temperature.	R: -56 to 245°F (-48.9 to 118.3°C)
Supply Air Temp Calibration – A calibration offset value to allow the supply air temperature sensor to be adjusted to match a calibrated standard measuring the temperature in the same location.	D: 0Δ°F/C R: -9.9 to 10Δ°F (-5.5 to 5.5Δ°C)
Outdoor Air Temperature – The current outdoor air temperature.	R: -56 to 245°F (-48.9 to 118.3°C)
Outdoor Air Temp Calibration – A calibration offset value allows the outdoor air temperature sensor to be adjusted to match a calibrated standard measuring the temperature in the same location.	D: 0°F/C R: -9.9 to 10Δ°F (-5.5 to 5.5Δ°C)

Setpoints

Navigation: i-Vu® / Field Assistant: **Properties > Control Program > Configuration > Setpoints**

Select a color band on the setpoint graph to see the current setpoints in the **Heating** and **Cooling** fields. The values in this graphic are Fahrenheit. See setpoint descriptions below.

NOTE This graphic is an example only. Your setpoints may differ.

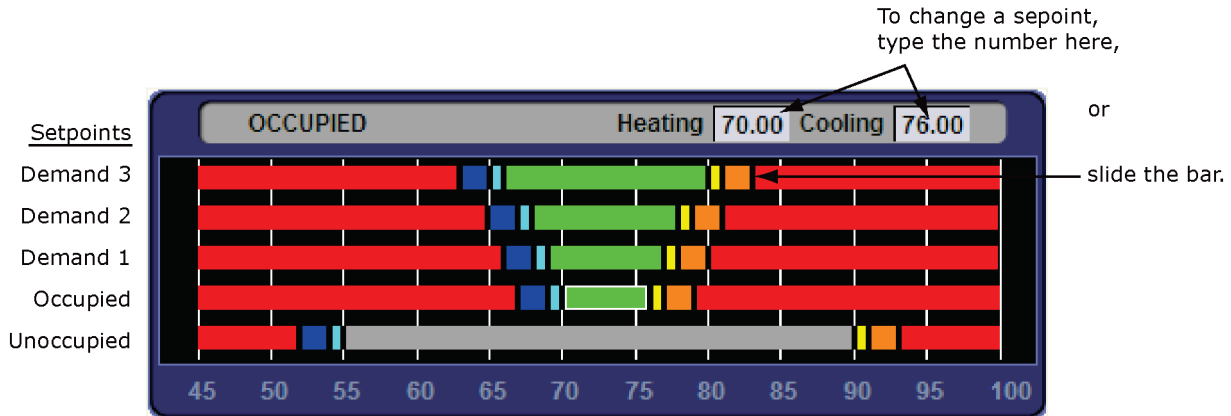

Occupied Setpoints

The occupied setpoints described below are the setpoints under normal operating conditions. The Demand Level 1–3 setpoints apply if demand limiting is used.

Demand limiting is a cost-saving strategy to reduce energy consumption. The strategy expands the occupied heating and cooling setpoints when the system reaches one of 3 levels of consumption. With the expanded setpoints, the equipment works less, thereby saving energy. By default, Demand Level 1 expands the occupied heating and cooling setpoints by 1Δ°F (Δ.5°C), Demand Level 2 by 2Δ°F (1.1Δ°C), and Demand Level 3 by 4Δ°F (2.2Δ°C). If the occupied heating or cooling setpoints change, the (effective) demand level setpoints automatically change by the same amount. See *Sequence of Operation* (page 44) for more information.

Point Name/Description	Default			
	Range: -40 to 245°F (-40 to 118.3°C)			
	Occupied	Demand Level		
1		2	3	
Occupied Heating – Green The heating setpoint the controller maintains while in occupied mode.	D: 70°F (21.1°C) 40 to 90°F R: (4.4 to 32.2°C)	69°F (20.5°C)	68°F (20°C)	66°F (18.9°C)
Occupied Cooling – Green The cooling setpoint the controller maintains while in occupied mode.	D: 76°F (24.4°C) 55 to 99°F R: (12.7 to 37.2°C)	77°F (25°C)	78°F (25.5°C)	80°F (26.6°C)

Point Name/Description	Default			
	Range: -40 to 245 °F (-40 to 118.3 °C)			
	Occupied	Demand Level		
1		2	3	
Occupied Heating 1 – Light Blue The space temperature must be less than the Occupied Heating 1 setpoint for the VVT Master to consider the zone a heating caller in a linked system. In a single-zone application, the heating requirement begins as soon as the space temperature falls below the Occupied Heating setpoint. We recommend that the Occupied Heating 1 value be set no less than 0.5Δ °F (.27Δ °C) below the Occupied Heating setpoint.	69 °F (20.5 °C)	68 °F (20 °C)	67 °F (19.4 °C)	65 °F (18.3 °C)
Occupied Heating 2 – Dark Blue The space temperature must be less than the Occupied Heating 2 setpoint to generate a low space temperature alarm. We recommend that this value be set no less than 0.5Δ °F (.27Δ °C) below the Occupied Heating 1 setpoint.	67 °F (19.4 °C)	66 °F (18.9 °C)	65 °F (18.3 °C)	63 °F (17.2 °C)
Occupied Cooling 1 – Yellow The space temperature must be greater than the Occupied Cooling 1 setpoint for the VVT Master to consider the zone a cooling caller in a linked system. In a single-zone application, the cooling requirement begins as soon as the space temperature exceeds the Occupied Cooling setpoint. We recommend that the Occupied Cooling 1 value be set no less than 0.5Δ °F (.27Δ °C) above the Occupied Cooling setpoint.	77 °F (25 °C)	78 °F (25.5 °C)	79 °F (26.1 °C)	81 °F (27.2 °C)
Occupied Cooling 2 – Orange The space temperature must be greater than the Occupied Cooling 2 setpoint to generate a high space temperature alarm. We recommend that this value be set no less than 0.5Δ °F (.27Δ °C) above the Occupied Cooling 1 setpoint.	79 °F (26.1 °C)	80 °F (26.6 °C)	81 °F (27.2 °C)	83 °F (28.3 °C)

Unoccupied Setpoints

Point Name/Description	Default/Range
Unoccupied Heating – Gray The heating setpoint the controller maintains while in unoccupied mode.	D: 55 °F (12.7 °C) R: 40 to 90 °F (4.4 to 32.2 °C)
Unoccupied Cooling – Gray The cooling setpoint the controller maintains while in unoccupied mode.	D: 90 °F (32.2 °C) R: 45 to 99 °F (7.2 to 37.2 °C)
Unoccupied Heating 1 – Light Blue The space temperature must be less than the Unoccupied Heating 1 setpoint for the VVT Master to consider the zone an unoccupied heating caller in a linked system. In a single-zone application, the unoccupied heating requirement begins as soon as the space temperature falls below the Unoccupied Heating setpoint. We recommend that the Unoccupied Heating 1 value be set no less than 0.5Δ °F (.27Δ °C) below the Unoccupied Heating setpoint.	D: 54 °F (12.2 °C) R: 40 to 90 °F (4.4 to 32.2 °C)

<p>Unoccupied Heating 2 – Dark Blue</p> <p>The space temperature must be less than the Unoccupied Heating 2 setpoint to generate an unoccupied low space temperature alarm. We recommend that this value be set no less than $0.5\Delta^{\circ}\text{F}$ ($.27\Delta^{\circ}\text{C}$) below the Unoccupied Heating 1 setpoint.</p>	<p>D: 52°F (11.1°C)</p> <p>R: 40 to 90°F (4.4 to 32.2°C)</p>
<p>Unoccupied Cooling 1 – Yellow</p> <p>The space temperature must be greater than the Unoccupied Cooling 1 setpoint for the VVT Master to consider the zone an unoccupied cooling caller in a linked system. In a single-zone application, the unoccupied cooling requirement begins as soon as the space temperature exceeds the Unoccupied Cooling setpoint. We recommend that the Unoccupied Cooling 1 value be set no less than $0.5\Delta^{\circ}\text{F}$ ($.27\Delta^{\circ}\text{C}$) above the Unoccupied Cooling setpoint.</p>	<p>D: 91°F (32.7°C)</p> <p>R: 45 to 99°F (7.2 to 37.2°C)</p>
<p>Unoccupied Cooling 2 – Orange</p> <p>The space temperature must be greater than the Unoccupied Cooling 2 setpoint to generate an unoccupied high space temperature alarm. We recommend that this value be set no less than $0.5\Delta^{\circ}\text{F}$ ($.27\Delta^{\circ}\text{C}$) above the Unoccupied Cooling 1 setpoint.</p>	<p>D: 93°F (33.9°C)</p> <p>R: 45 to 99°F (7.2 to 37.2°C)</p>
<p>Point Name/Description</p>	<p>Default/Range</p>
<p>Heating Capacity – Used for Optimal Start, this is the rate at which the zone temperature changes when the heating system runs at full capacity to maintain designed occupied heating setpoint.</p>	<p>D: 3Δ°F (1.6Δ°C)/hr</p> <p>R: 0 to 120Δ°F (0 to 66.6Δ°C)/hr</p>
<p>Heating Design Temp – The geographically-based outdoor air temperature at which the heating system must run constantly to maintain comfort. This information is available in ASHRAE publications and most design references.</p>	<p>D: 0°F/C</p> <p>R: -100 to 150°F (-73.3 to 65.5°C)</p>
<p>Cooling Capacity – Used for Learning Adaptive Optimal Start, this is the rate at which the zone temperature changes when cooling system runs at full capacity to maintain designed occupied cooling setpoint.</p>	<p>D: 3Δ°F (1.6Δ°C)/hr</p> <p>R: 0 to 140Δ°F (0 to 77.7Δ°C)/hr</p>
<p>Cooling Design Temp – The geographically-based outdoor air temperature at which the cooling system must run constantly to maintain comfort. This information is available in ASHRAE publications and most design references.</p>	<p>D: 100°F (37.7°C)</p> <p>R: -100 to 150°F (-73.3 to 65.5°C)</p>

Hysteresis – The desired difference between the temperature at which the zone color changes as the zone temperature departs from the acceptable range between the heating and cooling setpoints (green) into the Cooling 1 (yellow) or Heating 1 (light blue) and the temperature at which the zone color changes back to the acceptable range between the heating and cooling setpoints.

D: $.5\Delta^{\circ}\text{F}$ ($.27\Delta^{\circ}\text{C}$)

R: 0 to $120\Delta^{\circ}\text{F}$
(0 to $66.6\Delta^{\circ}\text{C}$)

For example, the following graph shows the zone color that results as the zone temperature departs from and returns to the acceptable range in a zone with the following settings:

- Color Change Hysteresis = $.5\Delta^{\circ}\text{F}$ ($.27\Delta^{\circ}\text{C}$) (applies as the temperature returns to the acceptable range)
- Occupied cooling setpoint = 76°F (24.4°C)
- Occupied heating setpoint = 70°F (21.1°C)

NOTE The values in the graph below are Fahrenheit.

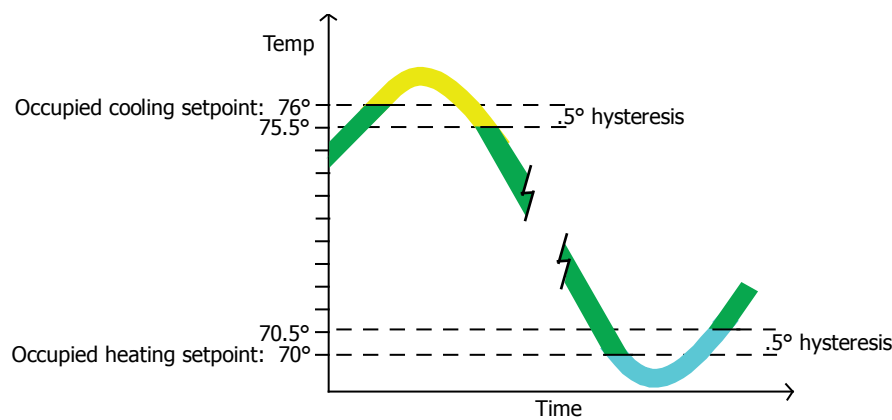

Learning Adaptive Optimal Start

Red	DkBlue	LtBlue	Green or SpGrn	Yellow	Orange	Red
0.1900	0.1300	0.0600	0.0600	0.0600	0.1300	0.1900

When the Learning Adaptive Optimal Start algorithm runs, the learned heating capacity or learned cooling capacity values are adjusted based on the color that is achieved when occupancy begins. The adjustment amounts for each color are displayed in the thermographic color fields (shown above with English default values).

Point Name/Description	Range	
	English	Metric
Red – The amount the zone’s learned heating capacity is adjusted when the Learning Adaptive Optimal Start algorithm runs, when the zone’s thermographic color at occupancy is red.	D: 0.1900 R: 0 to 1	.1055
DkBlue – The amount the zone’s learned heating capacity is adjusted when the Learning Adaptive Optimal Start algorithm runs, when the zone’s thermographic color at occupancy is dark blue.	D: 0.1300 R: 0 to 1	.0722
LtBlue – The amount the zone’s learned heating capacity is adjusted when the Learning Adaptive Optimal Start algorithm runs, when the zone’s thermographic color at occupancy is light blue.	D: 0.0600 R: 0 to 1	.0333

Point Name/Description	Range	
	English	Metric
Green – The amount the zone’s learned heating capacity is adjusted when the Learning Adaptive Optimal Start algorithm runs, when the zone’s thermographic color at occupancy is green.	D: 0.0600 R: 0 to 1	.0333
SpGrn – The amount the zone’s learned cooling capacity is adjusted when the Learning Adaptive Optimal Start algorithm runs, when the zone’s thermographic color at occupancy is green.	D: 0.0600 R: 0 to 1	.0333
Yellow – The amount the zone’s learned cooling capacity is adjusted when the Learning Adaptive Optimal Start algorithm runs, when the zone’s thermographic color at occupancy is yellow.	D: 0.0600 R: 0 to 1	.0333
Orange – The amount the zone’s learned cooling capacity is adjusted when the Learning Adaptive Optimal Start algorithm runs, when the zone’s thermographic color at occupancy is orange.	D: 0.1300 R: 0 to 1	.0722
Red – The amount the zone’s learned cooling capacity is adjusted when the Learning Adaptive Optimal Start algorithm runs, when the zone’s thermographic color at occupancy is red.	D: 0.1900 R: 0 to 1	.1055
Heating – (Occupied or Unoccupied, depending on mode) The current programmed Heating setpoint adjusted by any offset that may be in effect.	R: 0 to 120°F (-17.7 to 48.9°C)	
Cooling – (Occupied or Unoccupied, depending on mode) The current programmed Cooling setpoint adjusted by any offset that may be in effect.	R: 0 to 120°F (-17.7 to 48.9°C)	
Learned cooling capacity – The cooling capacity learned by Learning Adaptive Optimal Start that is required to bring the space temperature down to the occupied cooling setpoint prior to the occupied time.	R: °F/C	
Learned heating capacity – The heating capacity learned by Learning Adaptive Optimal Start that is required to bring the space temperature up to the occupied heating setpoint prior to the occupied time.	R: °F/C	
Min Setpoint Separation – Minimum separation that must be maintained between the heating and cooling setpoints.	R: °F/C	
Optimal Start – The number of hours prior to occupancy, at which the Optimal Start function may begin to adjust the effective setpoints to achieve the occupied setpoints by the time scheduled occupancy begins. Enter 0 to disable Optimal Start. NOTE Optimal Start is automatically disabled when occupancy is controlled by a network write to the controller's keypad_ovrde variable. (Display name: BAS On/Off , in Properties > Control Program > Maintenance > Occupancy > BAS On/Off , or when utilizing Airside Linkage or the System Occupancy Network Variable .)	D: 4 hr R: 0 to 4 hrs	

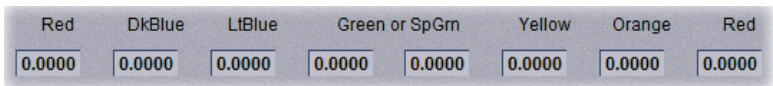
Point Name/Description	Range	
	English	Metric
<p>Optimal Start Type – The method used to change from unoccupied to occupied setpoint.</p> <p>Options: None – Unit will not change to occupied setpoint until the scheduled time or the unit goes into an occupied mode. Setpoints do not ramp, but change immediately from unoccupied to occupied values. Temp Compensated – Unit changes to occupied setpoints at a variable time prior to the occupied time, which is calculated by the current difference between space temperature and the appropriate heating or cooling setpoint. At that time, the setpoints do not ramp, but change immediately from unoccupied to occupied values. Learning Adaptive Start – Unit gradually changes to occupied setpoints by adjusting the unoccupied setpoints over a specified period of time to achieve the occupied setpoint by the time scheduled occupancy begins.</p> 	D: Temperature Compensated None R: Temperature Compensated Learning Adaptive	
<p>Heat Start K factor (min/deg) – If Optimal Start Type is Temp Compensated, this is the time in minutes per degree that the equipment starts before the occupied period when the space temperature is below the occupied heating setpoint (including any setpoint offset).</p>	D: 15.00 R: 0 to 99	
<p>Cool Start K factor (min/deg) – If Optimal Start Type is Temp Compensated, this is the time in minutes per degree that the equipment starts before the occupied period when the space temperature is above the occupied cooling setpoint (including any setpoint offset).</p>	D: 15.00 R: 0 to 99	
<p>Occ Relative Humidity Setpoint – The percentage of relative humidity in the space during occupancy that will energize BO - 6 (Humidi-MiZer™).</p>	D: 60%rh R: 0 to Unoccupied RH Control Setpoint	
<p>Unocc Relative Humidity Setpoint – The percentage of relative humidity in the space during the unoccupied time period that starts the unit and energizes BO - 6 (Humidi-MiZer™).</p>	D: 95% R: 30 to 100%	
<p>DCV Max Ctrl Setpoint – The design difference between indoor and outdoor CO2 levels.</p>	D: 650ppm R: 0 to 9999 ppm	
<p>Power Exhaust Setpoint - The outside air damper position at which the controller energizes the Power Exhaust relay. Configuration >Service Configuration > Economizer Exists must be set to Yes, and Configuration >Service Configuration > Continuous Occupied Exhaust must be set to No.</p>	D: 50% Open R: 20 to 90% Open	

Alarm Configuration

Navigation: i-Vu® / Field Assistant: **Properties > Control Program > Configuration > Alarm Configuration**

Point Name/Description	Default/Range
Space Temperature Alarm	
Occupied Alarm Hysteresis – This value is added to the occupied high effective setpoint and subtracted from the occupied low effective setpoint to establish the occupied high and low limits that the space temperature must exceed before an occupied SPT alarm is generated. The alarm returns to normal when the space temperature drops below the high effective setpoint or rises above the low effective setpoint.	D: 5Δ °F (2.7Δ °C) R: 0 to 20Δ °F (0 to 11.1Δ °C)
Alarm Delay (min/deg) – Determines the amount of delay before an occupied space temperature alarm is generated when the controller transitions to the occupied mode. The delay time equals this value multiplied by the difference between the sensor temperature and occupied alarm setpoint plus 15 minutes.	D: 10 minutes R: 0 to 60 minutes
Unoccupied Low SPT Alarm Limit – The value that the space temperature must drop below to generate a Space Temperature Alarm in the unoccupied mode. There is a fixed hysteresis of 1Δ °F (.5Δ °C) for return to normal.	D: 45 °F (7.2 °C) R: 35 to 90 °F (1.6 to 32.2 °C)
Unoccupied High SPT Alarm Limit – The value that the space temperature must exceed to generate a Space Temperature Alarm in the unoccupied mode. There is a fixed hysteresis of 1Δ °F (.5Δ °C) for return to normal.	D: 95 °F (35 °C) R: 45 to 100 °F (7.2 to 37.7 °C)
Supply Air Temperature Alarm	
Low SAT Alarm Limit – The value that the supply air temperature must drop below to generate a Supply Air Temp Alarm . There is a fixed hysteresis of 1Δ °F (.5Δ °C) for return to normal.	D: 38 °F (3.3 °C) R: 15 to 90 °F (-9.4 to 32.2 °C)
High SAT Alarm Limit – The value that the supply air temperature must exceed to generate a Supply Air Temp Alarm . There is a fixed hysteresis of 1Δ °F (.5Δ °C) for return to normal.	D: 160 °F (71.1 °C) R: 90 to 175 °F (32.2 to 79.4 °C)
Space Humidity Alarm	
Occupied High RH Alarm Limit – The value that the relative humidity sensor must exceed to generate a Space Humidity Alarm in the occupied mode if RH Control is set to Enable . There is a fixed hysteresis of 5%rh for return to normal.	D: 70%rh R: 0 to 100%rh
Alarm Delay (min/%RH) – Determines the amount of delay before an occupied RH alarm is generated when the controller transitions to the occupied mode. The delay time equals this value multiplied by the difference between the sensor RH value and the occupied RH setpoint plus 15 minutes.	D: 5 minutes R: 0 to 30 minutes
Unocc High RH Alarm Limit – The value that the relative humidity sensor must exceed to generate a Space Relative Humidity alarm in the unoccupied mode if RH Control is set to Enable . There is a fixed hysteresis of 5%rh for return to normal.	D: 100%rh R: 0 to 100%rh
Low RH Alarm Limit – The value that the relative humidity sensor must drop below to generate a Space Humidity Alarm in either the unoccupied or occupied modes if RH Control is set to Enable . There is a fixed hysteresis of 5%rh for return to normal.	D: 30%rh R: 0 to 100%rh

Point Name/Description	Default/Range
IAQ/Ventilation Alarm	
Occupied High CO2 Alarm Limit – The value that the CO ₂ sensor must exceed to generate an IAQ Alarm in the occupied mode. There is a fixed hysteresis of 100ppm for return to normal. Requires a valid Indoor Air Quality CO2 sensor value and IAQ Control is set to Enable .	D: 1200ppm R: 0 to 9999 ppm

Alarms Displayed on ZS or SPT Sensor	Range
You can individually select items below to show the alarm indicator on the ZS or SPT sensor.	
Fire / Smoke Shutdown – If set to display, shows the alarm indicator on the communicating zone sensors with display, if the fire shutdown circuit trips.	D: Ignore R: Ignore/Display
Stuck Gas Valve Alarm – If set to display, shows the alarm indicator on the communicating zone sensors with display, if the fire shutdown circuit trips.	D: Ignore R: Ignore/Display
Compressor Safety / Chain Alarm – If set to display, shows the alarm indicator on the communicating zone sensors with display, if the safety chain circuit trips.	D: Ignore R: Ignore/Display
Space Temperature High / Low Alarm – If set to display, shows the alarm indicator on the communicating zone sensors with display, if the space temperature sensor exceeds the high or low alarm limit.	D: Ignore R: Ignore/Display
Space Indoor Air CO2 High Alarm – If set to display, shows the alarm indicator on the communicating zone sensors with display, if the occupied CO ₂ level exceeds the configured high alarm limit.	D: Ignore R: Ignore/Display
Space Relative Humidity High Alarm – If set to display, shows the alarm indicator on the communicating zone sensors with display, if a valid space relative humidity sensor exceeds the configured alarm limits.	D: Ignore R: Ignore/Display
Supply Fan Failure Alarm – If set to display, shows the alarm indicator on the communicating zone sensors with display, if the supply fan is not operating when commanded on.	D: Ignore R: Ignore/Display
Supply Air Temperature Low or High Alarm – If set to display, shows the alarm indicator on the communicating zone sensors with display, if the supply air temperature exceeds the configured alarm limits.	D: Ignore R: Ignore/Display
Maintenance Displayed on ZS Sensor	
Sensor Faults – If set to display, shows the Maintenance or Fault indicator on the communicating zone sensors with display, if a valid space temperature sensor to sensor value is not available to the controller.	D: Ignore R: Ignore/Display

Alarms Displayed on ZS or SPT Sensor	Range
You can individually select items below to show the alarm indicator on the ZS or SPT sensor.	
Filter Dirty Alarm/Maint – If set to display, shows the Maintenance or Fault indicator on the communicating zone sensors with display, if filter runtime exceeds the value of the Filter Service Alarm Timer or in response to a filter status switch binary input.	D: Display R: Ignore/Display
Airside Linkage Status Alarm – If set to display, shows the Maintenance or Fault indicator on the communicating zone sensors with display, if Linkage has failed in a zoned system using Linkage.	D: Ignore R: Ignore/Display
Misconfiguration - Switch/Analog Inputs – If set to display, shows the Maintenance or Fault indicator on the communicating zone sensors with display. Indicates if a duplicate configuration exists for two or more binary input (3, 5, 8, or 9) functions, OR if a duplicate configuration exists at the analog Input 1 and 2 functions.	D: Ignore R: Ignore/Display
Compressor 1 Runtime Alarm – If set to display, shows the Maintenance or Fault indicator on the communicating zone sensors with display, if the Compressor 1 Runtime exceeds the value of the Compressor 1 Service Alarm Timer .	D: Ignore R: Ignore/Display
Compressor 2 Runtime Alarm – If set to display, shows the Maintenance or Fault indicator on the communicating zone sensors with display, if the Compressor 2 Runtime exceeds the value of the Compressor 2 Service Alarm Timer .	D: Ignore R: Ignore/Display
Supply Fan Hand Fault – If set to display, shows the Maintenance or Fault indicator on the communicating zone sensors with display, if the supply fan is operating when commanded off.	D: Ignore R: Ignore/Display
Supply Fan Runtime Alarm – If set to display, shows the Maintenance or Fault indicator on the communicating zone sensors with display, if the supply fan runtime exceeds the value of the Supply Fan Service Alarm Timer .	D: Ignore R: Ignore/Display

Service Configuration

Navigation: i-Vu® / Field Assistant: **Properties > Control Program > Configuration > Service Configuration**

Point Name/Description	Range
<p>Unit Type – The type of equipment that the RTU Open is controlling.</p> <p>Options: Heat/Cool – Standard rooftop air handling unit. LC Weather Expert™ – A special factory-supplied 3-stage cooling unit HP O/B Ctrl – Heat Pump application, uses reversing valve output to control heating and cooling. HP Y1/W1 Ctrl – Carrier Heat Pump application only.</p>	D: Heat/Cool R: Heat/Cool LC WeatherExpert™ HP O/B Ctrl HP Y1/W1 Ctrl
<p>Compressor Stages – The number of mechanical cooling stages.</p> <p>Not displayed if Unit Type is set to LC WeatherExpert™.</p>	D: One Stage R: One Stage Two Stages

Point Name/Description	Range
<p>Face Split Coil – Applies only to 2-stage cooling unit with variable speed fan control, this defines the type of cooling coil installed in the unit. The controller uses it to estimate the temperature of the air leaving the active portion of the cooling coil during part-load operation.</p> <p>Not displayed if Unit Type is set to LC WeatherExpert™.</p>	<p>D: Yes</p> <p>R: No/Yes</p>
<p>Economizer Exists – Set to Yes to enable economizer control for units equipped with an economizer damper.</p>	<p>D: No</p> <p>R: No/Yes</p>
<p>Fan Control – The type of fan control used on this unit.</p> <p>Automatically set to Variable Speed if Unit Type is set to LC WeatherExpert™.</p>	<p>D: Single Speed</p> <p>R: Single Speed Two Speed Variable Speed</p>
<p>VFD Input – Defines the electrical control signal used by the Variable Frequency Drive's (VFD) input. Applies to Variable Speed fan control only.</p>	<p>D: 2-10 Vdc</p> <p>R: 0-10 Vdc 2-10 Vdc</p>
<p>Max VFD Output – The maximum output signal the control supplies to the VFD as a percentage of its range. The balancer can set this to adjust the unit's maximum airflow. Applies to Variable Speed fan control only.</p>	<p>D: 100%</p> <p>R: 33% to 100%</p>
<p>Min VFD Output – The minimum output signal the control supplies to the VFD as a percentage of its range. The balancer can set this to adjust the unit's minimum airflow. Applies to Variable Speed fan control only.</p>	<p>D: 40%</p> <p>R: 33% to 100%</p>
<p>Dehum Min VFD Output – The minimum output signal supplied by the control during dehumidification as a percentage of its range. Applies only to Variable Speed fan control.</p>	<p>D: 60%</p> <p>R: 50% to 100%</p>
<p>Stage 1 SAT Stpt – The VFD Supply Air Setpoint during stage 1 cooling.</p> <p>Must be at least 4 °F (2.2 °C) greater than Minimum Cooling SAT.</p>	<p>D: 57 °F (13.9 °C)</p> <p>R: 45 to 75 °F (7.2 to 23.9 °C)</p>
<p>Stage 2 SAT Stpt – The VFD Supply Air Setpoint during stage 2 cooling.</p> <p>Must be at least 4 °F (2.2 °C) greater than Minimum Cooling SAT.</p>	<p>D: 57 °F (13.9 °C)</p> <p>R: 45 to 75 °F (7.2 to 23.9 °C)</p>
<p>Stage 3 SAT Stpt – The VFD Supply Air Setpoint during stage 3 cooling.</p> <p>Must be at least 4 °F (2.2 °C) greater than Minimum Cooling SAT.</p>	<p>D: 56 °F (13.3 °C)</p> <p>R: 45 to 75 °F (7.2 to 23.9 °C)</p>
<p>Reversing Valve Output – The type of reversing valve this unit uses.</p>	<p>D: 0</p> <p>R: 0/B</p>
<p>Heat Type – The type of heating used by the unit.</p>	<p>D: Electric</p> <p>R: Electric/Gas</p>
<p>Number of Heat Stages – The number heat stages.</p>	<p>D: 2</p> <p>R: 1 / 2 /0 (no heating)</p>
<p>Continuous Occupied Exhaust – Configures the exhaust fan control strategy (BO-8). If Yes, the power exhaust runs continuously in occupied mode and is off in unoccupied mode. If No, the power exhaust is controlled by the Power Exhaust Setpoint.</p>	<p>D: No</p> <p>R: No/Yes</p>

Point Name/Description	Range
RH Control – Enables dehumidification control if an RH sensor or humidistat is available and the unit has the Humidi-MiZer™ dehumidification option installed.	D: Disable R: Disable/Enable
DCV Control – Enables demand controlled ventilation (DCV) if valid CO ₂ sensor value is available and the unit has an economizer installed.	D: Disable R: Disable/Enable
Indoor CO₂ Sensor Value @min (ma) – The CO ₂ value that corresponds to a 4mA input at the appropriate input channel.	D: 0 ppm R: 0 to 9999 ppm
Indoor CO₂ Sensor Value @max (ma) – The CO ₂ value that corresponds to a 20mA input at the appropriate input channel.	D: 2000 ppm R: 0 to 9999 ppm
Outdoor CO₂ Sensor Value @min (ma) – The CO ₂ value that corresponds to a 4 mA input at the appropriate input channel.	D: 0 ppm R: 0 to 9999 ppm
Outdoor CO₂ Sensor Value @max (ma) – The CO ₂ value that corresponds to a 20 mA input at the appropriate input channel.	D: 2000 ppm R: 0 to 9999 ppm
System Space Temperature – The network space temperature value that the controller is using for control (if applicable).	D: -999.00° R: N/A
System Space RH – The network relative humidity value that the controller is using for control (if applicable).	D: -999.00% R: N/A
System Space AQ – The network indoor air quality (CO ₂) value that the controller is using for control (if applicable).	D: -999.00 ppm R: N/A
System Cool Demand Level – The system cool demand level being received over the network.	D: 0.00 R: 0 to 3
System Heat Demand Level – The system heat demand level being received over the network.	D: 0.00 R: 0 to 3
System Outdoor Air Temperature – Allows the outdoor air temperature value to be network readable when enabled. Requires controller be equipped with an outdoor air temperature sensor.	D: -999.00 ppm R: N/A
System Outdoor AQ – Allows network-readable OAQ value for calculating the differential OAQ CO ₂ levels and IAQ CO ₂ levels to drive the IAQ control.	D: -999.0° R: N/A
System Fire / Smoke – Enable to stop automatic control so you can test the controller's outputs. Automatically resets to Disable after 1 hour.	D: Off R: Off/On

Point Name/Description	Default/Range
Service Test – Enable to stop automatic control so you can test the controller's outputs. Automatically resets to Disable after 1 hour.	D: Disable R: Disable/Enable

Fan Test – Enable to test the controller's fan operation. Operates fan at low speed if the fan type is set to Two Speed. Resets to Disable when complete. Service Test must be set to Enable .	D: Disable R: Disable/Enable
High Speed Fan Test – Enable to test the unit's high speed fan operation. Operates fan at high speed if Fan Control is set to Two Speed . Resets to Disable when complete. Service Test must be set to Enable .	D: Disable R: Disable/Enable
Compressor 1 Test – Enable to test the controller's compressor 1 output. Service Test must be set to Enable .	D: Disable R: Disable/Enable
Compressor 2 Test – Enable to test the controller's compressor 2 output. Service Test must be set to Enable .	D: Disable R: Disable/Enable
Heat 1 Test – Enable to test the controller's heat 1 output. Service Test must be set to Enable .	D: Disable R: Disable/Enable
Heat 2 Test – Enable to test the controller's heat 2 output. Service Test must be set to Enable .	D: Disable R: Disable/Enable
Reversing Valve Test – Enable to test the controller's reversing valve output. Service Test must be set to Enable .	D: Disable R: Disable/Enable
Dehumidification Test – Enable to test the controller's Humidi-MiZer™ output. Service Test must be set to Enable .	D: Disable R: Disable/Enable
Power Exhaust Test – Enable to test the controller's exhaust fan output. Service Test must be set to Enable .	D: Disable R: Disable/Enable
Economizer Test – Set to a value between 0 and 100% to test the controller's economizer output. Service Test must be set to Enable .	D: 0% Open R: 0 to 100% Open
VFD Speed Test – Set to a value between 0 and 100% to test the controller's variable speed fan output. Service Test and Fan Test both must be set to Enable .	D: 0% R: 0 to 100%

Maintenance

Navigation: i-Vu® / Field Assistant: **Properties > Control Program > Maintenance**

Point Name/Description	Default/Range
Unit	
Occupancy Status – The controller's occupancy status as determined by a network schedule, a local schedule, or a timed override.	R: Unoccupied/Occupied
Indicates the current status of the system: Temp Compensated Start Learning Adaptive Start	R: Inactive/Active

Point Name/Description	Default/Range
Pre-Occ Purge – Indicates if the pre-occupancy purge cycle is active.	R: Inactive/Active
Space Temp Source – The source of the controlling space temperature value. Options: Sensor Failure – No valid space temperature or sensor status = failed. SPT Sensor – An SPT sensor is connected to the controller's Rnet port. T55/56 – A T55, T56, or T59 sensor is connected to the controller's I/O terminals. Network – A network temperature sensor is bound to the controller's space temperature AV. Airside Linkage – The space temperature from a linked terminal. Locked Value – The controller's space temperature input has been manually locked at a value. ZS Sensor – A ZS sensor is connected to the controller's Rnet port.	R: Sensor Failure SPT Sensor T55/T56 Network Airside Linkage Locked Value ZS Sensor
Setpoint Adjustment – Indicates the amount of offset applied if you configured the space sensor as a type of T56. Set the display value range in Setpoint Adjustment Range .	R: °F/C
Effective Heat Setpoint – The current heating setpoint. May include offsets from configured occupied/unoccupied setpoints resulting from Optimal Start to Demand Limit .	R: °F/C
Effective Cool Setpoint – The current cooling setpoint. May include offsets from configured occupied/unoccupied setpoints resulting from Optimal Start to Demand Limit .	R: °F/C
Relative Humidity Source – The source of the relative humidity value.	R: N/A Local Network Linkage Locked Value Linkage & Local ZS Sensor Linkage & ZS Sensor
IAQ Source – The source of the indoor air quality value.	R: N/A Local Network Linkage Locked Value Linkage & Local ZS Sensor Linkage & ZS Sensor
OAQ Source – The source of the outdoor air quality value.	R: N/A Local Network Linkage Locked Value Linkage & Local
Outdoor Air Temperature Source – The source of the outdoor air temperature.	R: N/A Local Network Linkage Locked Value
System Cooling Demand Level – The demand limit used by the control in cooling mode.	R: 0 to 3

Point Name/Description	Default/Range
System Heating Demand Level – The demand level used by the control in heating mode.	R: 0 to 3
System Status – The System Status Variable for Title 24.	R: OA Econ unsuitable Free Cooling Avail Economizer Enabled Compressor Enabled Heating Enabled MA Low Limit Active
Safety Chain Feedback - Indicates a completed circuit from J1, 1 to J1, 9. This circuit is typically used for safety devices that immediately stop unit operation when tripped.	R: Off/Run Enabled
Fire Shutdown – Shutdown indicates that a fire shutdown is in effect.	R: Run Enabled/ Shutdown
Compressor Safety Status – Trouble indicates that the compressor safety device has tripped.	R: Normal/Trouble
Calculated Min Econ Pos – Indicates the minimum position value that the economizer control is using.	R: 0 to 100%
Calculated PE Setpoint – Indicates the setpoint value the power exhaust fan control is using. This value is automatically calculated from the configured setpoint when you use a 2-speed or variable speed fan.	R: 0 to 100%
Active Compressor Stages – The number of compressor stages currently operating.	R: 0 to 2
Active Heat Stages – The number of heating stages currently operating.	R: 0 to 2
Fan Control – The type of fan control used for this RTU Open.	R: Single Speed Two Speed Variable Speed
Enthalpy Status – The enthalpy status determined by an enthalpy switch.	R: High/Low
Enthalpy (BACnet) – The enthalpy status the controller receives through BACnet communication.	R: High (0) / Low (1)
Humidistat Input Status – The humidity status determined by a humidistat.	R: High/Low
Filter Status – Displays the current filter condition to the filter input if that option is configured.	R: Clean/Dirty
Door Contact Switch – Displays the state of the door contact switch if that option is configured.	R: Off/On
IGC Override – Displays the state of the IGC Override input status. An Active state indicates a flame is present.	R: Off/Active
Reset Supply Fan Runtime Alarm – Set to Clear to reset Supply Fan Runtime to 0.	D: Run R: Run/Clear
Reset Comp 1 Runtime Alarm – Set to Clear to reset Compressor 1 Runtime to 0.	D: Run R: Run/Clear
Reset Comp 2 Runtime Alarm – Set to Clear to reset Compressor 2 Runtime to 0.	D: Run R: Run/Clear
Reset Filter Alarm – Set to On to reset Filter Runtime to 0.	D: Run R: Run/Clear

Point Name/Description	Default/Range
Occupancy	
<p>BAS On/Off – Determines the occupancy state of the controller and can be set over the network by another device or third party BAS.</p> <p>Options:</p> <p>Inactive – Occupancy is determined by a configured schedule. Occupied – The controller is always in the occupied mode. Unoccupied – The controller is always in the unoccupied mode.</p> <p>NOTE If BAS On/Off is set to either Unoccupied or Occupied, the Optimal Start routine is automatically disabled.</p>	<p>D: Inactive</p> <p>R: Inactive Occupied Unoccupied</p>
Pushbutton Override – Active indicates if a user pushed the sensor's override button to override the occupancy state.	R: Off/Active
Occupancy Contact – ON indicates an external contact is controlling the occupancy state.	R: Off/On
Override Time Remaining – The amount of time remaining in an override period.	R: 0 to 240 minutes
Schedules – The controller's occupancy status based on the local schedule.	R: Unoccupied/Occupied
Runtime	
Supply Fan Runtime – The total number of hours that the supply fan relay has been energized since the runtime was last reset to 0 using Reset Supply Fan Runtime Alarm .	R: __ hr
Compressor 1 Runtime – The total number of hours that the Compressor 1 relay has been energized since the runtime was last reset 0 using Reset Comp 1 Runtime Alarm .	R: __ hr
Compressor 2 Runtime – The total number of hours that the Compressor 2 relay has been energized since the runtime was last reset using Reset Comp 2 Runtime Alarm .	R: __ hr
Filter Runtime – The total number of hours that the unit has been operating since the runtime was last reset to 0 using Reset Filter Runtime Alarm .	R: __ hr

Performance

Navigation: i-Vu® / Field Assistant: **Properties > Control Program > Performance**

Point Name/Description	Range
Current Performance Data	
Equipment Runtime – RTU Open's hours of operation since the last reset of Performance Data.	R: __ hr

Point Name/Description	Range
Economizer Utilization – Percentage of Equipment Runtime hours that are above the active Economizer time since the last reset of Performance Data .	R: 0 to 100%
DCV Utilization – Percentage of Equipment Runtime hours that are above the active DCV time since the last reset of Performance Data .	R: 0 to 100%
Unocc Free Cool Utilization – Percentage of Equipment Runtime hours that are above active Unoccupied Free Cooling since the last reset of Performance Data .	R: 0 to 100%
Part Load Cooling Utilization – Percentage of Equipment Runtime hours that are above Cooling time in which less than the maximum configured cooling stages were active since the last reset of Performance Data .	R: 0 to 100%
Full Load Cooling Utilization – Percentage of Equipment Runtime hours that are above Cooling time in which all of the configured cooling stages were active since the last reset of Performance Data .	R: 0 to 100%
Heating Utilization – Percentage of Equipment Runtime hours that are above active Heating time since the last reset of Performance Data .	R: 0 to 100%
Recorded High OAT – Maximum recorded OAT since the last reset of Performance Data .	R: __ °F/C
Recorded Low OAT – Minimum recorded OAT since the last reset of Performance Data .	R: __ °F/C
Performance Data – Resets all the Current Performance Data properties to zero and shifts all the Current Performance Data into the appropriate Historical Performance Data fields below.	D: Collect R: Collect/Reset
Historical Performance Data	
Save Performance Data Daily – If enabled, automatically moves Current Performance Data to Historical Performance Data when resetting the Current Performance Data every night at midnight.	D: Disable R: Disable/Enable
Equipment Runtime – RTU Open's hours of operation which occurred in the previous period that was prior to the last Performance Data reset.	R: __ hr
Economizer Utilization – Percentage of Equipment Runtime hours, above active Economizer time, which occurred in the previous period that was prior to the last Performance Data reset.	R: 0 to 100%
DCV Utilization – Percentage of Equipment Runtime hours that the DCV was active in the previous period that was prior to the last Performance Data reset.	R: 0 to 100%
Unocc Free Cool Utilization – Percentage of Equipment Runtime hours that the Unoccupied Free Cooling was active in the previous period that was prior to the last Performance Data reset.	R: 0 to 100%
Part Load Cooling Utilization – Percentage of Equipment Runtime hours that the Cooling, with less than the maximum configured number of cooling stages, was active in the previous period that was prior to the last Performance Data reset.	R: 0 to 100%
Full Load Cooling Utilization – Percentage of Equipment Runtime hours that the Cooling, with all of the configured number of cooling stages, was active in the previous period that was prior to the last Performance Data reset.	R: 0 to 100%

Point Name/Description	Range
Heating Utilization – Percentage of Equipment Runtime hours that the Heating was active in the previous period that was prior to the last Performance Data reset.	R: 0 to 100%
Previous High OAT – Maximum recorded OAT in the previous period that was prior to the last Performance Data reset.	R: __ °F/C
Previous Low OAT – Minimum recorded OAT in the previous period that was prior to the last Performance Data reset.	R: __ °F/C

Alarms

Navigation: i-Vu® / Field Assistant: **Properties > Control Program > Alarms**

Point Name/Description	Range
Safety Chain – Indicates if the safety chain circuit trips.	R: Normal/Alarm
Fire / Smoke Shutdown – Indicates if the fire shutdown circuit trips.	R: Normal/Alarm
Gas Valve – Indicates that the integrated gas valve is stuck open and a flame is still present while heat has been commanded off.	R: Normal/Alarm
Compressor Status – Indicates if the compressor safety circuit trips.	R: Normal/Alarm
Space Temperature – Indicates if the space temperature sensor exceeds the high or low alarm limit.	R: Normal/Alarm
Alarming Temperature – Indicates the space temperature value that caused the space temperature alarm. Visible only in an alarm condition.	R: The sensor's range
Alarm Limit Exceeded – The alarm limit that the alarming space temperature sensor exceeded. Visible only in an alarm condition.	R: The configured limit
SPT Sensor – Indicates if the SPT communicating zone temperature sensor is no longer communicating.	R: Normal/Alarm
Space Temp Sensor – Indicates that a valid space temperature sensor or sensor value is no longer available to the controller.	R: Normal/Alarm
Supply Air Temperature – Indicates if the supply air temperature exceeds the configured alarm limits.	R: Normal/Alarm
Supply Air Temp Sensor – Indicates if the supply air temperature sensor fails.	R: Normal/Alarm
Supply Fan Failure – The supply fan is not operating when commanded on.	R: Normal/Alarm
Supply Fan in Hand – The supply fan is operating when commanded off.	R: Normal/Alarm
Indoor Air Quality – Indicates if the occupied CO ₂ level exceeds the configured high alarm limit.	R: Normal/Alarm
Indoor Air Quality Sensor – Indicates that a valid indoor air quality sensor or sensor value is no longer available to the controller.	R: Normal/Alarm

Point Name/Description	Range
Space Relative Humidity – Indicates that a valid space relative humidity sensor exceeds the configured alarm limits.	R: Normal/Alarm
Space Relative Humidity Sensor – Indicates that a valid space relative humidity sensor or sensor value is no longer available to the controller.	R: Normal/Alarm
Filter – Indicates a dirty filter condition when the filter runtime exceeds the value of the Filter Service Alarm Timer or in response to a filter status switch binary input.	R: Clean/Dirty
Local OAT Sensor – Indicates the local outdoor air temperature sensor connected to this equipment fails.	R: Normal/Alarm
Outdoor Air Temp Sensor – Indicates if the controller is no longer receiving a valid outdoor air temperature value either through the network or from a local sensor.	R: Normal/Alarm
Economizer Operation – Indicates the state of the economizer's operation and if an economizer Operation Fault has been detected.	R: Normal/Alarm
Economizer – If Economizer Operation has been set to Alarm , the Economizer Fault Detection Diagnostic Result displays.	R: Normal Failed to Fully Open Failed to Open Failed to Close Stuck Open
Outdoor Air Quality Sensor – Indicates if the outdoor air quality (CO ₂) sensor fails.	R: Normal/Alarm
Setpoint Slider – Indicates if the T56 sensor's setpoint slider potentiometer fails.	R: Normal/Alarm
Switch Configuration – Indicates if a duplicate configuration exists for two or more binary Input 3, 5, 8, & 9 Functions.	R: Normal/Alarm
Analog Input Configuration – Indicates if a duplicate configuration exists at the analog Input 1 & 2 Functions.	R: Normal/Alarm
Supply Fan Runtime – Indicates if the supply fan runtime exceeds the value of the Supply Fan Service Alarm Timer .	R: Normal/Alarm
Compressor 1 Runtime – Indicates if the compressor 1 runtime exceeds the value of the Compressor 1 Service Alarm Timer .	R: Normal/Alarm
Compressor 2 Runtime – Indicates if the compressor 1 runtime exceeds the value of the Compressor 2 Service Alarm Timer .	R: Normal/Alarm
Airside Linkage – Indicates if Linkage has failed in a zoned system using Linkage.	R: Normal/Alarm

Linkage

Navigation: i-Vu® / Field Assistant: **Properties > Control Program > Configuration > Service Configuration**

Point Name/Description	Range
<p>Linkage Collector – Allows access to the Collector's details.</p> <p>Click to see the following properties on the Summary tab of microblock popup:</p>	
<p>Application Type – This parameter indicates the type of Linkage application. (Display only)</p>	D: Airside Linkage
<p>Application Instance – Should always be 1 for i-Vu®/Field Assistant Systems.</p> <p>NOTE If using a CCN and BACnet System (i.e., CCN Air Terminal to BACnet Air Source), the Application Instance can be 1, 2, 3, or 4, depending on the number of air sources used in the system.</p>	D: 1 R: 1 2 3 4
<p>Maximum Providers – Indicates the maximum configurable size of the VVT zoning system. (Display only - fixed value)</p>	D: 64
<p>Number of Providers – Must be set to 0.</p>	D: 0
<p>Input Values – Indicates the maximum number of parameters in the collector array for each device. (Display only)</p>	D: 24
<p>Feedback Values – Indicates the maximum number (4 possible) of parameters in the collector array for any RTU Open. (Display only - fixed value)</p>	D: 8
<p>Feedback Update Time – Indicates the typical update rate of this application. (Display only - fixed value)</p>	D: 60 sec
<p>Input Expiration Time – Indicates the maximum time that the data received from the master zones, since the last refresh, is considered as valid. (Display only - fixed value)</p>	D: 300 sec
<p>Airside Linkage Status – If Active, the controller is part of a linked system. If Not Active, the controller is a stand-alone device.</p>	R: Active/Not Active

Point Name/Description	Range
<p>If Airside Linkage Status is Active, the following information is received from the Zoning System Master Zone, as applicable:</p> <ul style="list-style-type: none"> Occupancy Status Space Temperature Occupied Cooling Setpoint Occupied Heating Setpoint Unoccupied Cooling Setpoint Unoccupied Heating Setpoint Indoor Air CO2 Space Relative Humidity Linkage Max Damper Position Linkage Optimal Start <p>The following information is sent back to the Zoning System Master Zone:</p> <ul style="list-style-type: none"> Air Source Mode Air Source Supply Air Temp Air Source Outdoor Air Temp 	

I/O Points

The values shown on the **I/O Points Properties** page are the raw values at the I/O objects and may not match values shown on status displays that are affected by control program logic.

i-Vu® users logged in as **Power User** and above are able to edit various parameters associated with the input channels and the display names for all channels.

We strongly recommend that you leave these parameters at their defaults. The RTU Open is not a programmable controller. I/O can only be used for the purpose designed in the equipment control program. Modifying these parameters may result in unpredictable equipment control.

See *Wiring inputs and outputs* (page 12) for more information. This table lists each of the I/O Channels, their functions, associated hardware, and terminal numbers.

Navigation: i-Vu® / Field Assistant: **Properties > I/O Points**

Point Name/Description
<p>SPT Temp Sensor/Zone Temp</p> <ul style="list-style-type: none"> • SPT Temp Sensor - (For the SPT Standard, SPT Plus, and SPT Pro sensors only). Sensor configurations on the microblock's Properties > Details tab are listed below. For more information, see the <i>Carrier Sensors Installation Guide</i>. • Zone Temp - do not adjust these settings.
<p>Input 1 – Input Channel 1; 4 - 20 mA only. User-configurable for IAQ, OAQ, or Space Relative Humidity.</p>
<p>Input 2 – Input Channel 2; 4 - 20 mA only. User-configurable for IAQ, OAQ, or Space Relative Humidity.</p>
<p>Input 6 – Input Channel 6; 10K Thermistor only. Supply Air Temperature.</p>

Point Name/Description
Input 7 – Input Channel 7; 10K Thermistor only. Outside Air Temperature.
Input 10 – Input Channel 10; 10K Thermistor only. Space Temperature (T55, 56, 59).
Input 11 – Input Channel 11; 100K Potentiometer only. Setpoint adjust (T56, 59).
sliddepot voltage reading – Input Channel 11; used to detect an open circuit (faulty Setpoint adjustment mechanism).
ZS Zone CO2 - IAQ/CO2 signal received from CO2-enabled ZS Sensor(s).
ZS Zone Humidity - RH signal received from humidity-enabled ZS Sensor(s).
ZS Zone Temp - Temperature signal received from ZS Sensor(s).
Input 3 – Input Channel 3; Dry Contact only. User-configurable for No Function, Compressor Safety, Fan Status, Filter Status, Remote Occupancy, or Door Contact.
Input 4 – Input Channel 4; Dry Contact only. Safety Chain.
Input 5 – Input Channel 5; Dry Contact only. User-configurable for No Function, Fire Shutdown, Fan Status, Filter Status, Remote Occupancy, or Door Contact.
Input 8 – Input Channel 8; Dry Contact only. User-configurable for No Function, Enthalpy, Fan Status, Filter Status, Remote Occupancy, or Door Contact.
Input 9 – Input Channel 9; Dry Contact only. User-configurable for No Function, Humidistat, Fan Status, Filter Status, Remote Occupancy, Door Contact, or IGC Override.
Sensor Invalid – Reflects the status of the Space Temp (Rnet) input. On = Space Temp invalid Off = Space Temp valid
Econ - AO 1 – Analog Output Channel 1; 4-20 mA jumper-selectable to 2-10 Vdc. Signal used for Economizer control.
VFD - AO 2 – Analog Output Channel 2; 0-10 Vdc or 2-10 Vdc user-configurable. Provides VFD Output signal used for Variable Speed fan control.
G - Relay 1 – Binary Output 1; Fan (G) Output.
W2 - Relay 2 – Binary Output 2; Heat 2 (W2) Output.
W1 - Relay 3 – Binary Output 3; Heat 1 (W1) Output.
Y2 - Relay 4 – Binary Output 4; Cool 2 (Y2) Output.
Y1 - Relay 5 – Binary Output 5; Cool 1 (Y1) Output.
Dehum - Relay 6 – Binary Output 6; Humidi-MiZer™ Output.
Y3 - Relay 7 – Binary Output 7; Reversing Valve Output or High Speed Fan Output or Y3.
PE - Relay 8 – Binary Output 8; Power Exhaust Output.

Appendix B: Single Point Linkage and Device Address Binding

Single Point Linkage

The RTU Open receives data from other Open controllers when they are installed as part of an i-Vu® Control System. The data transfer may take the form of Single Point Linkage (SPL), which is automatic, or Device Address Binding, which you must configure.

Currently, the RTU Open implements Single Point Linkage for 2 variables:

- **System Cool Demand Level**
- **System Heat Demand Level**

Network Points for which SPL has been implemented are displayed in Field Assistant and the i-Vu® interface on the **Properties** page > **Network Points** tab.

The following example involves outside air temperature. **System Heat & Cool Demand Level** behaves similarly, except that their usage involves a specific application loaded on a Universal Controller Open. See *UC Open Installation Guide* for additional information. In either case, note that the BACnet type and instance numbers specified in the **Address** field of these variables have been predefined.

Network variables for which SPL is used are easily identified on the **Properties** page > **Network Points** tab. The asterisk in the BACnet address invokes the SPL function. These addresses cause the controller to issue a BACnet “who has” command for this variable. The controller binds to the closest of the first 5 devices from which it receives a valid response.

Name	Type	Value	Locked	Default Value	Com Enabled	COV Enable	Refresh Time (mm:ss)	Address	Error
System Cool Demand Level	(ANI)	3.00	<input type="checkbox"/>	0	<input checked="" type="checkbox"/>		1:00	bacnet://AV:80004	0 No Error, bound to DEV:1610967, AV:80004
System Heat Demand Level (Primary) (Secondary)	(ANI)2	0.00	<input type="checkbox"/>	0	<input checked="" type="checkbox"/>		1:00	bacnet://AV:80005 bacnet://AV:80005 bacnet://AV:80005	7 Binding in progress 7 Binding in progress

Address containing * (asterisk) denotes Single Point Linkage

Predefined Type and Instance Number

Indicates successful binding

Device Address Binding

Device Address Binding (DAB) allows the controller to receive data from other Open controllers when they are connected by a network. The controller receives data from other Open or BACnet controllers when they are installed as part of an i-Vu® Control System. The data transfer takes the form of DAB, which you must configure.

Currently, the controller implements DAB for the following variables:

- **System Outdoor Air Temperature**
- **System Occupancy**
- **System Leaving Load Water Temp**
- **System Control Setpoint**
- **System Cool Demand Level**
- **System Space RH**

You can implement DAB on network points with an undefined BACnet address, displayed in Field Assistant and the i-Vu® interface on the **Properties** page > **Network Points** tab. See example below.

Name	Type	Value	Locked	Default Value	Com Enabled	COV Enable	Refresh Time (mm:ss)	Address	Error
System Outdoor Air Temperature	(ANI2)	-999.00	<input type="checkbox"/>	-999	<input checked="" type="checkbox"/>		10:00	bacnet://	0 No Error
(Primary)								bacnet://	0 No Error
(Secondary)								bacnet://	0 No Error

Undefined BACnet address
Currently "unbound"

Name	Type	Value	Locked	Default Value	Com Enabled	COV Enable	Refresh Time (mm:ss)	Address	Error
System Outdoor Air Temperature	(ANI2)	88.80	<input type="checkbox"/>	-999	<input checked="" type="checkbox"/>		10:00	Device Address Variable Number bacnet://1610151/AV:80001	0 No Error, bound to DEV:1610151, AV:80001
(Primary)								bacnet://1610151/AV:80001	0 No Error, bound to DEV:1610151, AV:80001
(Secondary)								bacnet://1610151/AV:80001	0 No Error, bound to DEV:1610151, AV:80001







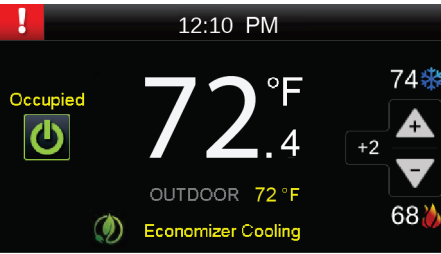
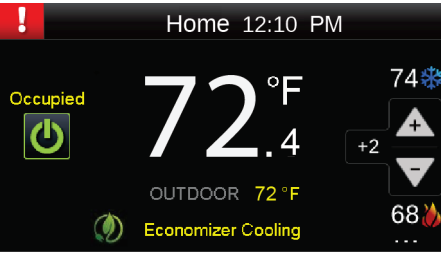

Indicates successful binding

Appendix C: RTU Open Points/Properties on the Equipment Touch

NOTE Engineering units shown in this document in the defaults and ranges are strictly for reference. You must enter an integer only.

Navigation screens

Screen Names	Display	Details
Standby		<p>Screen displays after the Inactivity Timer expires (default is 5 minutes).</p> <p>Displays:</p> <ul style="list-style-type: none"> • Space temperature • Current setpoints • Mode • Occupancy • OAT, if available <p>Not an interactive screen. Touch anywhere to advance to Home screen.</p>
Home		<p>Displays:</p> <ul style="list-style-type: none"> • Space temperature • Current setpoints • Mode • Occupancy • OAT, if available <p>Allows:</p> <ul style="list-style-type: none"> • Pushbutton Override • Space Setpoint Offset Adjustment <p>Click ... on the right to navigate to Snapshot screen.</p>

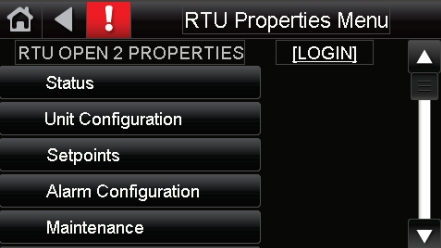
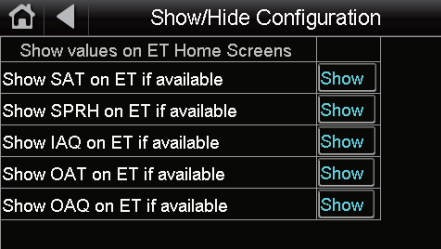
Screen Names	Display	Details												
Snapshot		<p>Displays:</p> <ul style="list-style-type: none"> • SAT, if allowed • RH, if available and allowed • IAQ, if available and allowed • OAQ, if available and allowed • OAT, if available and allowed • Fan speed • RTU Open alarms, if present  • Filter status  <p>Navigates to:</p> <ul style="list-style-type: none"> • Alarm status  • Schedules  • Trends  • Back to the Home screen - click  on the left • Forward to RTU Properties Menu screen - click  on the right 												
RTU Open Properties		<p>Navigates to Property pages</p> <p>Login with one of the following passwords:</p> <ul style="list-style-type: none"> ○ User level - type <code>user</code> ○ Admin level - type <code>admin</code> ○ Factory level - type <code>Touch</code> <p>NOTE Only the buttons that are authorized for a specific password level are visible.</p>												
Show/Hide Configuration	 <table border="1" data-bbox="386 1495 763 1684"> <thead> <tr> <th>Show values on ET Home Screens</th> <th></th> </tr> </thead> <tbody> <tr> <td>Show SAT on ET if available</td> <td>Show</td> </tr> <tr> <td>Show SPRH on ET if available</td> <td>Show</td> </tr> <tr> <td>Show IAQ on ET if available</td> <td>Show</td> </tr> <tr> <td>Show OAT on ET if available</td> <td>Show</td> </tr> <tr> <td>Show OAQ on ET if available</td> <td>Show</td> </tr> </tbody> </table>	Show values on ET Home Screens		Show SAT on ET if available	Show	Show SPRH on ET if available	Show	Show IAQ on ET if available	Show	Show OAT on ET if available	Show	Show OAQ on ET if available	Show	<p>You can configure Show/Hide conditions for values on the following screens:</p> <ul style="list-style-type: none"> • Standby • Home • Snapshot <p>NOTE Only displayed when logged in with the Factory or Admin password. (See above.)</p>
Show values on ET Home Screens														
Show SAT on ET if available	Show													
Show SPRH on ET if available	Show													
Show IAQ on ET if available	Show													
Show OAT on ET if available	Show													
Show OAQ on ET if available	Show													

Startup Wizard

Navigation: Equipment Touch: **Startup Wizard**

Point Name/Description	Range
<p>Unit Type – The type of equipment that the RTU Open is controlling.</p> <p>Options: Heat/Cool – Standard rooftop air handling unit. LC Weather Expert™ – A special factory-supplied 3-stage cooling unit HP O/B Ctrl – Heat Pump application, uses reversing valve output to control heating and cooling. HP Y1/W1 Ctrl – Carrier Heat Pump application only.</p>	<p>D: Heat/Cool</p> <p>R: Heat/Cool LC WeatherExpert™ HP O/B Ctrl HP Y1/W1 Ctrl</p>
<p>Heat Type – The type of heating used by the unit.</p>	<p>D: Electric</p> <p>R: Electric/Gas</p>
<p>Heat Stages – The number heat stages.</p>	<p>D: 2</p> <p>R: 1 / 2 /0 (no heating)</p>
<p>Compressor Stages – The number of mechanical cooling stages.</p>	<p>D: One Stage</p> <p>R: One Stage Two Stages</p>
<p>Fan Control – The type of fan control used on this unit.</p> <p>Automatically set to Variable Speed if Unit Type is set to LC WeatherExpert™.</p>	<p>D: Single Speed</p> <p>R: Single Speed Two Speed Variable Speed</p>
<p>Economizer Exists – Set to Yes to enable economizer control for units equipped with an economizer damper.</p>	<p>D: No</p> <p>R: No/Yes</p>
<p>Economizer High OAT Lockout Temp– The outdoor air temperature above which economizer cooling is inhibited.</p>	<p>D: 75 °F (23.9 °C)</p> <p>R: 55 to 80 °F (12.7 to 26.6 °C)</p>
<p>Vent Dmpr Pos / DCV Min Pos – The minimum outdoor air damper position maintained during occupied periods.</p>	<p>D: 20% Open</p> <p>R: 0 to 100%</p>
<p>Economizer Purge Min Pos – The minimum outdoor air damper position maintained during an unoccupied purge cycle when the Pre-Occ Purge mode is active.</p>	<p>D: 40% Open</p> <p>R: 0 to 100% Open</p>
<p>Low Fan Econ Min Pos – The minimum outdoor air damper position maintained during occupied periods when the fan is running at low speed (if configured for 2-speed fan control) or the minimum VFD speed (if configured for variable speed fan control).</p>	<p>D: 33% Open</p> <p>R: 0 to 100% Open</p>
<p>RH Control – Enables dehumidification control if an RH sensor or humidistat is available and the unit has the Humidi-MiZer™ dehumidification option installed.</p>	<p>D: Disable</p> <p>R: Disable/Enable</p>
<p>DCV Control – Enables demand controlled ventilation (DCV) if valid CO₂ sensor value is available and the unit has an economizer installed.</p>	<p>D: Disable</p> <p>R: Disable/Enable</p>

Point Name/Description	Range
DCV Max Vent Damper Pos – The maximum outdoor air damper position allowed while DCV is active.	D: 50% Open R: 0 to 75% Open
Reversing Valve Output – The type of reversing valve this unit uses.	D: 0 R: 0/B
HP Rev Cycle Lockout Temp – The outdoor air temperature below which reverse cycle heating is locked out. Once reverse cycle heating has been locked out, the OAT must rise 2Δ °F (1.1Δ °C) above this value to again allow heat pump reverse cycle heating. Requires that the unit be configured as a Heat Pump.	D: -3 °F (-19.4 °C) R: -20 to 65 °F (-28.9 to 18.3 °C)
Occupancy Source - The method that the controller uses to determine occupancy. Options: Always Occupied = Controller operates continuously as occupied. BACnet Schedule = Controller follows a schedule set up in Field Assistant or the i-Vu® application. BAS On/Off = Occupancy is set over the network by another device or a third party BAS. Remote Occ Input = Occupancy is set by a remote contact.	D: Always Occupied R: Always Occupied BACnet Schedule BAS On/Off Remote Occ Input
Input 1 Function – The type of sensor (4-20 mA) connected to terminals J4 – 4, 5, and 6.	D: No Sensor R: No Sensor IAQ Sensor OAQ Sensor Space RH Sensor
Input 2 Function – The type of sensor (4-20 mA) connected to terminals J4 – 1, 2, and 3.	D: No Sensor R: No Sensor IAQ Sensor OAQ Sensor Space RH Sensor
Input 3 Function – The usage of Input 3. You must also set Input 3 Switch Configuration . Options: No Function – The input is not used. Compressor Safety – Safety device status. Fan Status – Proves supply fan operation. Filter Status – Indicates a dirty filter. Remote Occupancy – Sets occupancy using a hardware contact. Door Contact – Disables mechanical cooling and electric or gas heating, when active.	D: Compressor Safety R: No Function Compressor Safety Fan Status Filter Status Remote Occupancy Door Contact
Input 5 Function – The usage of Input 5. You must also set Input 5 Switch Configuration . Options: No Function – The input is not used. Fire Shutdown – Fire Safety device status. Inhibits operation when tripped. Fan Status – Proves supply fan operation. Filter Status – Indicates a dirty filter. Remote Occupancy – Sets occupancy using a hardware contact. Door Contact – Disables mechanical cooling and electric or gas heating, when active.	D: Fire Shutdown R: No Function Fire Shutdown Fan Status Filter Status Remote Occupancy Door Contact
Input 5 Switch Configuration – The normal (de-energized) state for the set of contacts terminated at Input 5 .	D: NC R: NO/NC (normally open/normally closed)

Point Name/Description	Range
<p>Input 8 Function – The usage of Input 8. You must also set Input 8 Switch Configuration.</p> <p>Options:</p> <p>No Function – The input is not used.</p> <p>Enthalpy Switch – Indicates enthalpy status (high or low).</p> <p>Fan Status – Proves supply fan operation.</p> <p>Filter Status – Indicates a dirty filter.</p> <p>Remote Occupancy – Sets occupancy using a hardware contact.</p> <p>Door Contact – Sets occupancy using a hardware contact.</p>	<p>D: Enthalpy Switch</p> <p>R: No Function Enthalpy Switch Fan Status Filter Status Remote Occupancy Door Contact</p>
<p>Input 9 Function – The usage of Input 9. You must also set Input 9 Switch Configuration.</p> <p>Options:</p> <p>No Function – The input is not used.</p> <p>Humidistat – Indicates high humidity condition.</p> <p>Fan Status – Proves supply fan operation.</p> <p>Filter Status – Indicates a dirty filter.</p> <p>Remote Occupancy – Sets occupancy using a hardware contact.</p> <p>Door Contact – Sets occupancy using a hardware contact.</p> <p>IGC Override – Monitors the flame output from the Integrated Gas Control board. The input detects if a flame is still present after heating has been disabled.</p>	<p>D: Humidistat</p> <p>R: No Function Humidistat Fan Status Filter Status Remote Occupancy Door Contact IGC Override</p>

Status - Equipment Touch

Navigation: Equipment Touch: **Status**

Point Name/Description	Range
Equipment Status – The controller's current status.	R: Disabled Test Run
System Mode – The controller's current operating mode.	R: Off Fan Only Economizer Cooling Cooling Heating Dehumidification Test Shutdown Unocc Free Cooling Fire Shutdown IAQ Override Pre-occ Purge
Supply Fan Status – The current fan status if an input is configured for Fan Status .	R: Off/Running
Fan / Speed – The current commanded fan speed if Fan Control is set to Two Speed .	R: Off/Low/High
Supply Fan VFD – The current commanded output to the VFD to control the fan's speed if Fan Control is set to Variable Speed .	R: Off/Low/High

Point Name/Description	Range
Space Temperature - Prime Variable – The space temperature value currently used for control.	R: -56 to 245 °F (-48.9 to 118.3 °C)
Supply Air Temperature – Displays the current supply air temperature.	R: -56 to 245 °F (-48.9 to 118.3 °C)
Outdoor Air Temperature – The outdoor air temperature used for control.	R: -56 to 245 °F (-48.9 to 118.3 °C)
Space Relative Humidity – The current space relative humidity if a valid value exists either as a connected ZS sensor with RH or a hardware sensor connected to this controller (Configuration > Unit Configuration > Input 1 (or 2) Function is set to IAQ Sensor) or a value received through the Network or Linkage.	R: 0 to 100%rh
Indoor Air Quality CO2 (ppm) – The current space CO2 concentration if a valid value exists either as a connected ZS sensor with CO2 or a hardware sensor connected to this controller (Configuration > Unit Configuration > Input 1 (or 2) Function is set to IAQ Sensor) or a value received through the Network or Linkage.	R: 0 to 5000ppm
Outdoor Air Quality CO2 (ppm) – The current outdoor air CO2 concentration if the Configuration > Unit Configuration > Input 1 (or 2) Function is set to OAQ Sensor .	R: 0 to 5000ppm
Economizer Output – The current economizer output with respect to the outdoor air damper (if equipped).	R: 0 to 100% Open
Shutdown – When Active , all alarms are reset. (Any currently active alarms will continue to display.) Provides a means to stop heating and cooling in an orderly manner.	D: Inactive R: Inactive/Active

Unit Configuration - Equipment Touch

Navigation: Equipment Touch: **Unit Configuration**

Point Name/Description	Range
Fan Mode – The supply fan's operating mode. Options: Auto - The fan cycles on/off in conjunction with heating or cooling. Continuous - The fan runs continuously during occupancy and intermittently during unoccupied periods with heating or cooling. Always On - The fan runs continuously regardless of occupancy or calls for heating and cooling.	D: Continuous R: Auto Continuous Always On
Power Fail Restart Delay – How long the controller delays normal operation after the power is restored. Typically used to prevent excessive demand when recovering from a power failure.	D: 5 sec R: 0 to 30 sec
Fan Off Delay – The number of seconds that the fan continues to run after heating or cooling has ended.	D: 90 seconds R: 10 to 300

Point Name/Description	Range
Minimum Cooling SAT – In cooling mode, the cooling outputs are controlled so that the supply air temperature does not drop below this value.	D: 50 °F (10 °C) R: 45 to 75 °F (7.2 to 23.9 °C)
Maximum Heating SAT – In heating mode, the heating outputs are controlled so the supply air temperature does not rise above this value.	D: 120 °F R: 85 to 150 °F
Supply Fan Service Alarm Timer – A Supply Fan Runtime alarm is generated when the supply fan run hours exceed this value. Set to 0 to disable.	D: 600 hr R: 0 to 9999 hr
Filter Service Alarm Timer – The amount of time the fan will run before generating a Filter Alarm . Set to 0 to disable the alarm and reset accumulated fan hours.	D: 600 hr R: 0 to 9999 hr
Pushbutton Override – Enables or disables the use of a pushbutton override from a local space temperature sensor.	D: Enable R: Disable/Enable
Setpoint Adjustment – Enables or disables the setpoint adjustment mechanism on the local space sensor. Not displayed unless ZS or SPT sensor is connected.	D: Enable R: Disable/Enable
Setpoint Adjustment Range - The maximum amount that a user can adjust the setpoint on the local ZS or SPT sensor. Not displayed unless ZS or SPT sensor is connected.	D: 5Δ °F (2.7Δ °C) R: 0 to 5Δ °F (0 to 2.7Δ °C)
Cooling Lockout Temperature – Cooling is inhibited below this outdoor air temperature.	D: 45 °F (7.2 °C) R: -65 to 80 °F (-53.9 to 26.6 °C)
Economizer High OAT Lockout Temp – The outdoor air temperature above which economizer cooling is inhibited.	D: 75 °F (23.9 °C) R: 55 to 80 °F (12.7 to 26.6 °C)
Heating Lockout Temperature – Heating is inhibited above this outdoor air temperature.	D: 65 °F (18.3 °C) R: 35 to 150 °F (1.6 to 65.5 °C)
Pre Occupancy Purge – Enables or disables the use of a purge cycle immediately prior to the start of a scheduled occupied period.	D: Disable R: Disable/Enable
Purge Time – The maximum amount of time used for a pre-occupancy purge.	D: 60 minutes R: 0 to 240 minutes
Unocc Free Cool – Enables or disables the use of the economizer to provide unoccupied free cooling (NTFC).	D: Disable R: Disable/Enable

Setpoints - Equipment Touch

Navigation: Equipment Touch: **Setpoints**

Point Name/Description	Default/Range
<p>Occupied Heating – Green The heating setpoint the controller maintains while in occupied mode.</p>	<p>D: 70 °F (21.1 °C) R: 40 to 90 °F (4.4 to 32.2 °C)</p>
<p>Occupied Cooling – Green The cooling setpoint the controller maintains while in occupied mode.</p>	<p>D: 76 °F (24.4 °C) R: 55 to 99 °F (12.7 to 37.2 °C)</p>
<p>Unoccupied Heating – Gray The heating setpoint the controller maintains while in unoccupied mode.</p>	<p>D: 55 °F (12.7 °C) R: 40 to 90 °F (4.4 to 32.2 °C)</p>
<p>Unoccupied Cooling – Gray The cooling setpoint the controller maintains while in unoccupied mode.</p>	<p>D: 90 °F (32.2 °C) R: 45 to 99 °F (7.2 to 37.2 °C)</p>
<p>Optimal Start Type – The method used to change from unoccupied to occupied setpoint. Options: None – Unit will not change to occupied setpoint until the scheduled time or the unit goes into an occupied mode. Setpoints do not ramp, but change immediately from unoccupied to occupied values. Temp Compensated – Unit changes to occupied setpoints at a variable time prior to the occupied time, which is calculated by the current difference between space temperature and the appropriate heating or cooling setpoint. At that time, the setpoints do not ramp, but change immediately from unoccupied to occupied values. Learning Adaptive Start – Unit gradually changes to occupied setpoints by adjusting the unoccupied setpoints over a specified period of time to achieve the occupied setpoint by the time scheduled occupancy begins.</p>	<p>D: Temperature Compensated None R: Temperature Compensated Learning Adaptive</p>
<p>Heat Start K factor (min/deg) – If Optimal Start Type is Temp Compensated, this is the time in minutes per degree that the equipment starts before the occupied period when the space temperature is below the occupied heating setpoint (including any setpoint offset).</p>	<p>D: 15.00 R: 0 to 99</p>
<p>Cool Start K factor (min/deg) – If Optimal Start Type is Temp Compensated, this is the time in minutes per degree that the equipment starts before the occupied period when the space temperature is above the occupied cooling setpoint (including any setpoint offset).</p>	<p>D: 15.00 R: 0 to 99</p>

Occ Relative Humidity Setpoint – The percentage of relative humidity in the space during occupancy that will energize BO - 6 (Humidi-MiZer™).	D: 60%rh R: 0 to Unoccupied RH Control Setpoint
Unocc Relative Humidity Setpoint – The percentage of relative humidity in the space during the unoccupied time period that starts the unit and energizes BO - 6 (Humidi-MiZer™).	D: 95% R: 30 to 100%
DCV Max Ctrl Setpoint – The design difference between indoor and outdoor CO2 levels.	D: 650ppm R: 0 to 9999 ppm

Alarm Configuration - Equipment Touch

Navigation: Equipment Touch: **Alarm Configuration**

Point Name/Description	Default/Range
Space Temperature Alarm	
Occupied Alarm Hysteresis – This value is added to the occupied high effective setpoint and subtracted from the occupied low effective setpoint to establish the occupied high and low limits that the space temperature must exceed before an occupied SPT alarm is generated. The alarm returns to normal when the space temperature drops below the high effective setpoint or rises above the low effective setpoint.	D: 5Δ °F (2.7Δ °C) R: 0 to 20Δ °F (0 to 11.1Δ °C)
Unoccupied Low SPT Alarm Limit –The value that the space temperature must drop below to generate a Space Temperature Alarm in the unoccupied mode. There is a fixed hysteresis of 1Δ °F (.5Δ °C) for return to normal.	D: 45 °F (7.2 °C) R: 35 to 90 °F (1.6 to 32.2 °C)
Unoccupied High SPT Alarm Limit – The value that the space temperature must exceed to generate a Space Temperature Alarm in the unoccupied mode. There is a fixed hysteresis of 1Δ °F (.5Δ °C) for return to normal.	D: 95 °F (35 °C) R: 45 to 100 °F (7.2 to 37.7 °C)
Supply Air Temperature Alarm	
Low SAT Alarm Limit – The value that the supply air temperature must drop below to generate a Supply Air Temp Alarm . There is a fixed hysteresis of 1Δ °F (.5Δ °C) for return to normal.	D: 38 °F (3.3 °C) R: 15 to 90 °F (-9.4 to 32.2 °C)
High SAT Alarm Limit – The value that the supply air temperature must exceed to generate a Supply Air Temp Alarm . There is a fixed hysteresis of 1Δ °F (.5Δ °C) for return to normal.	D: 160 °F (71.1 °C) R: 90 to 175 °F (32.2 to 79.4 °C)
Space Humidity Alarm	

Point Name/Description	Default/Range
Occupied High RH Alarm Limit – The value that the relative humidity sensor must exceed to generate a Space Humidity Alarm in the occupied mode if RH Control is set to Enable . There is a fixed hysteresis of 5%rh for return to normal.	D: 70%rh R: 0 to 100%rh
Unocc High RH Alarm Limit – The value that the relative humidity sensor must exceed to generate a Space Relative Humidity alarm in the unoccupied mode if RH Control is set to Enable . There is a fixed hysteresis of 5%rh for return to normal.	D: 100%rh R: 0 to 100%rh
Low RH Alarm Limit – The value that the relative humidity sensor must drop below to generate a Space Humidity Alarm in either the unoccupied or occupied modes if RH Control is set to Enable . There is a fixed hysteresis of 5%rh for return to normal.	D: 30%rh R: 0 to 100%rh
IAQ/Ventilation Alarm	
Occupied High CO2 Alarm Limit – The value that the CO ₂ sensor must exceed to generate an IAQ Alarm in the occupied mode. There is a fixed hysteresis of 100ppm for return to normal. Requires a valid Indoor Air Quality CO2 sensor value and IAQ Control is set to Enable .	D: 1200ppm R: 0 to 9999 ppm

Maintenance - Equipment Touch

Navigation: Equipment Touch: **Properties > Control Program > Maintenance**

Point Name/Description	Default/Range
Unit	
Occupancy Status – The controller's occupancy status as determined by a network schedule, a local schedule, or a timed override.	R: Unoccupied/Occupied
Pre-Occ Purge – Indicates if the pre-occupancy purge cycle is active.	R: Inactive/Active
Setpoint Adjustment – Indicates the amount of offset applied if you configured the space sensor as a type of T56. Set the display value range in Setpoint Adjustment Range .	R: °F/C
Effective Heat Setpoint – The current heating setpoint. May include offsets from configured occupied/unoccupied setpoints resulting from Optimal Start to Demand Limit .	R: °F/C
Effective Cool Setpoint – The current cooling setpoint. May include offsets from configured occupied/unoccupied setpoints resulting from Optimal Start to Demand Limit .	R: °F/C
System Cooling Demand Level – The demand limit used by the control in cooling mode.	R: 0 to 3
System Heating Demand Level – The demand level used by the control in heating mode.	R: 0 to 3
Active Compressor Stages – The number of compressor stages currently operating.	R: 0 to 2
Active Heat Stages – The number of heating stages currently operating.	R: 0 to 2

Point Name/Description	Default/Range
Enthalpy (BACnet) – The enthalpy status the controller receives through BACnet communication.	R: High (0) / Low (1)
Reset Supply Fan Runtime Alarm – Set to Clear to reset Supply Fan Runtime to 0.	D: Run R: Run/Clear
Reset Filter Alarm – Set to On to reset Filter Runtime to 0.	D: Run R: Run/Clear
Occupancy	
<p>BAS On/Off – Determines the occupancy state of the controller and can be set over the network by another device or third party BAS.</p> <p>Options:</p> <p>Inactive – Occupancy is determined by a configured schedule. Occupied – The controller is always in the occupied mode. Unoccupied – The controller is always in the unoccupied mode.</p> <p>NOTE If BAS On/Off is set to either Unoccupied or Occupied, the Optimal Start routine is automatically disabled.</p>	D: Inactive R: Inactive Occupied Unoccupied
Pushbutton Override – Active indicates if a user pushed the sensor's override button to override the occupancy state.	R: Off/Active
Override Time Remaining – The amount of time remaining in an override period.	R: 0 to 240 minutes
Schedule – The controller's occupancy status based on the local schedule.	R: Unoccupied/Occupied
Airside Linkage	
Airside Linkage Status	R: OFF WARMUP HEAT COOL FREECOOL PRESSURIZE EVAC VENT NOT ACTIVE



Performance - Equipment Touch

Navigation: Equipment Touch: **Performance**

Point Name/Description	Range
Current Performance Data	
Equipment Runtime – RTU Open's hours of operation since the last reset of Performance Data .	R: __ hr
Economizer Utilization – Percentage of Equipment Runtime hours that are above the active Economizer time since the last reset of Performance Data .	R: 0 to 100%
DCV Utilization – Percentage of Equipment Runtime hours that are above the active DCV time since the last reset of Performance Data .	R: 0 to 100%
Unocc Free Cool Utilization – Percentage of Equipment Runtime hours that are above active Unoccupied Free Cooling since the last reset of Performance Data .	R: 0 to 100%
Part Load Cooling Utilization – Percentage of Equipment Runtime hours that are above Cooling time in which less than the maximum configured cooling stages were active since the last reset of Performance Data .	R: 0 to 100%
Full Load Cooling Utilization – Percentage of Equipment Runtime hours that are above Cooling time in which all of the configured cooling stages were active since the last reset of Performance Data .	R: 0 to 100%
Heating Utilization – Percentage of Equipment Runtime hours that are above active Heating time since the last reset of Performance Data .	R: 0 to 100%
Recorded High OAT – Maximum recorded OAT since the last reset of Performance Data .	R: __ °F/C
Recorded Low OAT – Minimum recorded OAT since the last reset of Performance Data .	R: __ °F/C

Alarms - Equipment Touch

Navigation: Equipment Touch: **Alarms**

Point Name/Description	Range
Click  for Help .	
Click  or  for Alarm History .	
Safety Chain – Indicates if the safety chain circuit trips.	R: Normal/Alarm

Point Name/Description	Range
Fire / Smoke Shutdown – Indicates if the fire shutdown circuit trips.	R: Normal/Alarm
Gas Valve – Indicates that the integrated gas valve is stuck open and a flame is still present while heat has been commanded off.	R: Normal/Alarm
Compressor Status – Indicates if the compressor safety circuit trips.	R: Normal/Alarm
Space Temperature – Indicates if the space temperature sensor exceeds the high or low alarm limit.	R: Normal/Alarm
Alarming Temperature – Indicates the space temperature value that caused the space temperature alarm. Visible only in an alarm condition.	R: The sensor's range
Alarm Limit Exceeded – The alarm limit that the alarming space temperature sensor exceeded. Visible only in an alarm condition.	R: The configured limit
SPT Sensor – Indicates if the SPT communicating zone temperature sensor is no longer communicating.	R: Normal/Alarm
Space Temp Sensor – Indicates that a valid space temperature sensor or sensor value is no longer available to the controller.	R: Normal/Alarm
Supply Air Temperature – Indicates if the supply air temperature exceeds the configured alarm limits.	R: Normal/Alarm
Supply Air Temp Sensor – Indicates if the supply air temperature sensor fails.	R: Normal/Alarm
Supply Fan Failure – The supply fan is not operating when commanded on.	R: Normal/Alarm
Supply Fan in Hand – The supply fan is operating when commanded off.	R: Normal/Alarm
Indoor Air Quality – Indicates if the occupied CO ₂ level exceeds the configured high alarm limit.	R: Normal/Alarm
Indoor Air Quality Sensor – Indicates that a valid indoor air quality sensor or sensor value is no longer available to the controller.	R: Normal/Alarm
Space Relative Humidity – Indicates that a valid space relative humidity sensor exceeds the configured alarm limits.	R: Normal/Alarm
Space Relative Humidity Sensor – Indicates that a valid space relative humidity sensor or sensor value is no longer available to the controller.	R: Normal/Alarm
Filter – Indicates a dirty filter condition when the filter runtime exceeds the value of the Filter Service Alarm Timer or in response to a filter status switch binary input.	R: Clean/Dirty
Local OAT Sensor – Indicates the local outdoor air temperature sensor connected to this equipment fails.	R: Normal/Alarm
Outdoor Air Temp Sensor – Indicates if the controller is no longer receiving a valid outdoor air temperature value either through the network or from a local sensor.	R: Normal/Alarm
Economizer Operation – Indicates the state of the economizer's operation and if an economizer Operation Fault has been detected.	R: Normal/Alarm
Economizer – If Economizer Operation has been set to Alarm , the Economizer Fault Detection Diagnostic Result displays.	R: Normal Failed to Fully Open Failed to Open Failed to Close Stuck Open
Outdoor Air Quality Sensor – Indicates if the outdoor air quality (CO ₂) sensor fails.	R: Normal/Alarm
Setpoint Slider – Indicates if the T56 sensor's setpoint slider potentiometer fails.	R: Normal/Alarm

Point Name/Description	Range
Switch Configuration – Indicates if a duplicate configuration exists for two or more binary Input 3, 5, 8, & 9 Functions.	R: Normal/Alarm
Analog Input Configuration – Indicates if a duplicate configuration exists at the analog Input 1 & 2 Functions.	R: Normal/Alarm
Supply Fan Runtime – Indicates if the supply fan runtime exceeds the value of the Supply Fan Service Alarm Timer .	R: Normal/Alarm
Compressor 1 Runtime – Indicates if the compressor 1 runtime exceeds the value of the Compressor 1 Service Alarm Timer .	R: Normal/Alarm
Compressor 2 Runtime – Indicates if the compressor 1 runtime exceeds the value of the Compressor 2 Service Alarm Timer .	R: Normal/Alarm
Airside Linkage – Indicates if Linkage has failed in a zoned system using Linkage.	R: Normal/Alarm

Document revision history

Important changes to this document are listed below. Minor changes such as typographical or formatting errors are not listed.

Date	Topic	Change description	Code*
4/24/17	Analog Outputs	Added the load impedance impedance when AO channels are used in a voltage output type application.	
4/18/17	Sequence of Operation - Cooling	Correction - OAT added to cooling algorithm re:economizer	C-TS-OC-BR
2/23/17	Specifications Wireless sensor overview To install the Wireless Adapter for wireless sensors Wiring devices to the RTU Open's Rnet port Input wiring specifications	Changed WS to wireless.	C-D
1/23/17	Startup Wizard	Correction - Property is always displayed in the Startup Wizard	C-AE-BR-E
	Sequence of operation - Linkage air source mode determination	Clarified reason and method for generating a particular mode. Evacuation/Shutdown changed to Evacuation.	C-AE-WB-E
	ZS sensor overview SPT sensor overview	Simplified. Detailed descriptions are available in specified manuals. Corrected total number of ZS sensors.	C-AE/TS-RD/WB-0
	Wireless sensor overview To install the Wireless Adapter for wireless sensors	New Topics	C-D
	Wiring devices to the RTU Open's Rnet port	Added Wireless Adapter for wireless sensors	C-D
	Input wiring specifications	Added Wireless Adapter for wireless sensors	C-D
	To wire the controller to the network	Added BACnet ARC156 connection information	C-D
	Wiring for communications	Changed from Wiring the RTU Open to the MS/TP network	C-D
	Specifications	Added BACnet ARC156 connection and Wireless Adapter for Carrier wireless sensors. Corrected SPT information.	C-D
11/23/16	Sequence of Operation - Linkage	Added Linkage system safety override for Heating Mode.	C-TS-WB-E-JN
2/24/16	Sequence of Operation - Indoor Air CO2	This section erroneously left out - reinserted.	C-TS-CB-E-WB
	Start-up	Added USB Link wiring caution.	C-TS-RD-E-JH
12/3/15	What is the RTU Open?	Note that metric version is available.	C-AE-WB
	Sequence of Operation	Indoor Air CO2 section deleted because same as Space Air Quality.	C-TS-RR-E
	Service Test	Correction - Service Test cannot be turned on or off from an Equipment Touch.	C-TS-RR-E
	Wiring and mounting the Equipment touch	Corrected the external 10 kOhm, Type II thermistor number from 33ZCT57SPT to 33ZCT55SPT	C-TS-PH

* For internal use only



CARRIER CORPORATION ©2017

A member of the United Technologies Corporation family · Stock symbol UTX · Catalog No. 11-808-499-01 · 4/24/2017