

Product Data



NOTE: Images are for illustration purposes only. Actual models may differ slightly.

TABLE OF CONTENTS

	PAGE
MODEL NUMBER NOMENCLATURE	3
STANDARD FEATURES AND ACCESSORIES	4
DIMENSIONS – OUTDOOR	5
CLEARANCES – OUTDOOR	8
SPECIFICATIONS – OUTDOOR COOLING ONLY	9
COMPATIBILITY	9
PERFORMANCE	9
SPECIFICATIONS – OUTDOOR HEAT PUMP	10
COMPATIBILITY	10
PERFORMANCE	10
COOLING PERFORMANCE DATA – (COOLING ONLY) ..	11
COOLING PERFORMANCE DATA – (HEAT PUMP)	12
HEATING PERFORMANCE DATA – (HEAT PUMP)	13
APPLICATION DATA	14
WIRING	15
AIR FLOW DATA	16
SOUND DATA	16
SOUND PRESSURE IN OCTAVE BANDS	16
ELECTRICAL DATA	17
FAN AND MOTOR SPECIFICATIONS	18
WIRING DIAGRAMS	19
GUIDE SPECIFICATIONS	25

INDUSTRY LEADING FEATURES / BENEFITS

A PERFECT BALANCE BETWEEN BUDGET LIMITS, ENERGY SAVINGS AND COMFORT.

The 38MHRB series ductless systems are a matched combination of an outdoor condensing unit and an indoor fan coil unit connected only by refrigerant tubing and wires.

The ductless system permits creative solutions to design problems such as:

- Add-ons to current space (an office or family room addition)
- Special space requirements
- When changes in the load cannot be handled by the existing system
- When adding air conditioning to spaces that are heated by hydronic or electric heat and have no ductwork
- Historical renovations or any application where preserving the look of the original structure is essential.

The ideal compliment to your ducted system when it is impractical or prohibitively expensive to use ductwork.

The compact indoor fan coil units take up very little space in the room and do not obstruct windows. The fan coils are attractively styled to blend with most room decors. Advanced system components incorporate innovative technology to provide reliable cooling performance at low sound levels.

Inverter Technology

The inverter driven compressor is designed to run at various input power frequencies (Hz) which controls the compressor's motor speed.

Even Temperature – The control package, including the inverter, monitors the outdoor and indoor temperatures as they relate to the selected indoor set point and adjusts the compressor speed to match the load and keep the system operating continuously rather than cycling and creating temperature swings. This translates to higher comfort levels for the occupants.

Rapid Pull Down/Warm-Up – Comfort is increased by the inverter system's ability to ramp up the compressor speed enabling the system to reach the user selected room temperature set point quicker.

Humidity Control – Running the system for longer periods and continuously varying the compressor speed enhances the humidity control.

Individual Room Comfort

Maximum comfort is provided because each space can be controlled individually based on the usage pattern.

Low Sound Levels

When noise is a concern, ductless systems are the answer. The indoor units are whisper quiet. There are no compressors indoors, either in the conditioned space or directly over it, and there is none of the noise usually generated by air being forced through the ductwork.

When sound ordinances and proximity to neighbors demand quiet operation, this outdoor unit is the right choice. With the inverter technology, these units run at lower speeds most of the time resulting in reduced sound levels.

Inverter Technology – Enhanced Economical Operation

Ductless systems are inherently economical to operate. Individual rooms are heated or cooled only when required, and since the air is delivered directly to the space, there is no need to use additional energy to move the air in the ductwork. This economical operation is enhanced further when the inverter system output matches the load resulting in a more efficient system.

Easy-To-Use Controls

The systems have microprocessor-based controls to provide the ultimate in comfort and efficiency. The user friendly wired and wireless remote controls provide the interface between the user and the unit.

Secure Operation

If security is an issue, outdoor and indoor units are connected only by refrigerant piping and wiring to prevent intruders from crawling through ductwork or wall openings. In addition, since the outdoor unit can be installed close to an outside wall, coils are protected from vandals and severe weather.

Fast Installation

This compact ductless system is simple to install. Only wires and piping need to run between the indoor and outdoor units. These units are fast and easy to install ensuring minimal disruption to customers in homes or the workplace. This makes these systems the equipment of choice for retrofit applications.

Simple Servicing and Maintenance

Removing the top panel of the outdoor unit provides immediate access to the control compartment, providing the service technician access to the diagnostic LEDs to facilitate the troubleshooting process. In addition, the draw-thru design of the outdoor unit means that dirt accumulates on the outside surface of the coil. Coils can be cleaned quickly from the inside using a pressure hose and detergent.

On the indoor units, service and maintenance expense is reduced due to the permanent easy to clean filters. Also, error codes are displayed on the front panel to alert the user to certain system malfunctions

Built-in Reliability

Ductless system indoor and outdoor units are designed to provide years of trouble-free operation.

Both the indoor and outdoor units are well protected. Whenever the microprocessor detects abnormal conditions, the unit stops and an error code appears.

Inverter systems provide additional reliability due to the soft start. This refers to the ability of the inverter to start the compressor motor using reduced voltage and reduced current. This feature is beneficial from an electrical standpoint (eliminates current spikes) as well as an overall reliability standpoint due to reduced stress on all associated system components.

Agency Listings

All systems are listed with AHRI (Air conditioning, Heating, and Refrigeration Institute) and are ETL certified per UL 1995 standard.

MODEL NUMBER NOMENCLATURE

OUTDOOR UNIT

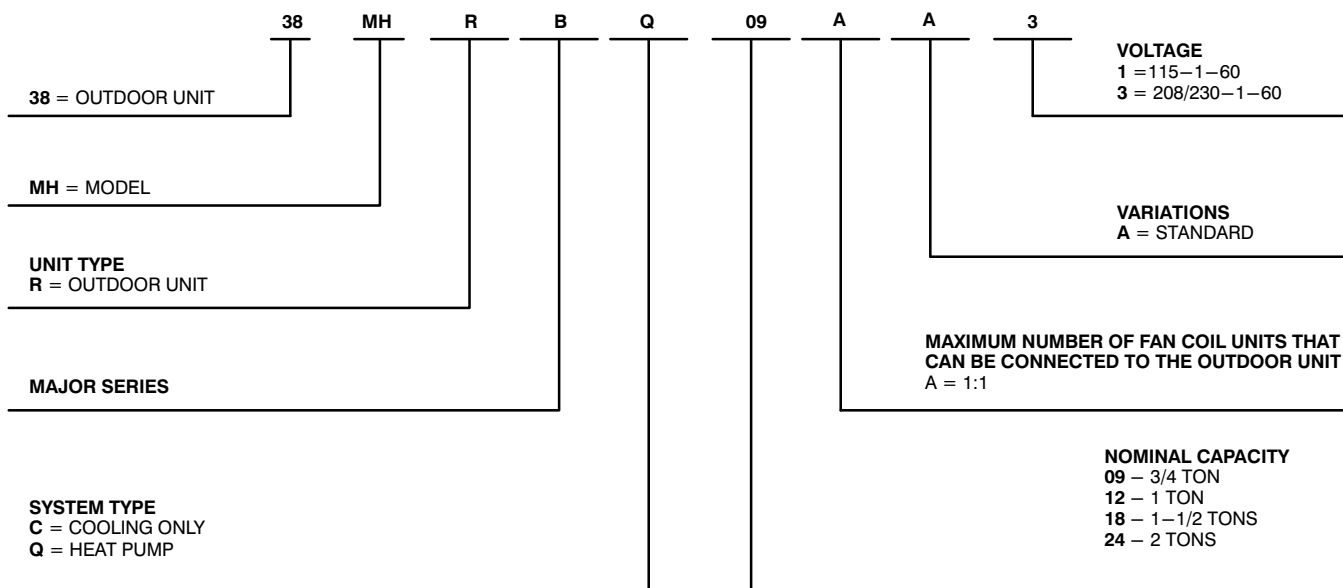

Use of the AHRI Certified TM Mark indicates a manufacturer's participation in the program. For verification of certification for individual products, go to www.ahridirectory.org.



STANDARD FEATURES AND ACCESSORIES

Ease Of Installation	
Low Voltage Controls	S
Comfort Features	
Microprocessor Controls	S
Auto Restart Function	S
Auto Changeover	S
Energy Saving Features	
Inverter Driven Compressor	S
46°F Heating Mode (Heating Setback)	S
Safety And Reliability	
3 Minute Time Delay For Compressor	S
High Compressor Discharge Temperature	S
Low Voltage Protection	S
Compressor Overload Protection	S
Compressor Over Current Protection	S
IPM Module Protection	S
Condenser High Temp Protection in Cooling Mode	S
Aluminum Golden Hydrophilic pre-coated fins	S
Ease Of Service And Maintenance	
Diagnostics	S
Liquid Line Pressure Taps	S
Application Flexibility	
Crankcase Heater	S
Base pan Heater on Heat Pump units Only	S

Legend
 S Standard
 A Accessory

OUTDOOR UNITS

Crankcase Heater

The crankcase heater is standard on all unit sizes. Heater clamps must be placed around the compressor oil stump.

Base pan Heater

The base pan heater is standard on all heat pump unit sizes.

ACCESSORIES

Outdoor Unit Model Number	Basepan Base Rubber Plugs RCD Part Number	Quantity per Unit	
38MHRBC12AA1	12600801A00077	12	
38MHRBC12AA3			
38MHRBC18AA3			
38MHRBC24AA3		25	
38MHRBQ12AA1		12	
38MHRBQ09AA3			
38MHRBQ12AA3			
38MHRBQ18AA3			13
38MHRBQ24AA3			25

NOTE: The basepan is constructed with multiple holes to provide proper draining during defrost. For applications where is required to seal these holes, and re-direct the condensate drain, rubber plugs are available through RCD.

DIMENSIONS – OUTDOOR

	System Size		Height (H) in. (mm)	Width (W) in. (mm)	Depth (D) in. (mm)	Weight—Net lbs. (kg)
	Cooling Only	12K	(115V)	21.85(555)	30.31(770)	11.81(300)
12K		(208/230V)	21.85(555)	30.31(770)	11.81(300)	53.8(24.4)
18K		(208/230V)	21.85(555)	30.31(770)	11.81(300)	65.9(29.9)
24K		(208/230V)	27.64(702)	33.27(845)	14.29(363)	88.6(40.2)
Heat Pump	System Size		Height (H) in. (mm)	Width (W) in. (mm)	Depth (D) in. (mm)	Weight—Net lbs. (kg)
	12K	(115V)	21.85(555)	30.31(770)	11.81(300)	69(31.3)
	9K	(208/230V)	21.85(555)	30.31(770)	11.81(300)	63(28.6)
	12K	(208/230V)	21.85(555)	30.31(770)	11.81(300)	65.5(29.7)
	18K	(208/230V)	21.81(554)	31.50(800)	13.11(333)	79.6(36.1)
	24K	(208/230V)	27.64(702)	33.27(845)	14.29(363)	114.2(51.8)

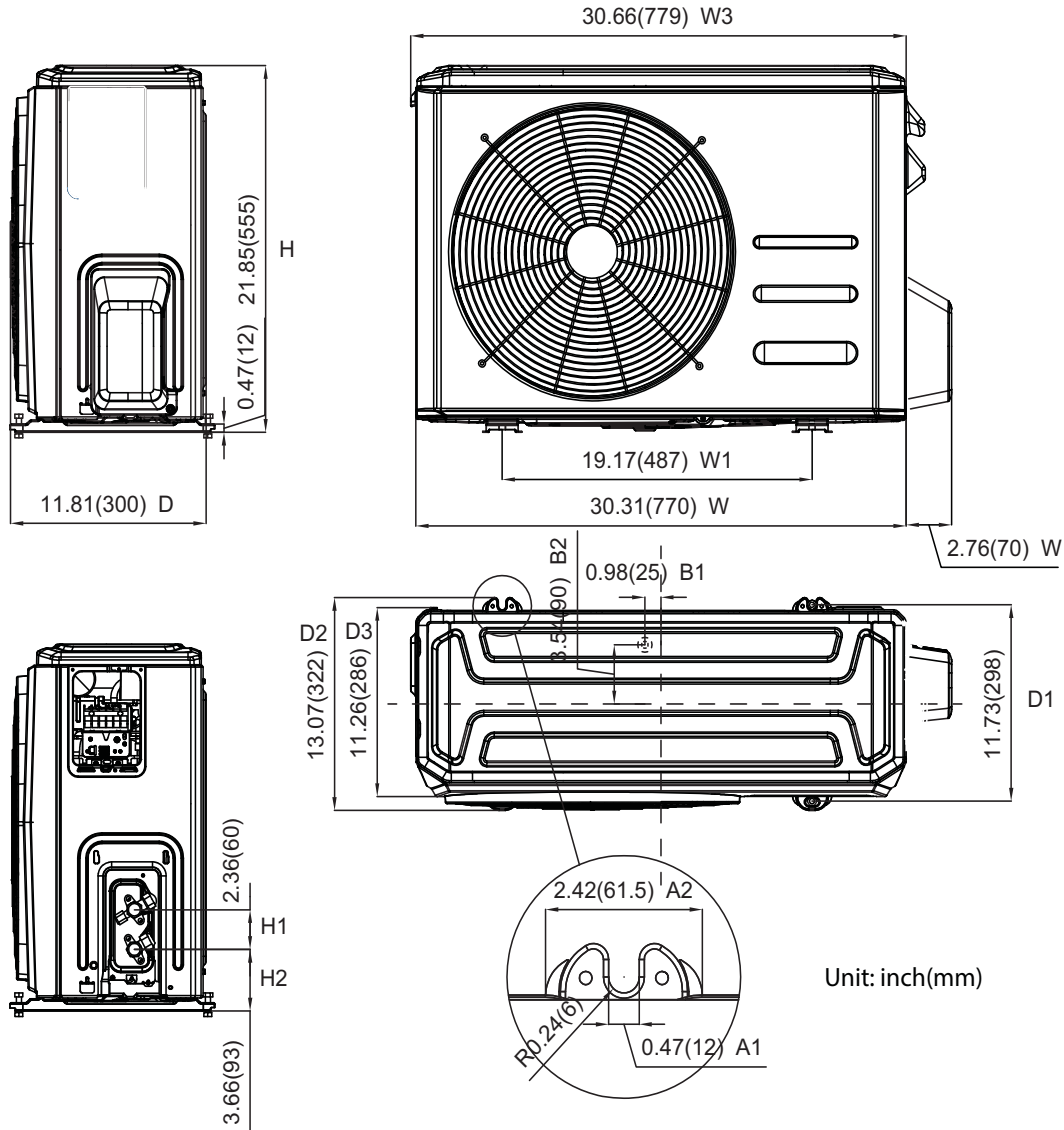
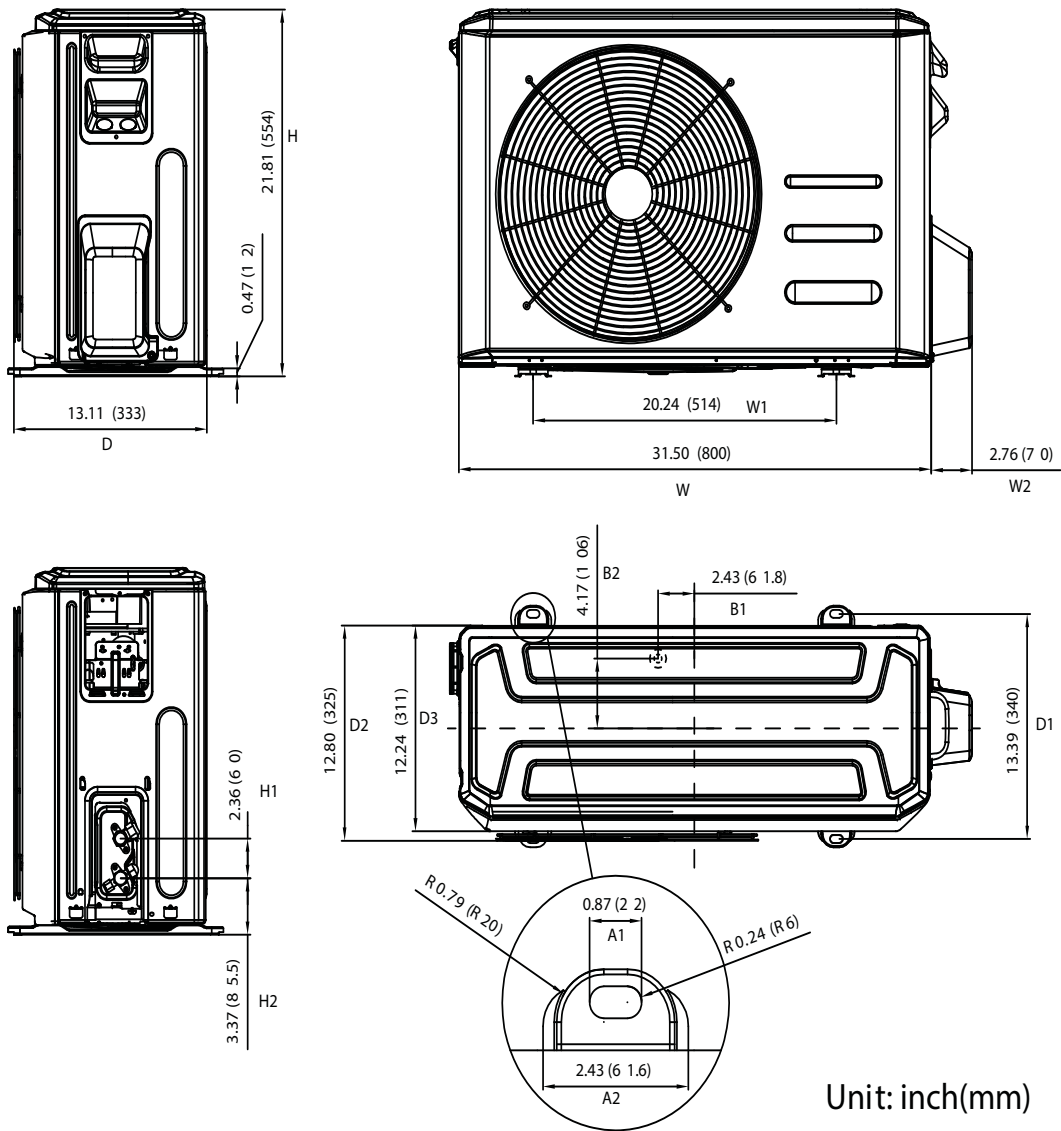

Fig. 1 – Sizes 9K and 12K Heat Pump and Size 18K Cooling Only

DIMENSIONS – OUTDOOR (CONT)



Unit: inch(mm)

Fig. 2 – Size 18K Heat Pump

DIMENSIONS – OUTDOOR (CONT)

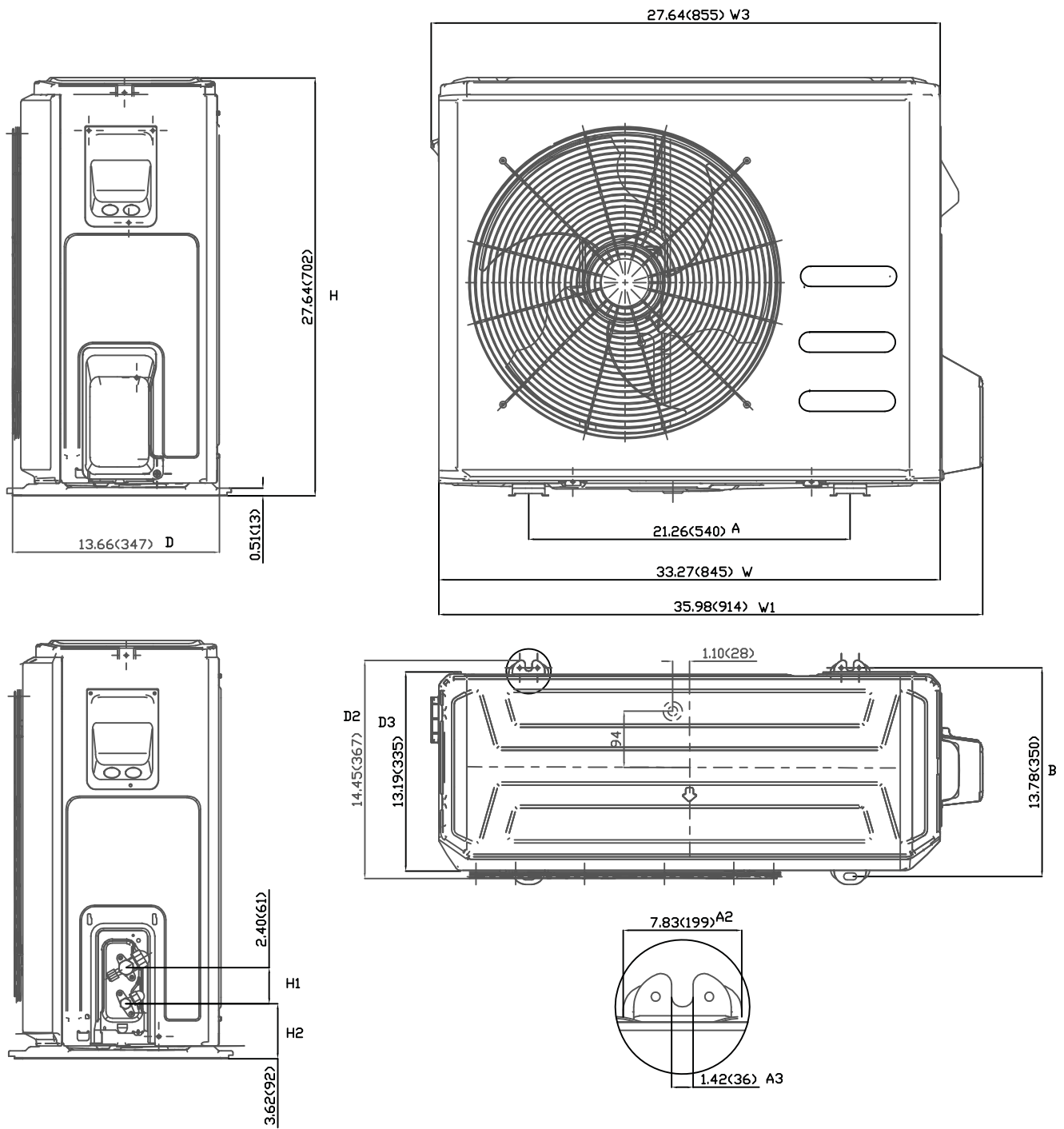

Unit: inch (mm)

Fig. 3 – Size 24K

CLEARANCES – OUTDOOR

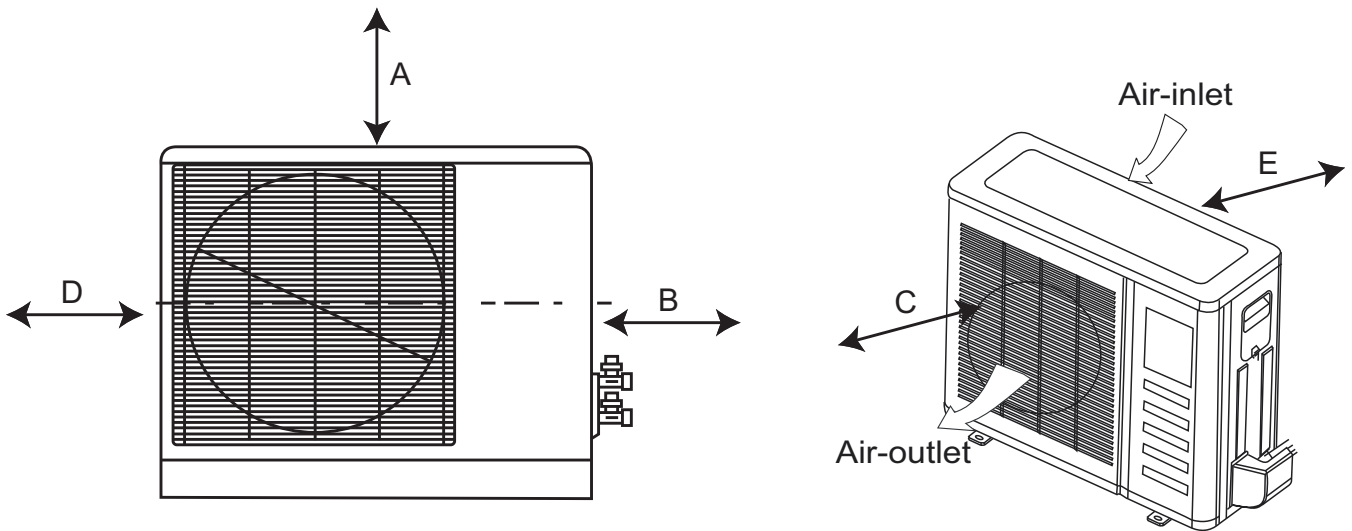

Fig. 4 – Outdoor Unit Clearance

UNIT	MINIMUM VALUE in. (mm)
A	24 (610)
B	24 (610)
C	24 (610)
D	4 (101)
E	4 (101)

NOTE: The outdoor unit must be mounted at least 2in. (50mm) above the maximum anticipated snow depth.

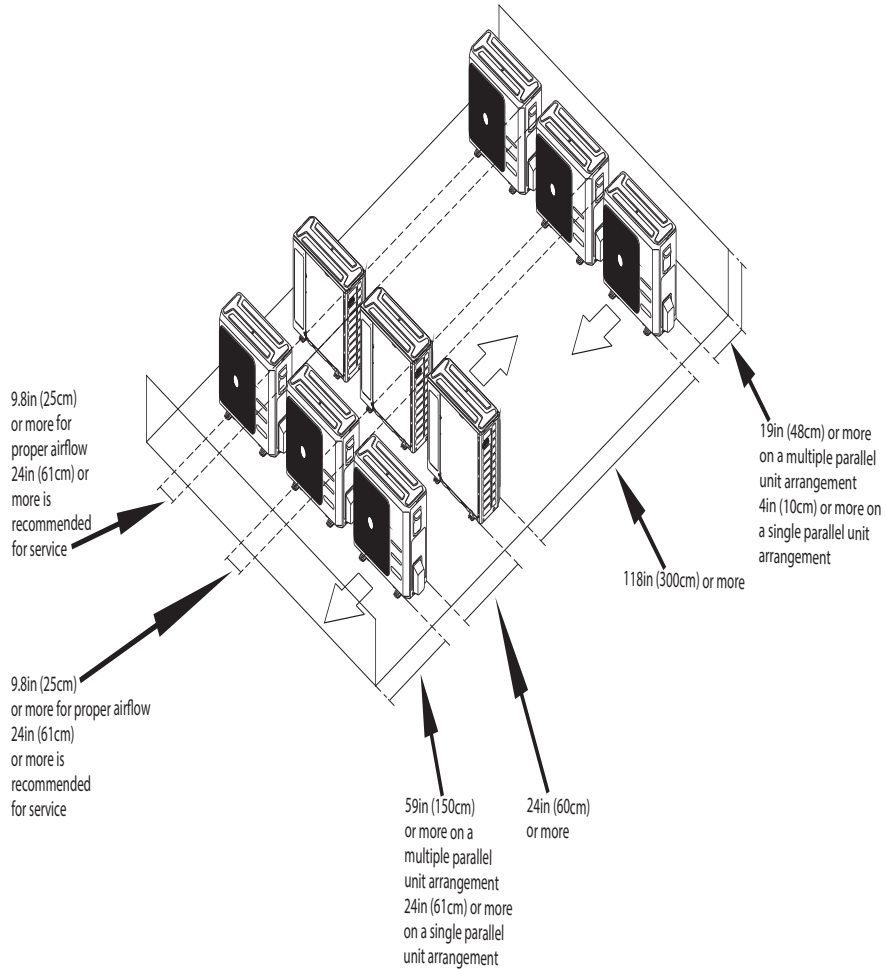

Fig. 5 – Clearances for multiple units

SPECIFICATIONS – OUTDOOR COOLING ONLY

System	Size		12	12	18	24
		Outdoor Model		38MHRBC12AA1	38MHRBC12AA3	38MHRBC18AA3
Electrical	Voltage, Phase, Cycle	V/Ph/Hz	115-1-60	208/230-1-60	208/230-1-60	208/230-1-60
	MCA	A.	13	11	15	18
	MOCP – Fuse Rating	A.	20	15	20	25
Operating Range	Cooling Outdoor DB Min – Max	° F (° C)	0~122 (-17~50)	0~122 (-17~50)	0~122 (-17~50)	0~122 (-17~50)
Piping	Total Piping Length	ft (m)	82 (25)	82 (25)	98 (30)	164 (50)
	Piping Lift*	ft (m)	33 (10)	33 (10)	66 (20)	66 (20)
	Pipe Connection Size – Liquid	in (mm)	1/4 (6.35)	1/4 (6.35)	1/4 (6.35)	3/8 (9.52)
	Pipe Connection Size – Suction	in (mm)	1/2 (12.7)	1/2 (12.7)	1/2 (12.7)	5/8 (16)
Refrigerant	Type		R410A	R410A	R410A	R410A
	Charge	lbs (kg)	1.30 (0.59)	1.17 (0.53)	1.98 (0.90)	2.56 (1.16)
	Metering Device		EEV	EEV	EEV	EEV
Outdoor Coil	Face Area	Sq. Ft.	4.15	4.15	4.15	4.78
	No. Rows		1	1	2	2
	Fins per inch		22	22	22	22
	Circuits		2	2	4	6
Compressor	Type		Rotary Inverter	Rotary Inverter	Rotary Inverter	Rotary Inverter
	Model		ASN98D22UFZ	ASK89D29UEZD	ASN140D21UFZ	ATN150D30UFZA
	Oil Type		VG74	VG74	VG74	VG74
	Oil Charge	Fl. Oz.	13.0	13.0	15.5	23.6
	Rated Current	RLA	9.5	6.8	9.0	12.0
Outdoor	Unit Width	in (mm)	30.31 (770)	30.31 (770)	30.31 (770)	33.27 (845)
	Unit Height	in (mm)	21.85 (555)	21.85 (555)	21.85 (555)	27.64 (702)
	Unit Depth	in (mm)	11.81 (300)	11.81 (300)	11.81 (300)	14.29 (363)
	Net Weight	lbs (kg)	57.8 (26.2)	53.8 (24.4)	65.9 (29.9)	88.6 (40.2)
	Airflow	CFM	1,170	1,230	1,195	1,825
	Sound Pressure	dB(A)	52.0	53.6	55.3	58.0

* Condensing unit above or below indoor unit

COMPATIBILITY

Indoor Unit		38MHRBC12AA1	38MHRBC12AA3	38MHRBC18AA3	38MHRBC24AA3
High Wall	40MHHC12---1	•			
	40MHHC12---3		•		
	40MHHC18---3			•	
	40MHHC24---3				•

PERFORMANCE

		40MHHC12---1	40MHHC12---3	40MHHC18---3	40MHHC24---3	
High Wall	Indoor Model					
	Energy Star		NO	NO	NO	
	Cooling System Tons		1.0	1.0	1.4	1.8
	Cooling Rated Capacity	Btu/h	12,000	11,500	17,000	22,000
	Cooling Cap. Range Min – Max	Btu/h	4,800~13,200	4,800~13,000	5,800~18,600	4,900~24,100
	SEER		17.3	19.0	19.0	18.5
	EER		10.7	11.2	10.3	11.1

SPECIFICATIONS – OUTDOOR HEAT PUMP

System	Size		12	9	12	18	24
			Outdoor Model	38MHRBQ12AA1	38MHRBQ09AA3	38MHRBQ12AA3	38MHRBQ18AA3
Electrical	Voltage, Phase, Cycle	V/Ph/Hz	115-1-60	208/230-1-60	208/230-1-60	208/230-1-60	208/230-1-60
	MCA	A.	13	8	10	15	18
	MOCP – Fuse Rating	A.	20	15	15	20	25
Operating Range	Cooling Outdoor DB Min – Max	° F (° C)	0~ 122 (-17~ 50)	0~ 122 (-17~ 50)	0~ 122 (-17~ 50)	0~ 122 (-17~ 50)	0~ 122 (-17~ 50)
	Heating Outdoor DB Min – Max	° F (° C)	0~ 86 (-17~ 30)	0~ 86 (-17~ 30)	0~ 86 (-17~ 30)	0~ 86 (-17~ 30)	0~ 86 (-17~ 30)
Piping	Total Piping Length	ft (m)	82 (25)	82 (25)	82 (25)	98 (30)	164 (50)
	Piping Lift*	ft (m)	33 (10)	33 (10)	33 (10)	66 (20)	66 (20)
	Pipe Connection Size – Liquid	in (mm)	1/4 (6.35)	1/4 (6.35)	1/4 (6.35)	1/4 (6.35)	3/8 (9.52)
	Pipe Connection Size – Suction	in (mm)	1/2 (12.7)	3/8 (9.52)	1/2 (12.7)	1/2 (12.7)	5/8 (16)
Refrigerant	Type		R410A	R410A	R410A	R410A	R410A
	Charge	lbs (kg)	2.12 (0.96)	1.76 (0.80)	2.12 (0.96)	2.82 (1.28)	3.97 (1.80)
	Metering Device		EEV	EEV	EEV	EEV	EEV
Outdoor Coil	Face Area	Sq. Ft.	4.1	4.1	4.1	4.7	5.3
	No. Rows		1.6	1	1.6	2	2
	Fins per inch		18	18	18	21	18
	Circuits		2	2	4	4	6
Compressor	Type		Rotary Inverter	Rotary Inverter	Rotary Inverter	Rotary Inverter	Rotary Inverter
	Model		ASN98D22UFZ	ASN98D22UFZ	ASN98D22UFZ	ASN140D21UFZ	ATF235D22UMT
	Oil Type		VG74	VG74	VG74	VG74	VG74
	Oil Charge	Fl. Oz.	13.0	13.0	13.0	15.5	23.6
	Rated Current	RLA	10.5	5.5	6.8	10.5	12.0
Outdoor	Unit Width	in (mm)	30.31 (770)	30.31 (770)	30.31 (770)	31.50 (800)	33.27 (845)
	Unit Height	in (mm)	21.85 (555)	21.85 (555)	21.85 (555)	21.81 (554)	27.64 (702)
	Unit Depth	in (mm)	11.81 (300)	11.81 (300)	11.81 (300)	13.11 (333)	14.29 (363)
	Net Weight	lbs (kg)	69 (31.3)	63 (28.6)	65.5 (29.7)	79.6 (36.1)	114.2 (51.8)
	Airflow	CFM	1,170	1,170	1,170	1,170	1,765
	Sound Pressure	dB(A)	54.5	57.2	57.4	57.0	60.2

* Condensing unit above or below indoor unit

COMPATIBILITY

Indoor Unit		38MHRBQ12AA1	38MHRBQ09AA3	38MHRBQ12AA3	38MHRBQ18AA3	38MHRBQ24AA3
High Wall	40MHHQ12---1	•				
	40MHHQ09---3		•			
	40MHHQ12---3			•		
	40MHHQ18---3				•	
	40MHHQ24---3					•

PERFORMANCE

	Indoor Model		40MHHQ12---1	40MHHQ09---3	40MHHQ12---3	40MHHQ18---3	40MHHQ24---3
			Energy Star	NO	NO	NO	NO
High Wall	Cooling System Tons		1.0	0.8	1.0	1.5	2.0
	Cooling Rated Capacity	Btu/h	12,000	9,000	12,000	18,000	24,000
	Cooling Cap. Range Min – Max	Btu/h	3,700~ 13,000	3,400~ 10,500	3,700~ 13,000	5,500~ 19,000	8,987~ 26,585
	SEER		19.8	18.5	19.8	19.0	17.3
	EER		10	11.2	11.2	11.2	9.7
	Heating Rated Capacity (47° F)	Btu/h	12,000	9,800	12,000	18,000	24,800
	Heating Rated Capacity (17° F)	Btu/h	8,000	7,500	9,230	11,600	18,000
	Heating Maximum Capacity (17° F)	Btu/h	8,200	7,850	9,500	11,800	18,300
	Heating Maximum Capacity (5° F)	Btu/h	9,000	6,070	8,880	10,150	16,760
	Heating Cap. Range Min – Max	Btu/h	3,500~ 13,500	2,800~ 11,500	3,500~ 13,500	6,200~ 19,000	8,371~ 25,350
	HSPF		10.6	10.0	9.6	10.6	9.6
	COP (47° F)	W/W	2.93	3.27	3.22	3.26	3.13
	COP (17° F)	W/W	2.58	2.58	2.64	2.64	2.49
	COP (5° F)	W/W	1.60	1.60	1.60	1.50	1.40

COOLING PERFORMANCE DATA – (COOLING ONLY)

Model	Cooling			Outdoor Conditions (DB)									
	Indoor Conditions			0F (-17C)	5F (-15C)	17F (-8C)	47F (8C)	77F (25C)	86F (30C)	95F (35C)	104F (40C)	113F (45C)	122F (50C)
	DB	WB											
12 (115V)	69.8F (21C)	59F (15C)	TC	6.54	6.67	7.33	8.42	8.57	11.44	9.94	8.98	7.80	4.84
			SC	5.60	5.77	6.08	6.20	6.32	7.72	6.98	6.53	6.00	4.67
			Input	0.21	0.21	0.25	0.30	0.56	1.16	1.03	1.04	1.03	0.80
	75.2F (24C)	62.6F (17C)	TC	6.99	7.13	7.84	9.01	9.24	12.18	10.66	9.67	8.41	5.43
			SC	6.00	6.19	6.51	6.64	6.83	8.16	7.46	7.03	6.48	5.24
			Input	0.20	0.21	0.24	0.30	0.56	1.19	1.06	1.06	1.05	0.81
	80.6F (27C)	66.2F (19C)	TC	7.46	7.61	8.36	9.61	10.94	12.99	12.32	10.26	9.06	5.97
			SC	6.36	6.56	6.90	7.04	7.30	8.60	7.88	7.43	6.94	4.72
			Input	0.20	0.21	0.24	0.30	0.56	1.22	1.08	1.08	1.07	0.81
	89.6F (32C)	73.4F (23C)	TC	12.04	12.28	13.50	15.52	14.21	14.69	12.90	11.76	10.47	7.13
			SC	8.20	8.45	8.89	9.07	8.68	8.85	8.19	7.79	7.34	6.20
			Input	0.56	0.57	0.67	0.81	0.94	1.28	1.14	1.13	1.10	0.83
12 (208-230V)	69.8F (21C)	59F (15C)	TC	7.16	7.31	8.03	9.23	8.72	8.75	9.83	8.31	7.07	4.56
			SC	6.21	6.40	6.74	6.87	6.70	6.71	7.24	6.48	5.89	4.56
			Input	0.31	0.32	0.37	0.45	0.59	0.73	1.10	1.02	1.01	0.79
	75.2F (24C)	62.6F (17C)	TC	7.64	7.80	8.57	9.85	9.58	11.84	10.69	9.07	7.76	5.02
			SC	6.63	6.83	7.19	7.34	7.26	8.32	7.80	7.07	6.43	5.02
			Input	0.31	0.32	0.38	0.46	0.60	1.12	1.12	1.03	1.02	0.79
	80.6F (27C)	66.2F (19C)	TC	8.16	8.33	9.15	10.52	11.25	12.71	11.98	9.76	8.45	5.59
			SC	7.03	7.25	7.63	7.78	7.55	8.79	8.37	7.56	6.94	5.59
			Input	0.32	0.33	0.39	0.47	0.56	1.15	1.15	1.04	1.03	0.80
	89.6F (32C)	73.4F (23C)	TC	11.49	11.72	12.88	14.80	14.83	14.65	13.37	11.35	9.92	6.56
			SC	8.37	8.63	9.08	9.27	9.28	9.26	8.80	8.04	7.41	6.18
			Input	0.73	0.75	0.88	1.07	1.07	1.22	1.22	1.09	1.07	0.81
18 (208-230V)	69.8F (21C)	59F (15C)	TC	7.85	11.21	12.32	14.16	15.32	17.55	15.92	13.84	11.90	7.57
			SC	6.86	9.80	10.32	10.53	10.16	12.14	11.37	10.38	9.52	7.34
			Input	0.26	0.40	0.46	0.57	0.80	1.63	1.59	1.48	1.47	1.15
	75.2F (24C)	62.6F (17C)	TC	7.29	10.41	11.44	13.15	14.28	18.35	16.97	14.93	13.03	8.51
			SC	6.75	9.64	10.15	10.36	10.91	12.73	12.10	11.18	10.36	8.27
			Input	0.21	0.33	0.38	0.47	0.80	1.65	1.62	1.52	1.49	1.16
	80.6F (27C)	66.2F (19C)	TC	7.38	10.55	11.59	13.32	15.17	18.99	18.15	15.98	14.10	9.36
			SC	6.85	9.79	10.31	10.52	11.60	13.18	12.69	11.92	11.17	9.16
			Input	0.21	0.33	0.38	0.46	0.81	1.69	1.65	1.55	1.52	1.17
	89.6F (32C)	73.4F (23C)	TC	7.41	10.59	11.64	13.38	19.66	19.99	18.99	17.42	15.97	11.05
			SC	6.52	9.32	9.81	10.01	12.92	13.07	12.70	12.14	11.65	10.14
			Input	0.21	0.33	0.38	0.46	1.41	1.71	1.69	1.60	1.57	1.19
24 (208-230V)	69.8F (21C)	59F (15C)	TC	15.85	16.44	16.52	17.16	18.06	21.39	19.68	17.54	14.38	11.13
			SC	11.92	12.27	13.05	13.15	14.32	15.45	14.02	12.94	11.40	9.89
			Input	0.88	0.89	1.14	1.66	1.70	1.83	2.31	2.23	2.04	1.87
	75.2F (24C)	62.6F (17C)	TC	16.98	17.22	18.69	19.21	21.81	23.68	22.14	18.88	15.89	12.50
			SC	12.73	12.88	13.77	13.98	15.52	16.10	15.61	13.87	12.55	10.93
			Input	0.90	0.90	1.32	1.67	1.92	2.12	2.36	2.28	2.08	1.90
	80.6F (27C)	66.2F (19C)	TC	17.72	18.15	19.03	21.60	23.26	25.91	24.80	22.59	20.29	17.30
			SC	13.31	13.54	13.94	15.13	15.92	17.35	17.99	15.75	14.75	13.42
			Input	0.89	0.91	1.51	2.01	2.13	2.61	2.72	2.43	2.34	2.12
	89.6F (32C)	73.4F (23C)	TC	19.71	20.04	20.16	23.50	24.81	26.29	25.24	25.13	23.12	20.12
			SC	13.74	13.86	15.95	16.18	18.17	17.95	16.66	16.11	15.35	14.13
			Input	0.93	0.99	1.74	2.21	2.54	2.74	2.81	2.51	2.45	2.21

LEGEND

DB - Dry Bulb
 WB - Wet Bulb
 TC - Total Net Capacity (1000BTU/hour)
 SC - Sensible Capacity (1000BTU/hour)
 Input - Total Power (kW)

COOLING PERFORMANCE DATA – (HEAT PUMP)

Model	Cooling			Outdoor Conditions (DB)									
	Indoor Conditions			0F (-17C)	5F (-15C)	17F (-8C)	47F (8C)	77F (25C)	86F (30C)	95F (35C)	104F (40C)	113F (45C)	122F (50C)
	DB	WB											
12 (115V)	69.8F (21C)	59F (15C)	TC	11.24	11.44	11.38	10.68	10.82	10.99	10.45	9.73	7.88	4.96
			SC	7.73	7.85	7.86	7.42	7.46	7.67	7.39	7.06	6.26	4.94
			Input	0.48	0.46	0.43	0.46	0.45	0.90	0.97	1.06	1.00	0.81
	75.2F (24C)	62.6F (17C)	TC	12.25	12.11	12.18	11.43	11.63	11.90	11.21	10.29	8.30	5.44
			SC	8.33	8.34	8.31	7.99	8.05	8.18	7.85	7.45	6.58	5.41
			Input	0.46	0.50	0.46	0.48	0.46	0.91	0.99	1.04	0.96	0.81
	80.6F (27C)	66.2F (19C)	TC	12.93	12.61	11.40	11.44	11.00	11.98	12.01	11.24	9.32	6.03
			SC	8.71	8.80	8.76	8.32	8.17	8.67	8.46	8.16	7.32	6.10
			Input	0.49	0.52	0.47	0.42	0.61	0.92	1.19	1.10	1.00	0.82
	89.6F (32C)	73.4F (23C)	TC	14.54	14.30	14.73	14.62	13.29	13.05	12.97	12.52	10.31	7.51
			SC	9.03	8.99	9.11	9.58	8.61	8.55	8.52	8.33	7.48	6.58
			Input	0.58	0.61	0.55	0.81	0.84	0.93	1.03	1.09	0.93	0.83
09 (208-230V)	69.8F (21C)	59F (15C)	TC	9.06	8.57	7.95	9.11	9.16	8.79	9.42	6.98	6.52	5.08
			SC	6.56	6.61	5.88	7.47	7.60	6.91	7.22	4.88	4.53	3.01
			Input	0.38	0.40	0.40	0.62	0.76	0.90	1.19	1.00	0.93	0.95
	75.2F (24C)	62.6F (17C)	TC	9.59	9.30	8.60	10.07	9.83	9.76	10.17	8.17	6.70	5.76
			SC	6.18	6.15	5.73	6.50	6.41	6.37	6.55	5.66	5.01	4.65
			Input	0.41	0.43	0.43	0.63	0.73	0.90	1.19	1.01	0.94	0.96
	80.6F (27C)	66.2F (19C)	TC	10.20	9.91	9.81	11.17	11.31	11.56	10.78	8.41	6.95	6.10
			SC	6.59	6.53	7.01	7.50	7.69	7.58	6.96	5.91	5.26	5.10
			Input	0.48	0.46	0.47	0.51	0.73	0.95	1.20	1.06	0.98	1.01
	89.6F (32C)	73.4F (23C)	TC	11.39	11.15	10.81	12.39	13.39	12.26	12.12	9.24	8.03	6.74
			SC	6.83	6.75	6.88	7.23	7.83	7.17	7.15	6.02	5.57	5.08
			Input	0.52	0.56	0.57	1.04	1.01	0.92	1.23	1.03	0.96	0.97
12 (208-230V)	69.8F (21C)	59F (15C)	TC	12.24	11.97	12.09	12.05	11.58	12.11	11.93	10.59	8.17	7.18
			SC	8.47	8.38	8.37	8.32	8.08	8.32	8.24	7.63	6.41	5.97
			Input	0.58	0.53	0.37	0.66	1.02	1.10	1.27	1.24	0.95	0.97
	75.2F (24C)	62.6F (17C)	TC	13.26	13.53	12.36	12.45	12.18	12.91	12.67	10.78	8.67	7.73
			SC	9.10	9.19	8.60	8.63	8.52	8.86	8.68	7.89	6.88	6.49
			Input	0.71	0.71	0.46	0.67	0.76	1.10	1.29	1.24	0.95	0.98
	80.6F (27C)	66.2F (19C)	TC	13.82	14.07	14.91	12.71	12.95	13.75	13.49	11.07	9.20	8.05
			SC	9.44	9.50	9.90	8.84	8.98	9.29	9.12	8.14	7.07	6.80
			Input	0.72	0.73	0.69	0.68	0.76	1.11	1.30	1.25	0.96	0.98
	89.6F (32C)	73.4F (23C)	TC	14.89	15.18	15.53	14.36	16.88	15.79	14.92	11.84	10.34	8.68
			SC	9.54	9.61	9.70	9.22	10.20	9.71	9.41	8.24	7.68	7.07
			Input	0.75	0.76	0.70	1.03	1.11	1.78	1.33	1.26	0.97	0.99
18 (208-230V)	69.8F (21C)	59F (15C)	TC	19.82	18.50	18.02	15.81	17.95	17.37	17.66	16.59	11.76	10.12
			SC	13.87	12.96	12.85	11.15	12.96	12.35	13.74	12.99	10.86	10.07
			Input	0.76	0.77	0.80	0.67	0.87	1.42	1.75	1.83	1.39	1.43
	75.2F (24C)	62.6F (17C)	TC	20.51	19.26	18.68	16.45	18.46	18.38	18.22	17.94	12.61	10.95
			SC	14.57	14.02	14.52	12.71	13.90	13.70	14.06	13.89	11.87	10.95
			Input	0.80	0.81	0.85	0.71	0.92	1.48	1.81	1.90	1.42	1.49
	80.6F (27C)	66.2F (19C)	TC	21.52	20.35	19.74	18.38	19.20	19.60	19.14	18.94	13.85	11.94
			SC	15.51	15.74	16.22	14.81	15.00	14.89	15.32	14.84	13.10	11.94
			Input	0.85	0.86	0.89	0.76	0.96	1.52	1.85	1.95	1.48	1.54
	89.6F (32C)	73.4F (23C)	TC	22.49	21.22	20.38	20.43	22.59	23.55	22.15	21.37	15.67	13.48
			SC	15.32	15.11	16.66	14.82	15.96	15.01	15.72	15.23	13.79	13.00
			Input	0.96	0.98	1.26	1.25	1.18	1.52	1.89	1.99	1.49	1.55
24 (208-230V)	69.8F (21C)	59F (15C)	TC	25.25	25.18	25.21	24.09	23.85	24.10	22.92	20.08	14.76	9.91
			SC	17.91	17.81	17.82	16.77	16.60	16.74	16.04	15.19	12.06	7.78
			Input	1.75	1.80	1.72	1.32	1.60	2.43	2.65	2.52	2.10	1.79
	75.2F (24C)	62.6F (17C)	TC	27.07	27.34	28.29	25.45	25.50	26.45	24.08	21.05	15.76	10.53
			SC	18.94	18.59	19.58	17.90	17.56	18.47	16.85	15.89	11.53	7.55
			Input	1.84	1.83	1.75	1.42	1.62	2.46	2.70	2.56	2.12	1.79
	80.6F (27C)	66.2F (19C)	TC	29.21	29.96	30.18	27.10	26.80	27.93	24.93	22.19	16.55	13.08
			SC	20.47	21.03	21.41	19.08	18.82	19.88	18.08	16.04	12.05	9.79
			Input	1.89	1.91	1.78	1.46	1.66	2.48	2.66	2.58	2.13	1.80
	89.6F (32C)	73.4F (23C)	TC	31.19	31.10	31.10	27.86	30.22	30.43	28.05	24.84	18.36	14.88
			SC	21.92	21.99	21.85	19.63	21.48	21.78	19.85	18.75	13.58	11.05
			Input	1.92	2.07	1.91	1.61	2.02	2.55	2.82	2.65	2.17	1.82

LEGEND

DB - Dry Bulb
 WB - Wet Bulb
 TC - Total Net Capacity (1000BTU/hour)
 SC - Sensible Capacity (1000BTU/hour)
 Input - Total Power (kW)

HEATING PERFORMANCE DATA – (HEAT PUMP)

Model	Heating			Outdoor Conditions (DB)							
	Indoor Conditions	0F (-17C)	5F (-15C)	17F (-8C)	19.4F (-7C)	24.8F (-4C)	32F (0C)	39.2F (4C)	44.6F (7C)	53.6F (12C)	
12 (115V)	59F (15C)	TC	5.65	6.37	7.89	8.78	9.55	10.55	11.46	12.45	12.89
		Input	0.82	0.88	0.90	0.92	0.99	0.99	1.15	1.21	1.01
		COP	2.03	2.11	2.57	2.79	2.84	3.11	2.92	3.01	3.73
	64.4F (18C)	TC	5.45	5.17	6.69	7.58	8.35	9.35	11.26	12.11	12.84
		Input	0.80	0.86	0.88	0.90	0.97	0.97	1.20	1.24	1.06
		COP	2.01	1.76	2.23	2.46	2.53	2.82	2.75	2.87	3.54
	69F (20.5C)	TC	5.25	4.37	5.89	6.78	7.55	8.55	11.16	12.03	12.75
		Input	0.78	0.84	0.86	0.88	0.95	0.95	1.21	1.26	1.07
		COP	1.98	1.52	2.01	2.25	2.34	2.63	2.70	2.80	3.48
	71.6F (22C)	TC	5.20	6.32	7.56	8.54	9.51	10.21	10.99	11.88	12.49
		Input	0.84	0.81	0.85	0.87	1.00	0.90	1.03	1.10	1.10
		COP	1.81	2.28	2.61	2.87	2.80	3.32	3.12	3.18	3.33
09 (208–230V)	59F (15C)	TC	7.28	7.70	8.53	9.43	10.05	10.45	11.33	11.92	12.68
		Input	1.17	1.14	1.15	1.17	1.03	0.94	0.95	1.02	1.12
		COP	1.82	1.99	2.17	2.35	2.85	3.26	3.49	3.44	3.32
	64.4F (18C)	TC	6.08	6.50	7.33	8.23	8.85	9.85	11.13	11.72	12.48
		Input	1.15	1.12	1.13	1.15	1.01	0.92	1.00	1.07	1.17
		COP	1.55	1.71	1.90	2.09	2.56	3.14	3.25	3.22	3.12
	69F (20.5C)	TC	5.28	5.70	6.53	7.43	8.05	9.05	10.03	11.63	12.38
		Input	1.13	1.10	1.11	1.13	0.99	0.90	1.01	1.08	1.18
		COP	1.37	1.52	1.72	1.92	2.38	2.95	2.90	3.16	3.07
	71.6F (22C)	TC	6.43	6.95	7.68	8.58	8.90	9.30	10.14	11.13	12.29
		Input	1.06	1.03	1.20	1.23	1.08	0.98	1.02	1.09	1.19
		COP	1.78	1.99	1.87	2.05	2.42	2.78	2.90	3.00	3.02
12 (208–230V)	59F (15C)	TC	7.91	8.89	9.84	10.87	11.11	11.35	11.86	12.41	13.00
		Input	0.83	1.27	0.81	1.37	0.90	1.01	1.17	1.51	1.04
		COP	2.79	2.06	3.54	2.32	3.61	3.30	2.98	2.41	3.66
	64.4F (18C)	TC	6.33	7.65	8.06	9.56	9.83	10.53	11.38	12.03	12.74
		Input	0.85	0.82	0.84	0.86	0.92	0.83	1.19	1.53	1.51
		COP	2.18	2.74	2.83	3.26	3.12	3.72	2.81	2.31	2.47
	69F (20.5C)	TC	5.55	6.07	6.98	8.08	8.95	10.55	12.20	13.65	14.06
		Input	0.88	0.84	0.86	0.88	0.95	0.85	1.21	1.55	1.54
		COP	1.86	2.11	2.38	2.69	2.78	3.63	2.96	2.58	2.68
	71.6F (22C)	TC	4.58	5.35	5.95	7.12	7.92	8.94	10.48	11.52	12.38
		Input	0.86	0.79	0.84	0.86	0.93	0.98	1.20	1.54	1.16
		COP	1.56	1.99	2.07	2.42	2.50	2.67	2.57	2.20	3.14
18 (208–230V)	59F (15C)	TC	9.03	10.16	11.43	12.37	13.33	14.90	16.83	18.03	18.59
		Input	2.33	5.12	2.12	5.25	1.92	5.03	1.71	1.61	5.06
		COP	1.14	1.99	1.58	2.36	2.04	2.26	2.88	3.29	3.68
	64.4F (18C)	TC	8.55	10.05	11.95	12.45	13.45	15.65	16.85	18.15	18.17
		Input	2.35	2.25	2.15	2.04	1.94	1.84	1.73	1.63	1.62
		COP	1.07	1.31	1.63	1.79	2.03	2.50	2.85	3.26	3.29
	69F (20.5C)	TC	8.47	9.67	11.87	12.47	13.37	15.57	16.87	18.07	18.09
		Input	2.37	2.27	2.17	2.07	1.96	1.86	1.76	1.65	1.64
		COP	1.05	1.25	1.61	1.77	2.00	2.46	2.82	3.20	3.23
	71.6F (22C)	TC	7.85	8.78	11.25	12.50	13.35	14.74	16.85	18.05	18.18
		Input	2.36	5.02	2.15	5.47	1.95	5.41	1.74	1.64	5.52
		COP	0.98	1.75	1.53	2.29	2.01	2.72	2.84	3.23	3.29
24 (208–230V)	59F (15C)	TC	14.08	16.77	19.76	21.26	23.01	24.12	25.70	26.17	26.60
		Input	2.60	2.88	2.76	2.83	2.62	2.44	2.47	2.33	2.82
		COP	1.59	1.71	2.10	2.10	2.57	2.08	3.05	3.29	3.00
	64.4F (18C)	TC	13.36	15.13	19.00	21.27	22.02	23.36	24.43	25.67	26.69
		Input	2.83	3.08	2.88	2.74	2.68	2.72	2.58	2.43	2.25
		COP	1.38	1.44	1.93	2.27	2.41	2.52	2.78	3.10	3.47
	69F (20.5C)	TC	12.60	14.92	18.50	20.79	21.22	22.45	23.69	24.52	25.29
		Input	2.89	3.17	2.92	2.83	2.77	2.83	2.66	2.52	2.43
		COP	1.28	1.38	1.86	2.15	2.25	2.32	2.61	2.85	3.05
	71.6F (22C)	TC	11.87	15.37	19.07	21.85	22.82	23.37	24.48	25.44	27.45
		Input	2.98	2.75	3.25	2.82	2.95	2.68	2.81	2.88	2.88
		COP	1.17	1.64	1.72	2.27	2.27	2.56	2.55	2.59	2.79

LEGEND
 DB - Dry Bulb
 WB - Wet Bulb
 TC - Total Net Capacity (1000BTU/hour)
 Input - Total Power (kW)
 COP -W/W

APPLICATION DATA

UNIT SELECTION

Select equipment that either matches or supports slightly more than the anticipated peak load. This provides better humidity control, fewer unit cycles, and less part-load operation.

For units used in spaces with high sensible loads, base equipment selection on unit sensible load, not on total anticipated load. Adjust for anticipated room wet bulb temperature to avoid undersizing the equipment.

UNIT MOUNTING (OUTDOOR)

Refer to the unit's installation instructions for further details.

Unit leveling – For reliable operation, units should be level in all planes.

Clearance – Minimum clearance (see Fig. 4) must be provided for airflow. The condensing units are designed for free-flow application. Air inlets and outlets should not be restricted.

Unit location – A location which is convenient to installation and not exposed to strong winds. A location that can bear the weight of the outdoor unit and where the outdoor unit can be mounted in a level position.

Do not install the indoor or outdoor units in a location with special environmental conditions. For those applications, contact your sales representative.

SYSTEM OPERATING CONDITIONS

OPERATING RANGE MIN / MAX °F (°C)		
	COOLING	HEATING
Outdoor DB	0 ~ 122 (-17 ~ 50)	0 ~ 86 (-17 ~ 30)

NOTE: Reference the product installation instructions for more information.

METERING DEVICES

The outdoor unit has an electronic expansion valve to manage the refrigerant flow of the connected fan coil.

DRAIN CONNECTIONS

Install drains to meet the local sanitation codes.

REFRIGERANT LINES

General refrigerant line sizing:

1. The outdoor units are shipped with a full charge of R410A refrigerant. All charges, line sizing, and capacities are based on runs of 25 ft. (7.6 m). For runs over 25 ft. (7.6 m), review the *Long Line Applications* section for the proper charge adjustments.
2. Refrigerant lines should not be buried in the ground. If it is necessary to bury the lines, do not bury more than 36-in (914 mm). Provide a minimum 6-in (152 mm) vertical rise to the service valves to prevent refrigerant migration.
3. Both lines must be insulated. Use a minimum of 1/2-in. (12.7 mm) thick insulation. Closed-cell insulation is recommended in all long-line applications.
4. Special consideration should be given to isolating the interconnecting tubing from the building structure. Isolate the tubing so vibration or noise is not transmitted into the structure.

Long Line Applications:

1. No change in line sizing is required.
2. Add refrigerant per the Additional Charge table.

ADDITIONAL CHARGE							
UNIT SIZE	TOTAL LINE LENGTH ft. (m)		ADDITIONAL CHARGE, oz/ft. FT. (m)				
	Min	Max	10-25 (3-8)	>25-82 (8-25)	>82-98 (25-30)	>98-164 (30-50)	
9	10(3)	82(25)	None	0.16			
12		98(30)			0.16		
18		164(50)			0.32	0.32	0.32
24							

WIRING

All wires must be sized per NEC (National Electrical Code) or CEC (Canadian Electrical Code) and local codes. Use Electrical Data table MCA (minimum circuit amps) and MOCP (maximum over current protection) to correctly size the wires and the disconnect fuse or breakers respectively.

Recommended Connection Method for Power and Communication Wiring:

The main power is supplied to the outdoor unit. The field supplied 14/3 stranded wire with ground with a 600 volt insulation rating, power/communication wiring from the outdoor unit to indoor unit consists of four (4) wires and provides the power for the indoor unit. Two wires are line voltage AC power, one is communication wiring (S) and the other is a ground wire. Wiring between indoor and outdoor unit is polarity sensitive. The use of BX wire is NOT recommended.

If installed in a high Electromagnetic field (EMF) area and communication issues exists, a 14/2 stranded shielded wire can be used to replace L2/N and (S) between outdoor unit and indoor unit landing the shield onto ground in the outdoor unit only.



CAUTION

EQUIPMENT DAMAGE HAZARD

Failure to follow this caution may result in equipment damage or improper operation.

Wires should be sized based on NEC and local codes.



CAUTION

EQUIPMENT DAMAGE HAZARD

Failure to follow this caution may result in equipment damage or improper operation.

Be sure to comply with local codes while running wire from the indoor unit to the outdoor unit.

Every wire must be connected firmly. Loose wiring may cause the terminal to overheat or result in unit malfunction. A fire hazard may also exist. Ensure all wiring is tightly connected.

No wire should touch the refrigerant tubing, compressor or any moving parts.

Disconnecting means must be provided and shall be located within sight and readily accessible from the air conditioner.

Connecting cable with conduit shall be routed through the hole in the conduit panel.

AIR FLOW DATA

COOLING ONLY				
38MHRBC Unit Size	12K (115V)	12K (208/230V)	18K (208/230V)	24K (208/230V)
Outdoor (CFM)	1,170	1,230	1,195	1,825

HEAT PUMP					
38MHRBQ Unit Size	12K (115V)	9K (208/230V)	12K (208/230V)	18K (208/230V)	24K (208/230V)
Outdoor (CFM)	1,170	1,170	1,170	1,170	1,765

SOUND DATA

COOLING ONLY					
38MHRBC Unit Size		12K (115V)	12K (208/230V)	18K (208/230V)	24K (208/230V)
Outdoor Sound Pressure Level	dB(A)	52	53.6	55.3	58
Outdoor Sound Power Level	dB(A)	63.3	63.6	65.3	65.5

HEAT PUMP						
38MHRBQ Unit Size		12K (115V)	9K (208/230V)	12K (208/230V)	18K (208/230V)	24K (208/230V)
Outdoor Sound Pressure Level	dB(A)	54.5	57.2	57.4	57	60.2
Outdoor Sound Power Level	dB(A)	63.5	62.8	64.1	65.7	66.2

SOUND PRESSURE IN OCTAVE BANDS

COOLING ONLY										
	Frequency (Hz)	63	125	250	500	1000	2000	4000	6300	8000
12K(115)	Cooling dB(A)	60.2	57.3	52.0	49.9	45.9	41.1	35.6	30.1	60.2
12K(208V)	Cooling dB(A)	17.47	32.97	38.41	41.03	41.68	38.9	32.81	27.85	25.52
18K(208V)	Cooling dB(A)	22.93	37.81	40.28	45.45	43.52	42.24	32.44	25.5	20.79
24K(208V)	Cooling dB(A)	19.86	37.23	46.54	45.59	45.92	41.09	36.12	30.05	26.86

HEAT PUMP										
	Frequency (Hz)	63	125	250	500	1000	2000	4000	8000	
12K (115)	Cooling dB(A)	52.6	56.9	56.6	53.3	48.7	42.1	37.4	34.0	
	Heating dB(A)	59.9	55.5	54.0	50.6	46.8	42.2	36.1	31.5	
9K (208V)	Cooling dB(A)	59.3	56.9	53.1	50.8	46.4	42.6	36.4	30.3	
	Heating dB(A)	57.8	56.3	55.1	51.7	47.9	44.5	38.7	33.6	
12K (208V)	Cooling dB(A)	64.8	57.3	55.7	53.3	51.1	48.1	42.6	36.1	
	Heating dB(A)	56.8	56.9	57.8	53.2	49.3	44.6	39.2	31.8	
18K (208V)	Cooling dB(A)	54.1	55.8	51.2	48.7	46.8	42.5	34.8	28.3	
	Heating dB(A)	52.9	58.6	51.7	49.9	50.3	43.0	38.5	33.3	
24K (208V)	Cooling dB(A)	52.6	56.9	56.6	53.3	48.7	42.1	37.4	34.0	
	Heating dB(A)	59.9	55.5	54.0	50.6	46.8	42.2	36.1	31.5	

OUTDOOR UNIT SOUND PRESSURE TEST CONDITIONS

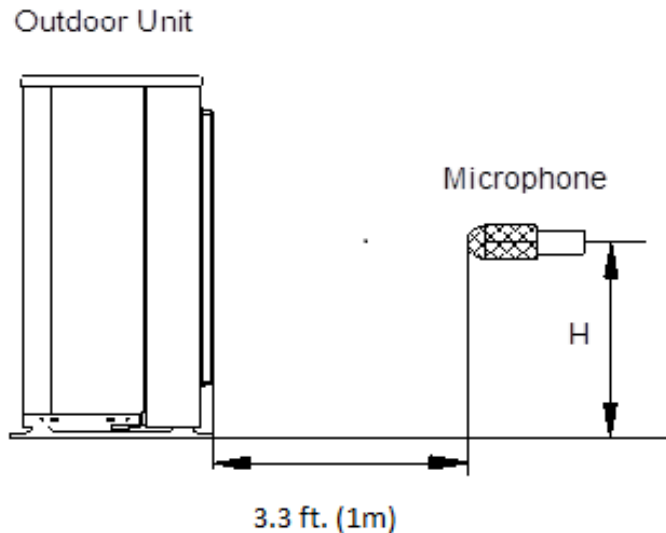

NOTE: $H=0.5 \times$ Height of outdoor unit

	Indoor Condition		Outdoor Condition	
	DB	WB	DB	WB
Cooling	80.6F (27C)	66.2F (19C)	95F (35C)	75.2F (24C)
Heating	68F (20C)	59F (15C)	44.6F (7C)	42.8F (6C)

ELECTRICAL DATA

COOLING ONLY	Outdoor Unit Size	12K	12K	18K	24K
	Volts–PH–Hz	(115V)	(208/230V)	(208/230V)	(208/230V)
	Max – Min* Oper. Voltage	127–104	253–187	253–187	253–187
Power Supply	MCA	13	11	15	18
	MOCP	20	15	20	25
Compressor	RLA	9.5	6.8	9	12
Outdoor Fan Motor	FLA	0.6	0.5	0.6	0.6
	Rated HP	0.054	0.054	0.054	0.068
	Output	40	40	40	50

HEAT PUMP	Outdoor Unit Size	12K	9K	12K	18K	24K
	Volts–PH–Hz	(115V)	(208/230V)	(208/230V)	(208/230V)	(208/230V)
	Max – Min* Oper. Voltage	127–104	253–187	253–187	253–187	253–187
Power Supply	MCA	13	8	10	15	18
	MOCP	20	15	15	20	25
Compressor	RLA	10.5	5.5	6.8	10.5	12
Outdoor Fan Motor	FLA	0.6	0.4	0.4	0.5	0.6
	Rated HP	0.054	0.054	0.054	0.054	0.068
	Output	40	40	40	40	50

*Permissible limits of the voltage range at which the unit will operate satisfactorily.

LEGEND

FLA – Full Load Amps

MCA – Minimum Circuit Amps

MOCP – Maximum Over–Current Protection

RLA – Rated Load Amps

FAN AND MOTOR SPECIFICATIONS

Cooling Only						
38MHRB Unit Size		12K (115V)	12K (208/230V)	18K (208/230V)	24K (208/230V)	
Outdoor fan	Material		Acrylonitrile Styrene +20%GF	Acrylonitrile Styrene +20%GF	Acrylonitrile Styrene +20%GF	Acrylonitrile Styrene +20%GF
	Type	–	ZL–425*127*8–3KN	ZL–425*127*8–3KN	ZL–420*143*8–3KN	ZL–490*151*12–3KN
	Diameter	Inch (mm)	16.73 (425)	16.73 (425)	16.54 (420)	19.29 (490)
	Height	inch	5 (127)	5 (127)	5.63 (143)	5.94 (151)
Outdoor fan motor	Model	–	ZKFN–40–8–1L	ZKFN–40–8–1L	YKT–48–6–206	ZKFN–50–8–2
	Volts	V	115	208/230	208/230	208/230
	Phase	–	1	1	1	1
	Hertz	Hz	60	60	60	60
	FLA	A	0.6	0.5	0.6	0.6
	Rated HP	HP	0.054	0.054	0.054	0.068
	Output	W	40	40	Ø40	50
	Type	–	DC	DC	DC	DC
	Insulation class	–	E	E	E	E
	Safe class	–	IPX4	IPX4	IPX4	IPX4
	Input	W	63	63	63	115
	Range of current	Amps	0.6±10%	0.5±10%	0.6±10%	0.6±10%
	Rated current	Amps	0.6	Ø0.5	Ø0.6	0.6
	Capacitor	µF	N/A	N/A	N/A	N/A
	Speed	rev/min	960/700	850/700	850/700	900/650
	Rated RPM	rev/min	980	980	980	900
Max. input	W	91	91	91	137	

Heat Pump						
38MHRB Unit Size		12K (115V)	9K (208/230V)	12K (208/230V)	18K (208/230V)	24K (208/230V)
Outdoor fan	Material	–	Acrylonitrile Styrene +20%GF	Acrylonitrile Styrene +20%GF	Acrylonitrile Styrene +20%GF	Acrylonitrile Styrene +20%GF
	Type	–	ZL–425*127*8–3KN	ZL–425*127*8–3KN	ZL–425*127*8–3KN	ZL–427*139*8–3KN
	Diameter	inch	16.73 (425)	16.73 (425)	16.73 (425)	16.81 (427)
	Height	inch	5 (127)	5 (127)	5 (127)	5.47 (139)
Outdoor fan motor	Model	–	ZKFN–40–8–1L	ZKFN–40–8–1L	ZKFN–40–8–1L	ZKFN–40–8–1L
	Volts	V	115	208/230	208/230	208/230
	Phase	–	1	1	1	1
	Hertz	Hz	60	60	60	60
	FLA	A	0.6	0.4	0.4	0.5
	Rated HP	HP	0.054	0.054	0.054	0.054
	Output	W	40	40	40	40
	Type	–	DC	DC	DC	DC
	Insulation class	–	E	E	E	E
	Safe class	–	IPX4	IPX4	IPX4	IPX4
	Input	W	63	63	63	63
	Range of current	Amps	0.6±10%	0.4±10%	0.4±10%	0.5±10%
	Rated current	Amps	0.6	0.4	0.4	0.5
	Capacitor	µF	NA	NA	NA	NA
	Speed	rev/min	850/650	850/650	850/650	850/650
	Rated RPM	rev/min	980	980	980	980
Max. input	W	91	91	91	91	

WIRING DIAGRAMS (COOLING ONLY)

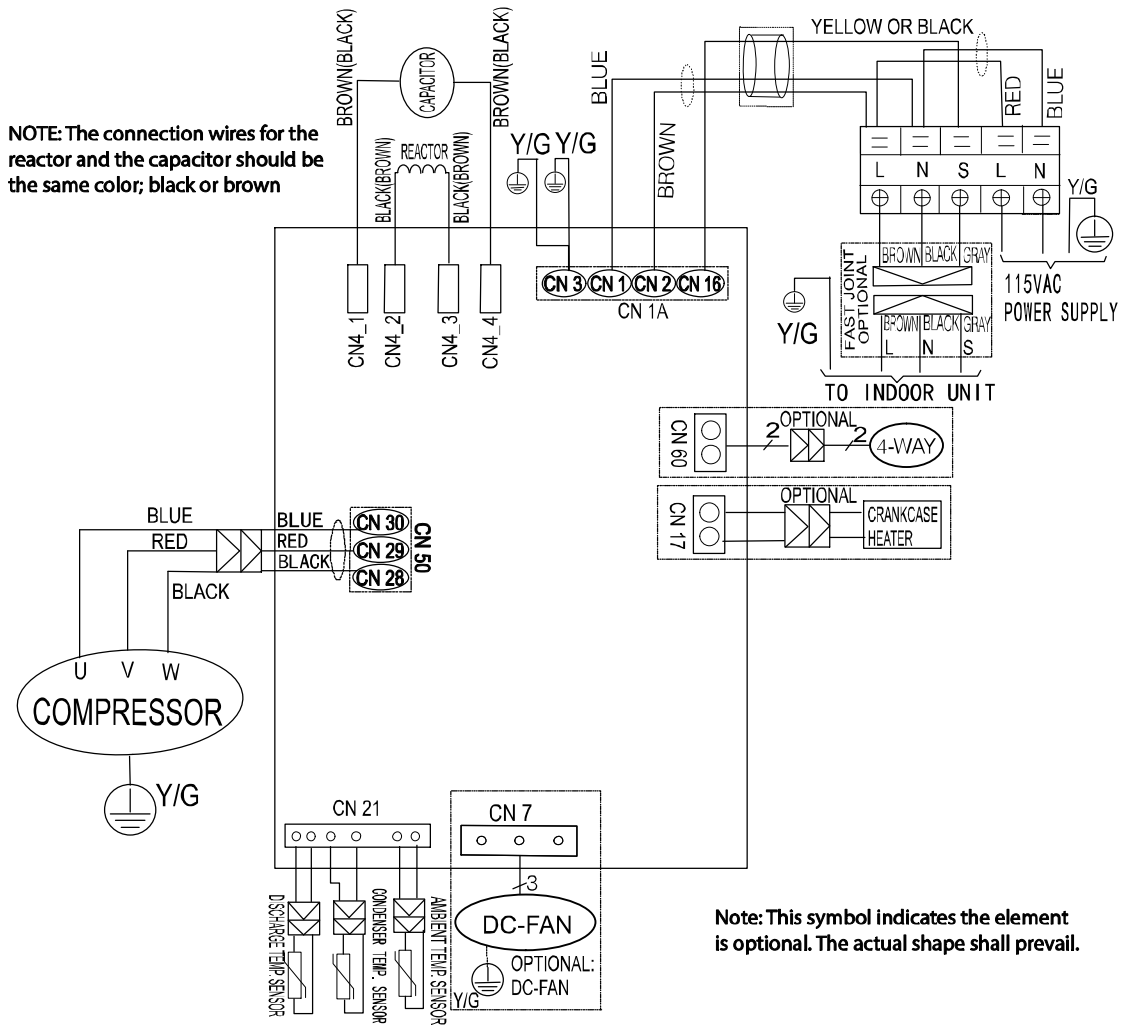

CODE	PART NAME	CODE	PART NAME
CN1A	Input: 115V high voltage connector with L/N/signal/ground	CN21	Input: temperature acquisition (0~5VDC)
CN7	Output: 0~320VDC to control DC FAN		
CN4_1 CN4_2 CN4_3 CN4_4	Output: 115VAC High voltage connector for power factor corrector(PFC)		
CN17	Output: 115VAC to control crankcase heater	CN60	Output: 115 VAC to control 4-way valve
CN50	Output: 0~320V DC to connect compressor		

Fig. 6 – Wiring Diagram Size – Cooling Only Size 12K (115V)

WIRING DIAGRAMS (COOLING ONLY (CONTINUED))

Notes: This symbol indicates the element is optional. The actual shape shall prevail.

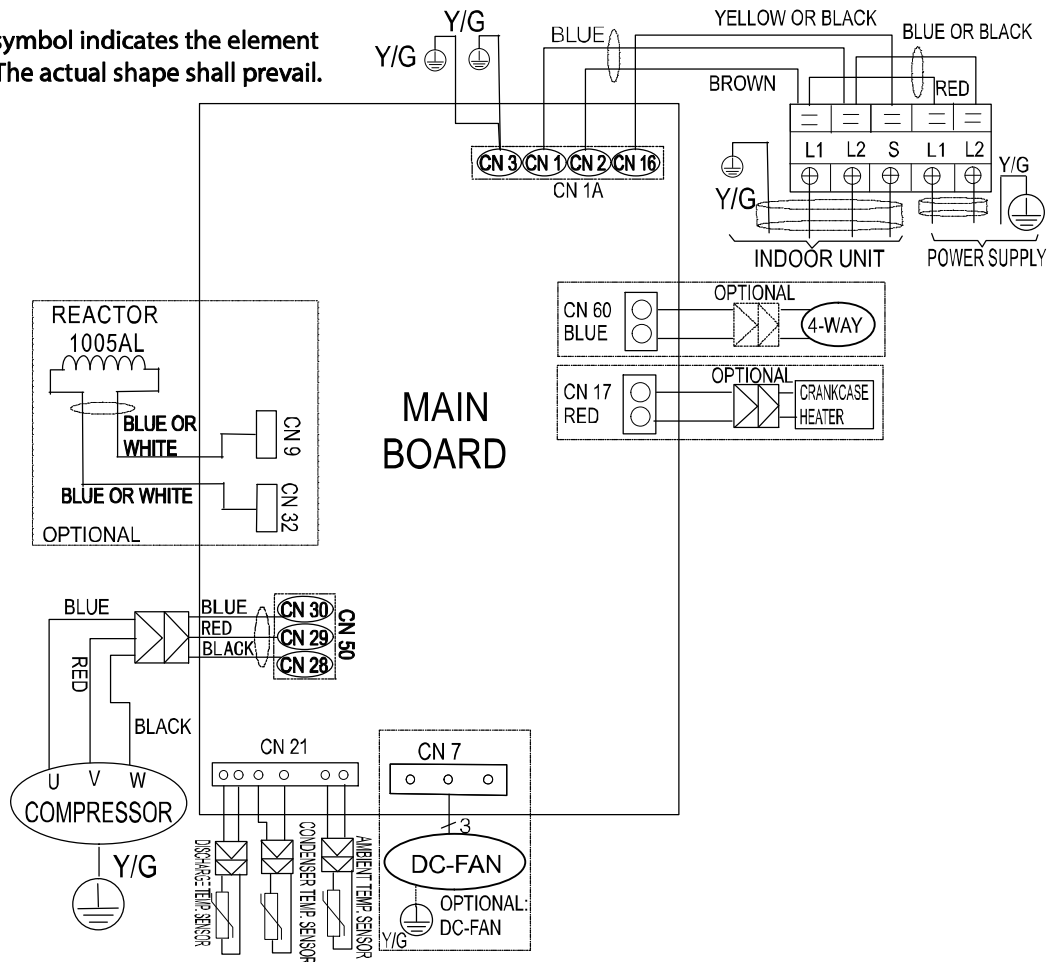

CODE	PART NAME	CODE	PART NAME
CN1A	Input: 220V high voltage connector with L1,L2/signal/ground	GN21	Input: temperature sensor connector (0~5V DC)
GN7	Output: 0~320V DC to connect DC FAN		
CN9~CN32	To connect PFC reactor	CN50	Output: 0~320V DC to connect compressor
CN17	Output: 220V AC to connect crankcase heater	CN60	Output: 0~220V AC to connect 4-way valve

Fig. 7 – Wiring Diagram Cooling Only Size 12K (230V)

WIRING DIAGRAMS (COOLING ONLY (CONTINUED))

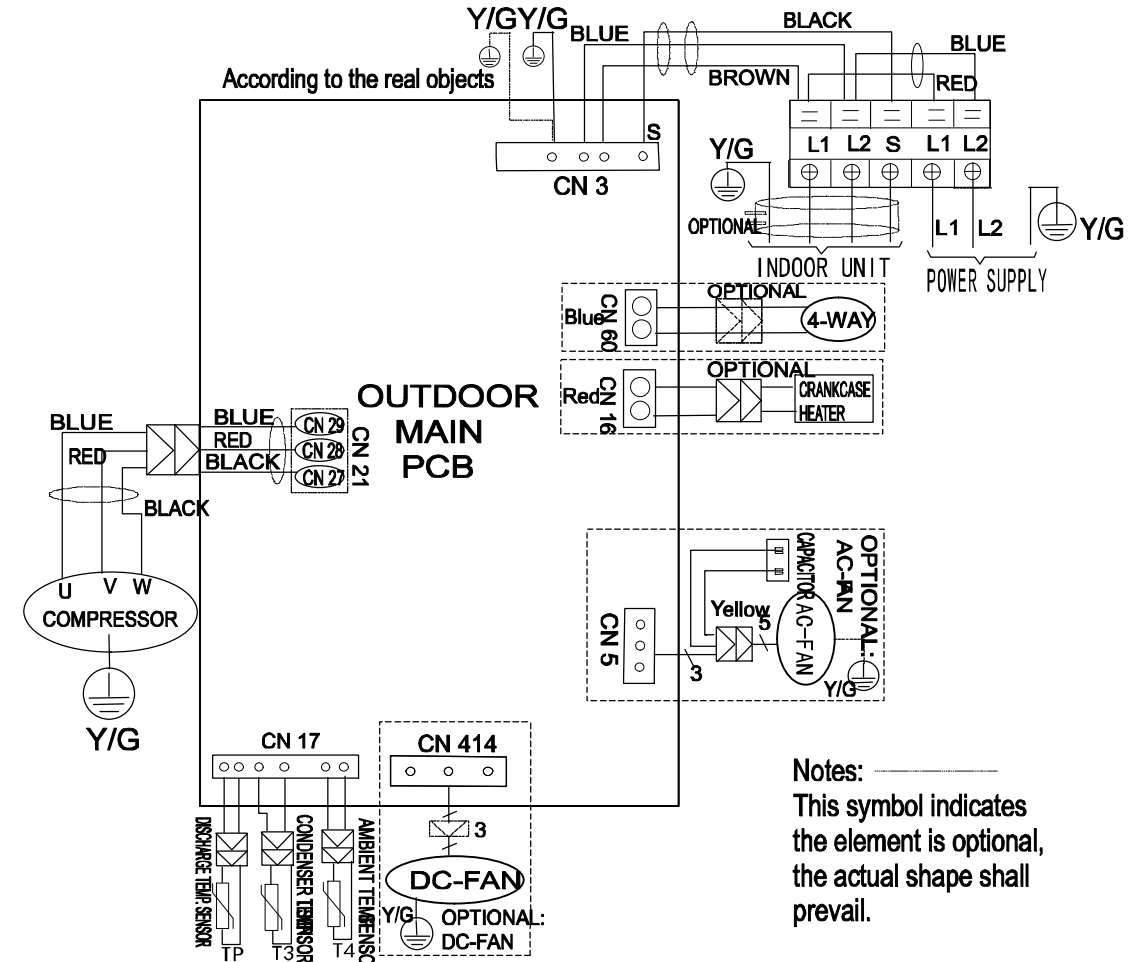

CODE	PART NAME	CODE	PART NAME
CN3	Input: 220V high voltage connector with L1/L2/signal/ground	CN5	Output: 0~220VAC to control AC FAN
CN21	Output: PWM for UVW to control Compressor(0~320VDC)	CN16	Output: 220V AC to control crankcase heater
CN17	Input: Temperature acquisition(0-5VDC)	CN60	Output: 0~220V AC to control 4-way valve
CN414	Output: 0~320VDC to control DC FAN		

Fig. 8 – Wiring Diagram Cooling Only Sizes 18–24K

WIRING DIAGRAMS (HEAT PUMP)

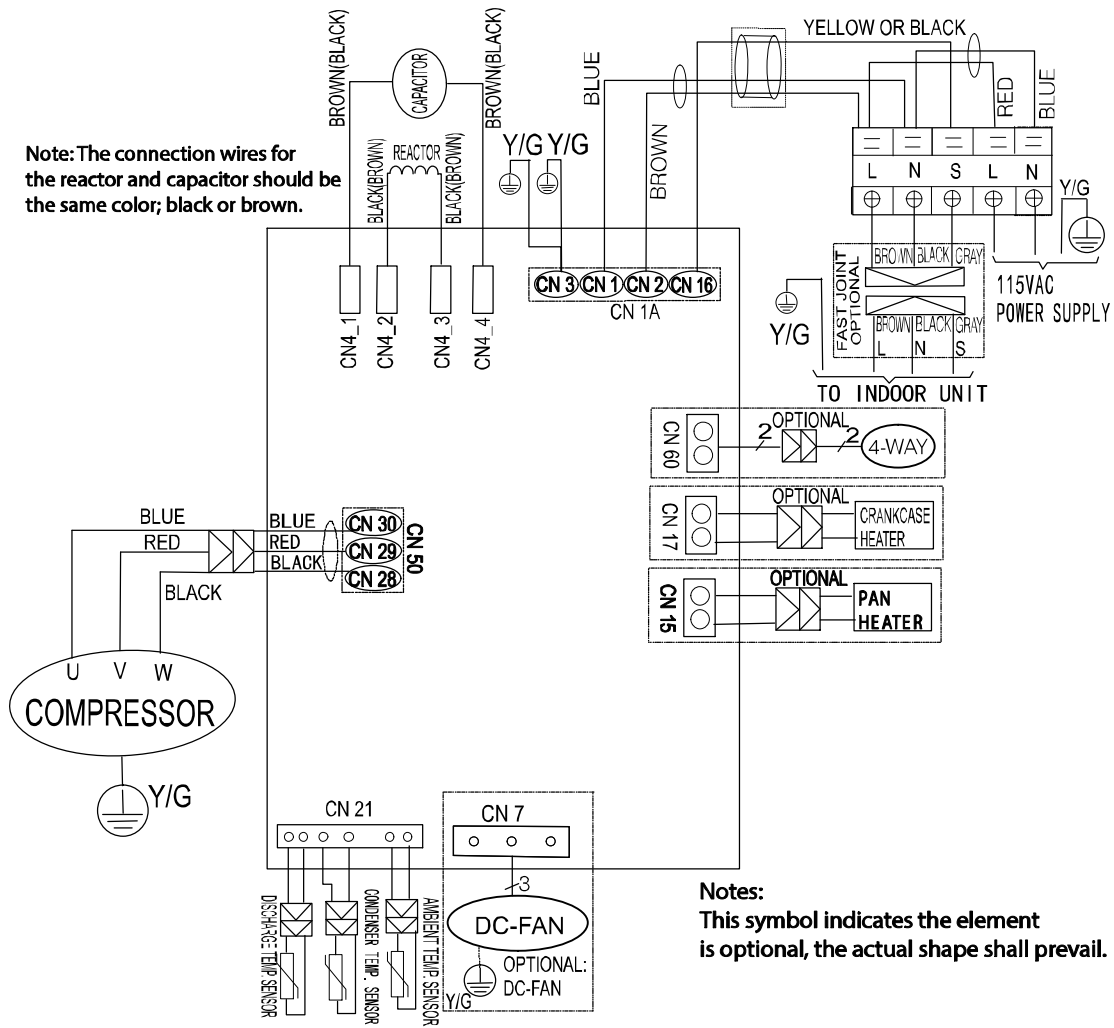

CODE	PART NAME	CODE	PART NAME
CN 1A	Input: 115V high voltage connector with L/N/signal/ground	CN 15	100-130VAC Pan Heater
CN 50	Output: PWM to control Compressor (0~320VDC)	CN 17	Output: 115V AC to control crankcase heater
CN 21	Input: Temperature acquisition(0-5VDC)	CN 60	Output: 0-115V AC to control 4-way valve
CN 7	Output: 0~320VDC to control DC FAN	CN4_1 CN4_2 CN4_3 CN4_4	Output: Connection of the high voltage(REACTOR)

Fig. 9 – Wiring Diagram Heat Pump Size 12K (115V)

WIRING DIAGRAMS (HEAT PUMP (CONTINUED))

Notes: _____
 This symbol indicates the element is optional, the actual shape shall prevail.

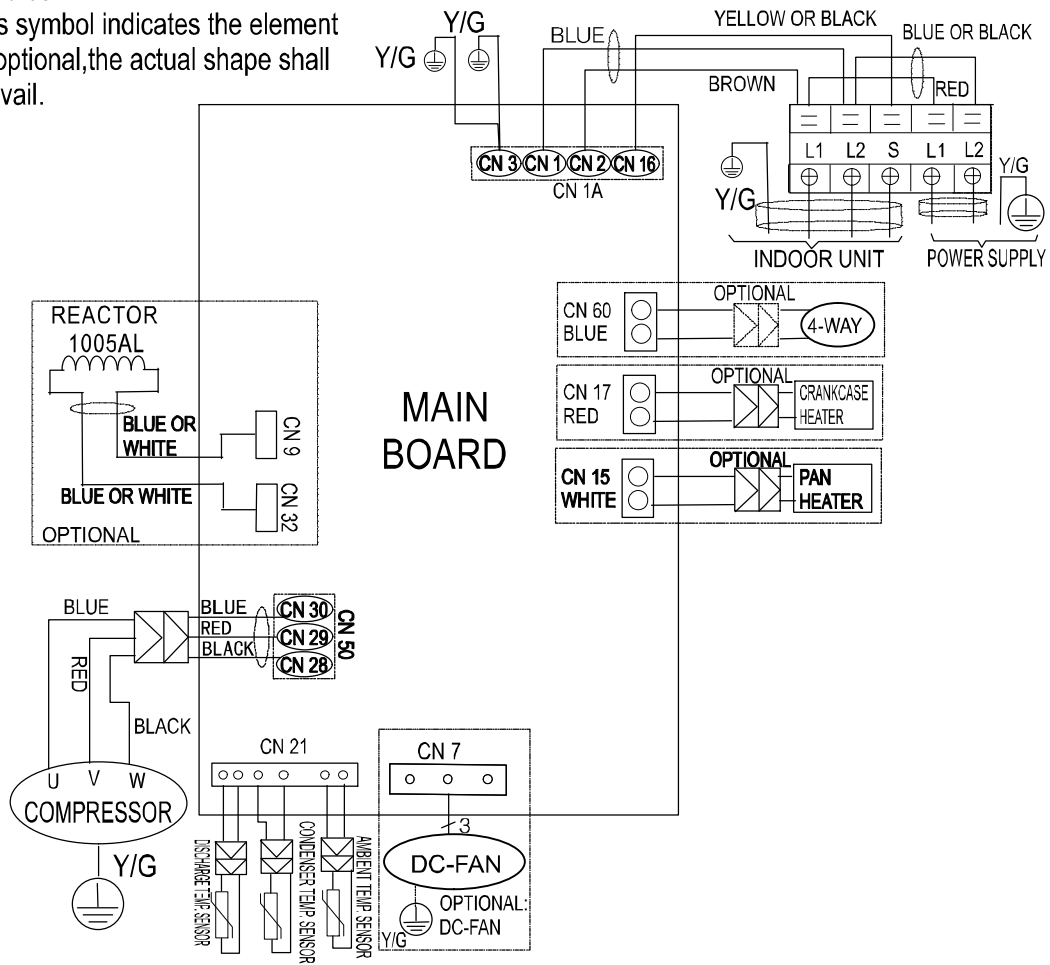

CODE	PART NAME	CODE	PART NAME
CN1A	Input: 220V high voltage connector with L1,L2/signal/ground	CN21	Input: temperature sensor connector (0~5V DC)
CN7	Output: 0~320V DC to connect DC FAN	CN15	220VAC Pan Heater
CN9~CN32	To connect PFC reactor	CN50	Output: 0~320V DC to connect compressor
CN17	Output: 220V AC to connect cranks case heater	CN60	Output: 0~220V AC to connect 4-way valve

Fig. 10 – Wiring Diagram Heat Pump Sizes 09, 12, 18 (230V)

WIRING DIAGRAMS (HEAT PUMP (CONTINUED))

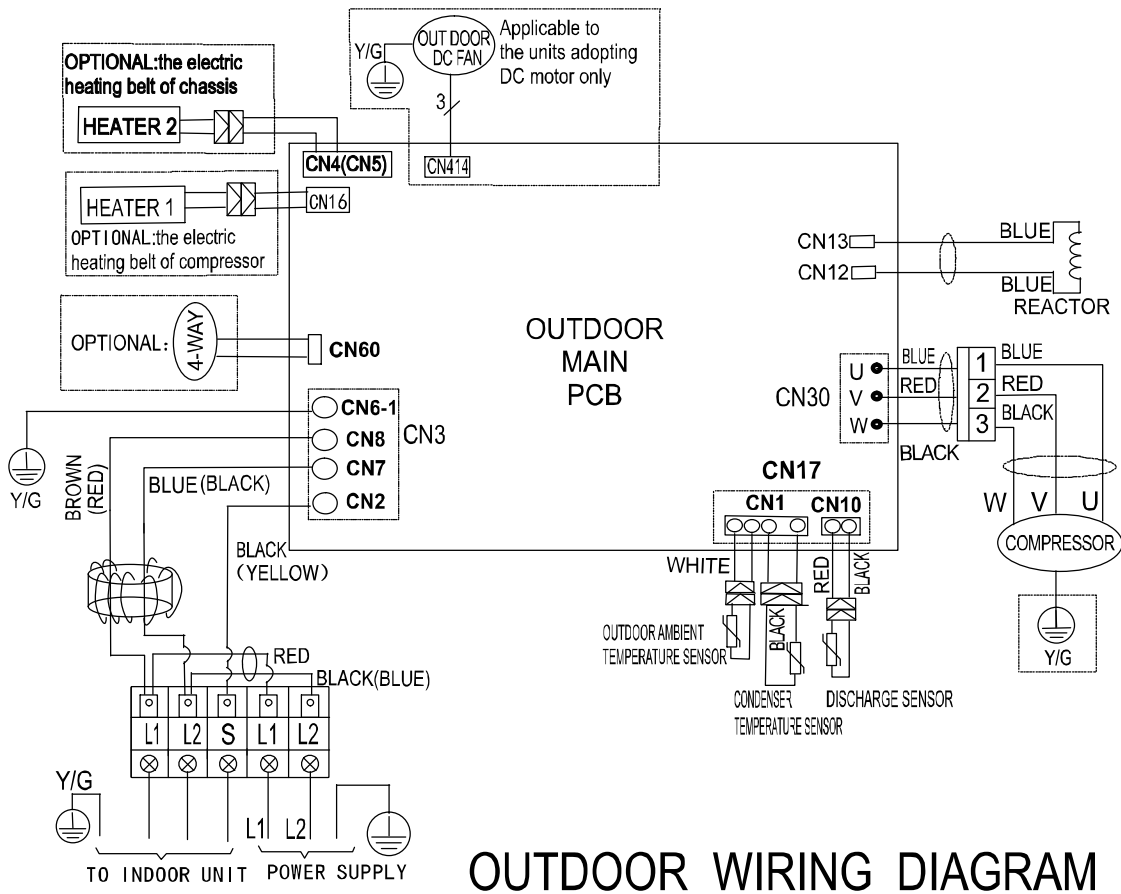

OUTDOOR WIRING DIAGRAM

CODE	PART NAME	CODE	PART NAME
CN414	Output: 0~320VDC to control DC FAN	CN3	Input: 230V high voltage connector with L1/L2/signal/ground
CN4 (CN5)	208-230VAC Base Pan heater	CN17	Input: Temperature acquisition(0-5VDC)
CN16	Output: 220V AC to control crankcase heater	CN30	Output: PWM for UVW to control Compressor(0~320VDC)
CN60	Output: 0~220V AC to control 4-way valve	CN12~CN13	Output: To connect PFC reactor

Fig. 11 – Wiring Diagram Heat Pump Size 24 (230V)

GUIDE SPECIFICATIONS

HORIZONTAL DISCHARGE OUTDOOR UNITS

Size Range: 3/4 to 2 Ton Nominal Cooling and Heating Capacity
Model Number: 38MHRB

PART 1 – GENERAL

1.01 System Description

- A. Outdoor air-cooled split system compressor sections suitable for on-the-ground, rooftop, wall hung or balcony mounting. Units consist of a rotary compressor, an air-cooled coil, propeller-type draw-through outdoor fan, reversing valve (HP), accumulator (HP units), metering device(s), and a control box. Units discharge air horizontally as shown on the contract drawings. Units function as the outdoor component of an air-to-air cooling only, or heat pump system.
- B. Units are to be used in a refrigeration circuit matched to ductless heat pump fan coil units.

1.02 Agency Listings

- A. Unit construction complies with ANSI/ASHRAE 15, latest revision, and with the NEC.
- B. Units are evaluated in accordance with UL standard 1995.
- C. Units are listed in the CEC directory.
- D. Unit cabinet is capable of withstanding 500-hour salt spray test per Federal Test Standard No. 141 (method 6061).
- E. Air-cooled condenser coils are leak tested at 550 psig.

1.03 Delivery, Storage, And Handling

Units are shipped in one piece and are stored and handled per unit manufacturer's recommendations.

1.04 Warranty (For Inclusion By Specifying Engineer)

PART 2 – PRODUCTS

2.01 Equipment

A. General:

Factory assembled, single piece, air-cooled outdoor unit. Contained within the unit enclosure is all the factory wiring, piping, controls, and the compressor.

B. Unit Cabinet:

- 1. Unit cabinet is constructed of galvanized steel, bonderized and coated with a baked-enamel finish on the inside and outside (PANTONE 7527U).
- 2. Unit access panels is removable with minimal screws and provides full access to the compressor, fan, and control components.
- 3. The outdoor compartment is isolated and has an acoustic lining to assure quiet operation.

C. Fans:

- 1. Outdoor fans are the direct drive propeller type, and discharges air horizontally. Fans draw air through the outdoor coil.
- 2. Outdoor fan motors are totally enclosed, single phase motors with class E insulation and permanently lubricated ball bearings. Motor shall be protected by internal thermal overload protection.
- 3. The shaft has inherent corrosion resistance.
- 4. Fan blades are non-metallic and statically and dynamically balanced.
- 5. Outdoor fan openings are equipped with a PVC metal/mesh coated protection grille over the fan.

D. Compressor:

- 1. Compressor is the fully hermetic rotary type.
- 2. Compressor is equipped with an oil system, operating oil charge, and a motor.
- 3. Motor is NEMA rated class E, suitable for operation in a refrigerant atmosphere.
- 4. Compressor assembly is installed on rubber vibration isolators.

E. Outdoor Coil:

The coil is constructed of aluminum golden hydrophilic pre-coated fins mechanically bonded to seamless copper tubes, which are cleaned, dehydrated, and sealed.

F. Refrigeration Components:

Refrigerant circuit components include a brass external liquid line service valve with service gage port connections, a suction line service valve with a service gage connection port, service gage port connections on compressor suction and discharge lines with Schrader type fittings with brass caps, accumulator, reversing valve.

G. Controls and Safeties:

Operating controls and safeties are factory selected, assembled, and tested. The minimum control functions include the following:

- 1. Controls:
 - a. A time delay control sequence is provided standard through the fan coil board
 - b. Automatic outdoor fan motor protection.
- 2. Safeties:
 - a. System diagnostics
 - b. Compressor motor current and temperature overload protection
 - c. Outdoor fan failure protection.

H. Electrical Requirements:

- 1. Unit operates on single-phase, 60 Hz power at 115V for unit sizes 12 and 208/230V for unit sizes 09, 12, 18, and 24 as specified.
- 2. Unit electrical power has a single point connection.
- 3. Unit Control voltage to the indoor fan coil is 0-15V DC.
- 4. All power and control wiring must be installed per NEC and all local electrical codes.
- 5. The unit has high and low voltage terminal block connections.

