



Installation Instructions

Read and become familiar with these instructions before beginning installation.

SAFETY CONSIDERATIONS

Read these instructions thoroughly and follow all warnings or cautions included in the literature and attached to the unit. Consult local building codes and National Electrical Code (NEC) for special requirements. Recognize safety information.

This is the safety-alert symbol . When you see this symbol on the unit and in instructions or manuals, be alert to the potential for personal injury. Understand these signal words: **DANGER**, **WARNING**, and **CAUTION**. These words are used with the safety-alert symbol. **DANGER** identifies the most serious hazards which will result in severe personal injury or death. **WARNING** signifies hazards which could result in personal injury or death. **CAUTION** is used to identify unsafe practices which may result in minor personal injury or product and property damage. **NOTE** is used to highlight suggestions which will result in enhanced installation, reliability, or operation.

 **WARNING**

ELECTRICAL SHOCK HAZARD
Failure to follow this warning could result in personal injury or death. Before beginning any modification or installation of this kit, be sure the main electrical disconnect is in the **OFF** position. Ensure power is disconnected to the fan coil unit. On some systems both the fan coil and the outdoor unit may be on the same disconnect. Tag the disconnect switch with a suitable warning label. There may be more than one disconnect.

 **CAUTION**

EQUIPMENT DAMAGE HAZARD
Failure to follow this warning may result in equipment damage. Do not install the wired controller in an area subjected to excessive steam, oil or sulfide gas. Doing so may cause the controller to deform and/or fail.

 **CAUTION**

INSTALLATION
Entrust the distributor or authorized professionals to install the unit. Installation by unskilled persons may lead to improper installation, electric shock, or fire. Re-installation must be performed by authorized professionals. Non-compliance may lead to electric shock or fire.

TABLE OF CONTENTS

	PAGE
SAFETY CONSIDERATIONS.....	1
OVERVIEW	1
DIMENSIONS.....	2
CLEARANCES	2
INSTALLATION	3
SYSTEM CONFIGURATION SCENARIOS	3
WIRING	8
DIP SWITCHES CONFIGURATION	11
WIRING DIAGRAM	13
APPENDIX 1 - COMPATIBILITY CHART.....	14
APPENDIX 2 - PIPING ADAPTER BUSHINGS/REDUCERS.....	15
APPENDIX 3 - FV4C TRANSFORMER.....	15
APPENDIX 4 - ADDITIONAL REFRIGERANT CHARGE FOR CONVENTIONAL FAN COILS	15
APPENDIX 5 - FV4C AIRFLOW DELIVERY	16

OVERVIEW

The 24V INTERFACE KIT is used to connect:
A Single or Multi-zone Ductless System to a 3rd party single stage conventional thermostat.

A Single Zone Ductless Condensing Unit 38MA*R with an approved Fan Coil. For other applications, consult your Ductless representative.

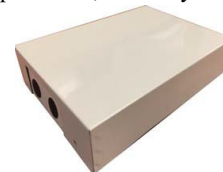

Fig. 1 —24V Interface

NOTES: Images are for illustration purposes only. Actual models may be slightly different.

Table 1 —Kit Contents: Confirm the following parts are included

No.	Description	Qty	Remarks
1	Control box	1	N/A
2	Installation Manual	1	N/A
3	Screws	3	M4X20 (for wall mounting)
4	Wall Anchors	3	For wall mounting
7	Return Air Thermistor Assembly (Hybrid Solutions) (RCD part number 11201007003448)	1	Required and installed near or on the unit and on the air inlet side
8	16ft. (5m) Return Air Thermistor Assembly Extension Wires (RCD part number 17401204010126)	1	For a Return Air Temperature Sensor on Hybrid Solutions

Table 2 — Field Supplied Components: Prepare the following assemblies on site

No.	Description	Qty	Type	Remarks
1	Switch Box	1	N/A	N/A
2	Wiring Tube (insulating sleeve and tightening screw)	1	N/A	N/A



WARNING

The wiring should adapt to the wire control current. Otherwise, electric leakage or overheating may occur and result in a fire.
The specified cables shall be used in the wiring. No external force may be applied to the terminal. Otherwise, the wire may be damaged and heating may occur and result in a fire.



CAUTION

The shielded wire must be grounded. Sensor connecting cable should not be longer than 23ft. (7m). The control box operates on low voltage circuit loops. DO NOT connect a 220V or 380V cable to the circuit loop.

DIMENSIONS

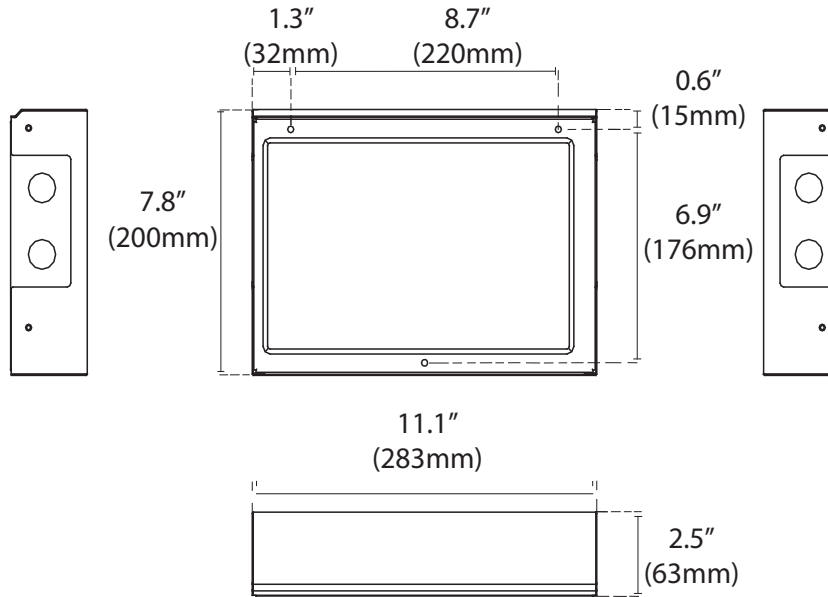

Fig. 2 —24V Interface Structure Size

CLEARANCES

Table 3 — 24V Interface Clearance Dimensions

Clearances	
Unit	Minimum Value In (mm)
Sides	5.9 (150)
Front	24 (610)*
Top and Bottom	3 (76.2)

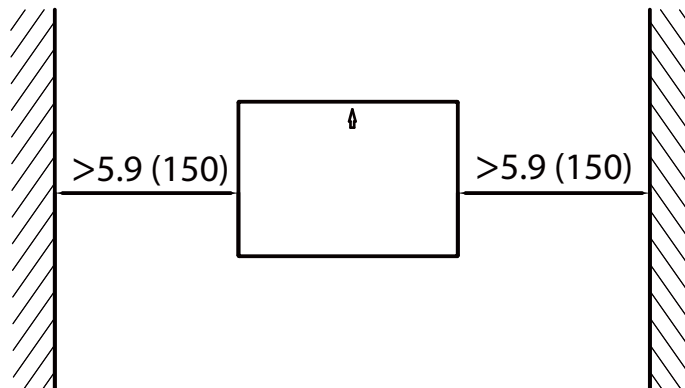

Fig. 3 —Clearances

INSTALLATION

Installation Location

The 24V INTERFACE KIT is rated for outdoor and indoor mounting (depending on the application). It is recommended to install as close as possible to the indoor unit and thermostat.

IMPORTANT: Follow the recommended clearances and install in an area above the ground away from locations where water could enter.

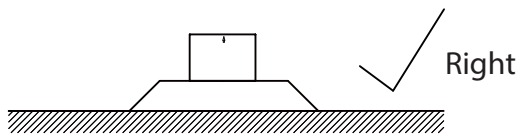

Fig. 4 — Installation Floor Mount View (right way)

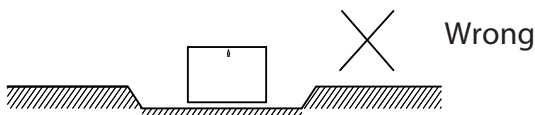

Fig. 5 — Installation Floor Mount View (wrong way)

⚠ CAUTION

DO NOT install the 24V INTERFACE KIT near flammable liquids or gases such as gasoline or hydrogen sulfide. Doing so creates a fire hazard.

1. Remove the cover of the 24V INTERFACE KIT. Remove the six screws of the 24V INTERFACE KIT with a screwdriver or similar tool. Rotate the lid along the hem to disassemble.

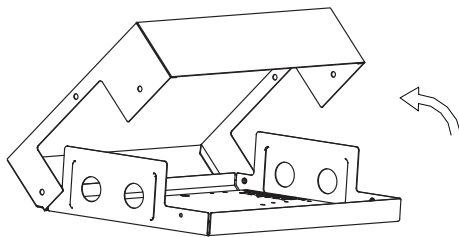

Fig. 6 — Remove the cover

2. Mount the 24V INTERFACE KIT horizontally (see Fig. 7), by fastening the back plate to the wall with 3 screws (M4x20) and anchors.

⚠ CAUTION

The 24V Interface kit cover has a directional arrow on the cover. In case of outdoors installation verify, during the mounting process, that this arrow will point **UP** upon installation. Failure to mount the kit correctly can cause water ingress into the box which may compromise the electrical component integrity.

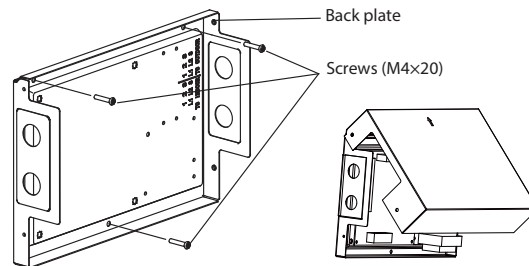

Fig. 7 — 24V Interface Kit

NOTE: Place the unit on a flat surface. Be careful not to distort the back plate of the 24V INTERFACE KIT by over tightening the screws.

3. **WIRING** - Based on the system used, wire the unit as shown in the *System Configuration Scenarios* section.
4. Cover the 24V INTERFACE KIT lid, and lock back in place using the six screws previously removed.

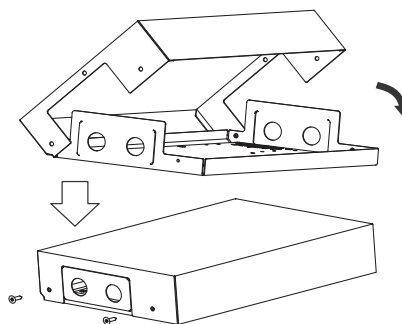

Fig. 8 — Cover the screw

System Configuration

NOTES:

- Thermostat should be configured for use with a conventional system.
- The wireless remote controller, wired controller and Wi-Fi cannot be used with this 24V interface Kit at the same time. Only the Swing and LED function may be accessed with the wireless remote.

Table 4 — Connection Wiring Specification

Connection Wiring	Outdoor L1, L2, S & G, S1, S2	Indoor L1, L2, S & G, S1, S2	R,C	Y/W/G/G1/G2/G3/Dry
Size	Refer to the outdoor connecting wires size	Refer to the indoor connecting wires size	18AWG (minimum)	18AWG (minimum)

SYSTEM CONFIGURATION SCENARIOS

Follow the configuration scenarios for the right connections depending on the system:

- Scenario 1:** Single Zone Ductless System with 38MPRA, 38MA*R, 38MHR
- Scenario 2:** Single Zone Ductless System with 38MBR
- Scenario 3:** Multi-zone Ductless System with 38MGR
- Scenario 4:** Single Zone Fan Coils FMA/FMC/FMU with 38MA*R
- Scenario 5:** Single Zone Fan Coils FV4C with 38MA*R

SYSTEM CONFIGURATION SCENARIOS

Scenario No. 1:

Match the following ductless indoor units with the corresponding compatible **SINGLE ZONE** outdoor units:

- High Wall (sizes 9-36)[208-230V]
- Cassette (sizes 9-24)
- Ducted (sizes 9-24) (*refer to NOTE)
- Console (sizes 18-24)

Installation Steps:

1. Run the interconnecting piping from the indoor to the outdoor unit using the indoor piping size.
2. Run the interconnecting wiring from the outdoor unit to the 24V interface using terminal connections L1, L2, S and G.
3. Run the interconnecting wiring from the 24V interface to the indoor unit using terminal connections L1, L2, S and G.
4. Run the thermostat wiring from the thermostat to the 24V interface using connections R and C on CN15 and Y, W, G on CN19.
5. Configure the dip switches on the 24V interface accordingly.

NOTES:

Follow the Indoor and Outdoor unit's general installation instructions.

*For the Ducted units, in order to initially setup the static pressure, the 24V interface must be bridged. Temporarily connect together the Communication wires L1, L2, S and G from indoor to outdoor unit until static pressure settings are complete (see ducted unit Installation Manual). When static pressure is adjusted, reconnect L1, L2, S and G wires to the terminal blocks.

On selected indoor units, the Up-Down Swing Louver function as well as the control to turn off the indoor unit display (LED) is available on the unit's Wireless Remote controller. The Wi-Fi accessory and Wired Remote controller are not functional when using the 24V interface.

For 115V Ductless applications the 24V transformer must be replaced in the field. This is available through RCD part number 11203103000393.

⚠ CAUTION

The indoor unit requires an updated control board for compatibility with the 24V interface.

Refer to the Compatibility Charts on hvacpartners.com for proper matches and serial number compatibility.

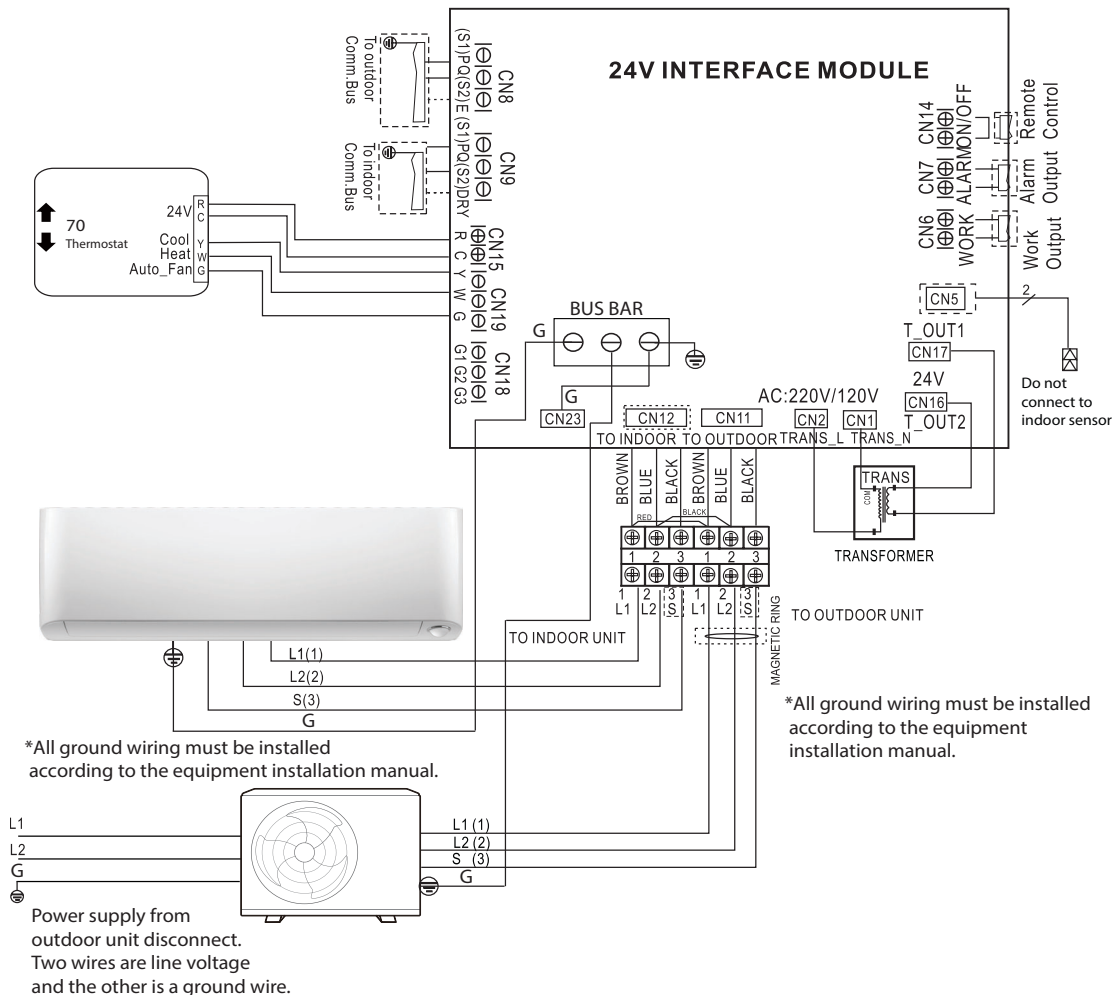

Fig. 9 —Wiring Diagram

IMPORTANT: All ground wiring must be installed according to the equipment installation manual.

Scenario No. 2:

Single Zone Outdoor units 38MBR with approved Ductless indoor units Cassettes, Ducted and Consoles (for proper combinations consult the compatibility chart).

- Cassette (sizes 36-48)
- Ducted (sizes 36-48) (*refer to NOTE)
- Console (sizes 36-48)

Installation Steps:

1. Run the interconnecting piping from the indoor to the outdoor using the indoor piping size.
2. Run the interconnecting wiring from the outdoor unit to the 24V interface using terminal connections L1, L2, and G. Connect the wiring for the S1 & S2 outdoor interface to CN8.
3. Run the interconnecting wiring from the 24V interface to the indoor unit using terminal connections L1, L2, and G. Connect the wiring for S1 & S2 outdoor interface to CN9.
4. Run the thermostat wiring from the thermostat to the 24V interface using connections R and C on CN15 and Y, W, G on CN19.
5. Configure the dip switches on the 24V interface accordingly.

NOTES:

Follow the Indoor and Outdoor unit's general installation instructions.

*For Ducted units, in order to initially setup the static pressure, the 24V interface must be bridged. Temporarily connect together the Communication wires S1 and S2 from indoor to outdoor unit until static pressure settings are complete (see ducted unit Installation Manual). When static pressure is adjusted, connect S1 and S2 to CN8 and CN9 (see Fig. 21).

On selected indoor units, the Up-Down Swing Louver function as well as the control to turn off the indoor unit display is available on the unit's Wireless Remote controller. The Wi-Fi accessory and Wired Remote controller is not functional when using the 24V interface.

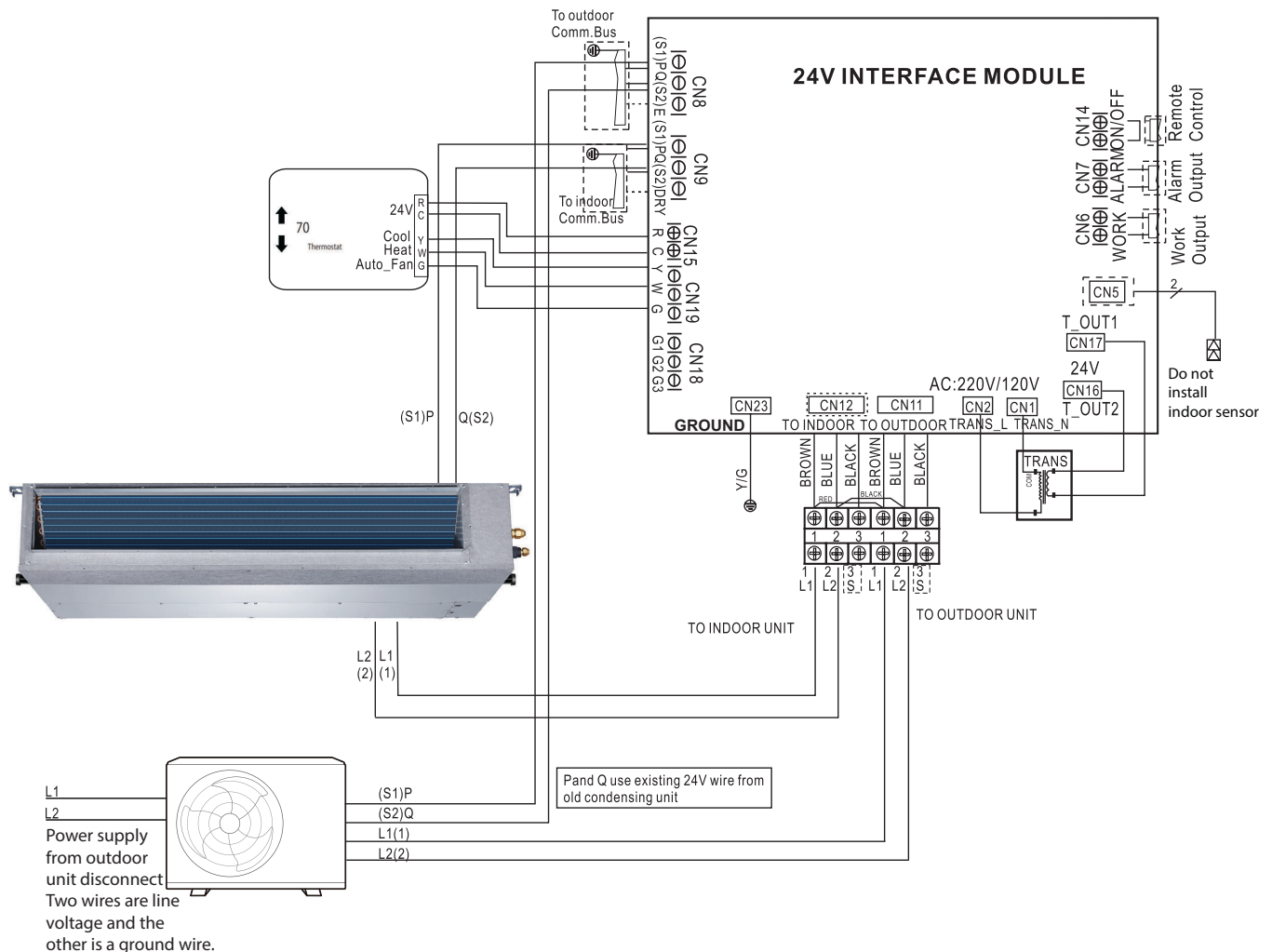

Fig. 10 —Wiring Diagram

Scenario No. 3:

Multi-zone Outdoor units 38MGR with approved Ductless indoor units High Walls, Cassettes, Ducted and Consoles. (For proper combinations, consult the compatibility chart).

- High Wall (Sizes 9-24)
- Cassette (Sizes 9-24)
- Ducted (Sizes 9-24) (*refer to NOTE)
- Console (Sizes 9-24)

Installation Steps:

1. Run interconnecting piping from Indoor to Outdoor using Indoor piping size.
2. Run interconnecting wiring from outdoor unit to 24V interface using terminal connections L1, L2, S, and G.
3. Run interconnecting wiring from 24V interface to indoor unit using terminal connections L1, L2, S and G.
4. Run thermostat wiring from thermostat to 24V interface using connection R and C on CN15 and Y, W, G on CN19.
5. Configure the dip switches on the 24V interface accordingly.

NOTES:

One 24V interface and one thermostat is required per indoor unit head. Follow the Indoor and Outdoor unit's general installation instructions.

***For Ducted units, in order to initially setup the static pressure, the 24V interface must be bridged. Temporarily connect together the Communication wires L1, L2, S and G from indoor to outdoor unit until static pressure settings are complete (see ducted unit Installation Manual). When static pressure is adjusted, reconnect L1, L2, S and G wires to the terminal blocks.**

In the AUTO mode, the system automatically cools or heats the room according to the user-selected set point. mode, the system automatically cools or heats the room according to the user-selected set point.

AUTO mode is recommended for use on Single Zone applications only. Using AUTO changeover on multi-zone applications could set an indoor unit to STANDBY mode, indicated with two dashes (--) on the display, which will turn off the indoor unit until all the indoor units are in the same mode (COOLING or HEATING). HEATING is the system's priority mode. Simultaneous HEATING and COOLING is not allowed.

On selected indoor units, the Up-Down Swing Louver function as well as the control to turn off the indoor unit display, is available on the unit's wireless remote control. The Wi-Fi accessory and wired remote control is not functional when using the 24V interface.

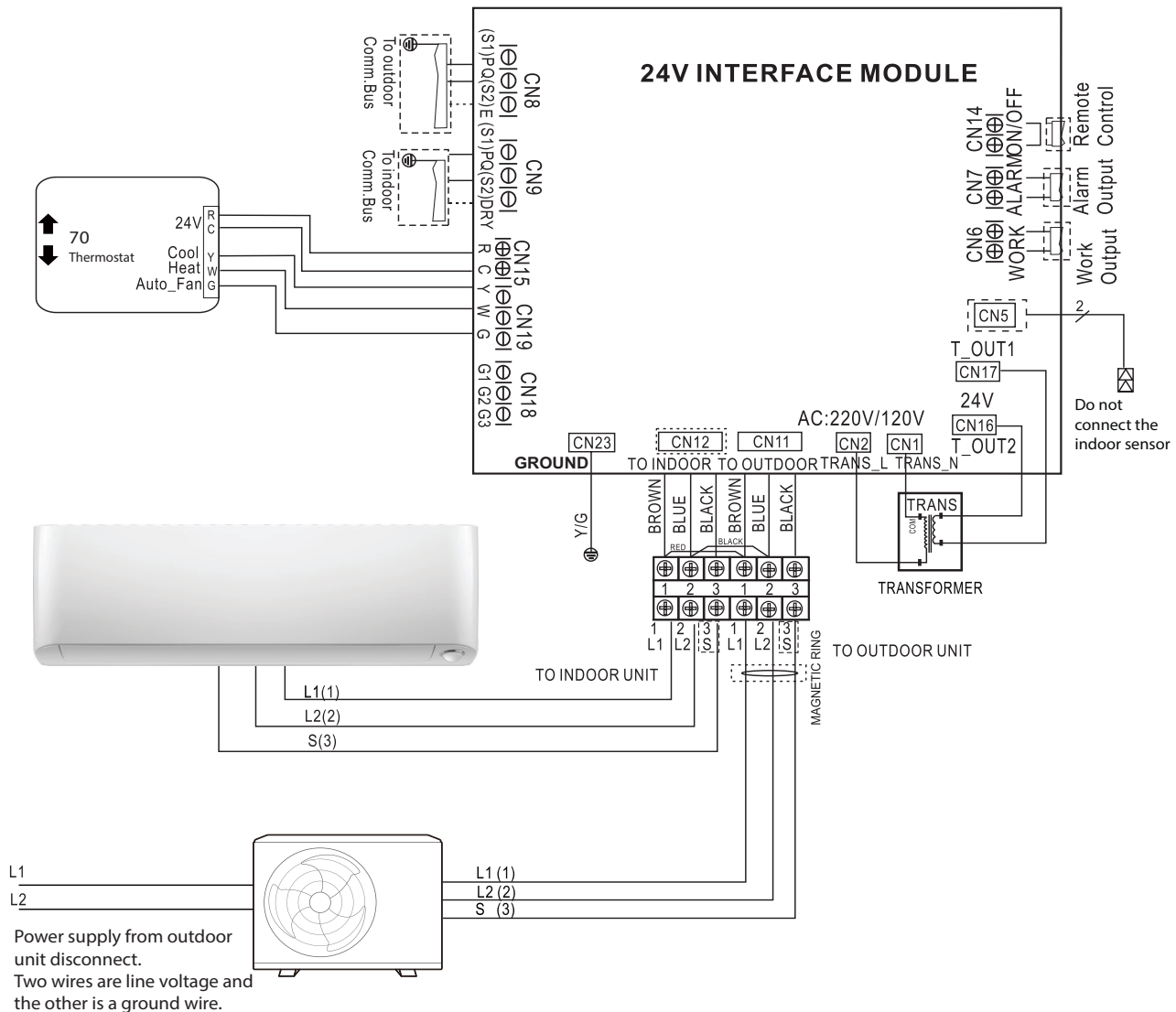

Fig. 11 —Wiring Diagram

Scenario No. 4:

Single Zone outdoor unit 38MA*R with approved multi-family 24V fan coils FMA/FMC/FMU. (For proper combinations consult the compatibility chart in the “APPENDIX 1 - COMPATIBILITY CHART” on page 14).

Installation Steps:

1. Remove TXV/Piston on the indoor unit.
2. Run interconnecting piping from outdoor to indoor using Outdoor piping size and brazing to the adapter for the mechanical fitting from which the TXV was removed (Part number 331831-701) (available through RCD). If required, use the Bushing / Reducers listed on “APPENDIX 2 - PIPING ADAPTER BUSHINGS/ REDUCERS” on page 15.
3. Suction and liquid refrigerant lines must be properly insulated and separated from each other to prevent condensation and energy loss.
4. Disconnect and remove the 24V transformer from the 24V interface kit. Run 2-conductor wire from 24 volt side of the Indoor Unit transformer to CN16 and CN17.
5. Run interconnecting wiring from outdoor unit to 24V interface using terminal connections L1, L2, S and G.
6. Run thermostat wiring from thermostat to 24V interface using connection R and C on CN15 and Y, W, G on CN19.
7. Run thermostat wiring from 24V interface to indoor unit using output connections G1 (Low), G1+G2 (Medium), G1+G2+G3

(High) on the 24V interface and connect according to the installation manual for these fan coils.

8. Install the T1 sensor on CN5 on the 24V interface and place on the return of the indoor unit.

9. Configure the dip switches on the 24V interface accordingly.

NOTES: Follow the Indoor and Outdoor unit's general installation instructions.

The T1 (Return air temperature) sensor should be near or on the unit and on the air inlet side. The thermistor should be installed pointing down into the duct between 2.5ft. (0.762m) and 4ft. (1.2m) from the return side of the fan coil. Use a 1/2” drill and insert the thermistor no less than 6 in. into the duct and seal air tight around cable.

⚠ CAUTION

When the outdoor unit is matched with a Multi-Family or Residential Fan Coil and due the need to braze the piping on the fan coil side it is **REQUIRED** to flow Nitrogen in the system while brazing the line set since a filter drier is not recommended to be used with these condensing units.

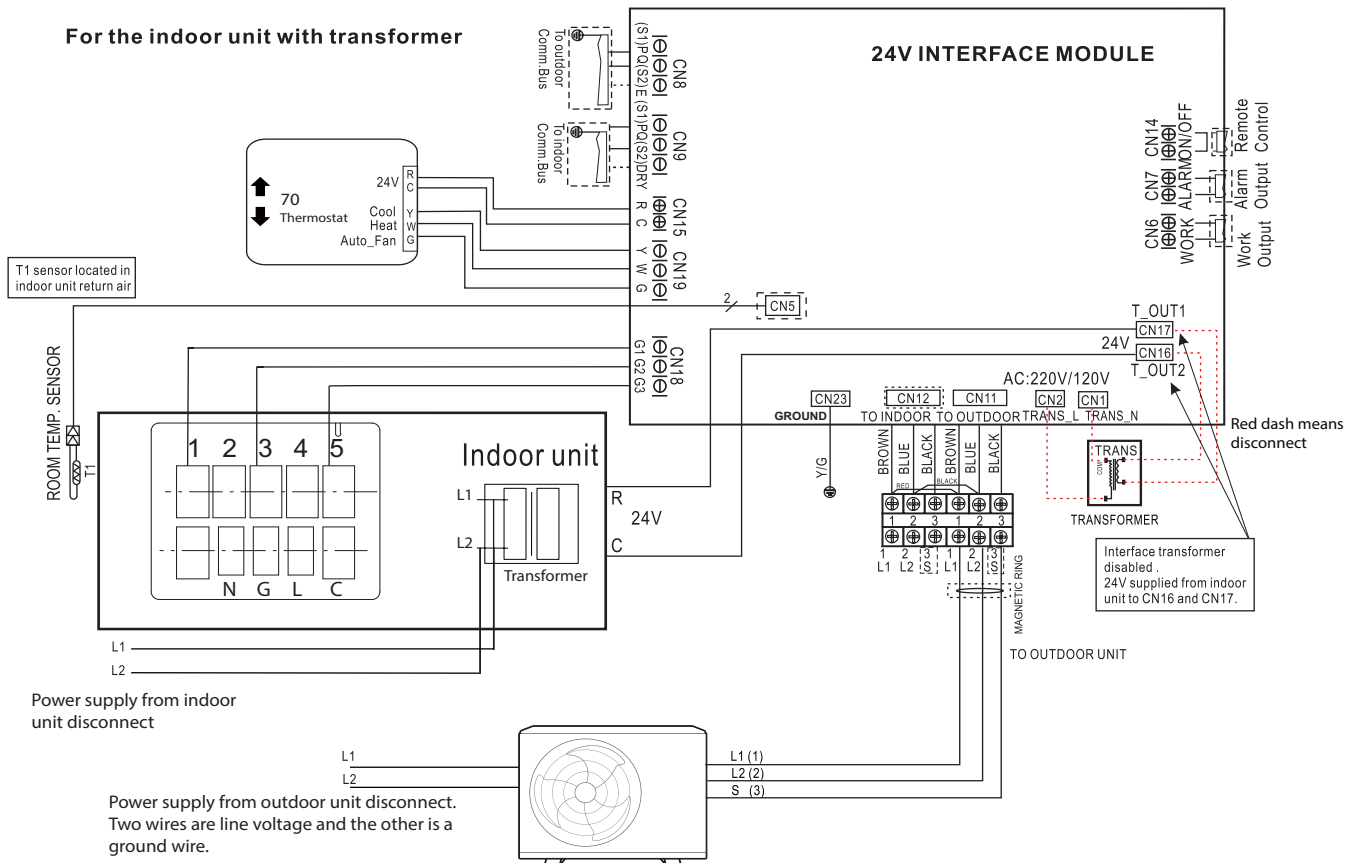

Fig. 12 —Wiring Diagram for Conventional 24V Fan Coil indoor unit

Scenario No. 4 (cont):

WIRING

All wires must be sized per NEC (National Electrical Code) or CEC (Canadian Electrical Code) and local codes. Use Electrical Data table MCA (minimum circuit amps) and MOCP (maximum over current protection) to correctly size the wires and the disconnect fuse or breakers respectively.

Per the caution note, only stranded copper conductors with a 600 volt insulation rating wire must be used. Separate power supplies are required for the OUTDOOR UNIT and the INDOOR UNIT.

The field supplied 14/3 stranded wire with ground and a 600 volt insulation rating, power/communication wiring from the OUTDOOR UNIT to 24V INTERFACE KIT consists of four (4) wires and provides the power for the 24V Interface. Two wires are line voltage AC power, one is communication wiring (S) and the other is a ground wire. Wiring between the OUTDOOR UNIT to 24V INTERFACE KIT is polarity sensitive. The use of B X wire is **NOT** recommended.

Auxiliary Heating: To energize an Auxiliary Heater, connect W2 on the thermostat directly to the an electric heat relay(s) (field supplied) and complete the circuit to the heater element(s).

The thermostat must be setup to use different heating priorities.



CAUTION

The conventional thermostat must be configured for use with a single stage air conditioner (Y output **ONLY**) and a single stage heating (W) system.

Key Considerations

The following steps should be taken when using this device with a conventional central air conditioning unit:

- Indoor coil metering device (TXV/Piston) must be removed
- 24V transformer in the interface module must be disconnected
- Refrigerant charge amount may need to be adjusted, depending on the pipe size and length, see the outdoor recharge instruction.
- The maximum air flow should not exceed 400 CFM/Ton.

When the indoor air handler or furnace has its own 24VAC transformer, you must disconnect all four wires of the 24V Interface kit transformer (see Fig. 13).

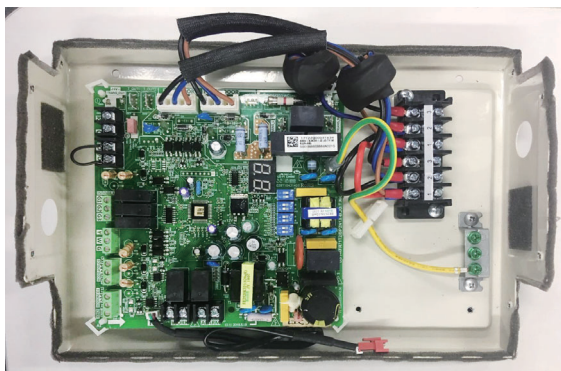

Fig. 13 —Wiring

Control Logic

Table 5 — Conventional Thermostat Connections

Connector	Purpose
R/C	24VAC Output
Y	Cooling
W	Heating
G	Fan
AUX/DRY	Aux/Dry Mode

Table 6 — Mode Setting

Y	W	G	Aux/Dry	Setting Mode
√	X	☆	☆	Cooling
X	√	☆	X	Heating
X	X	√	X	Fan only
√	√	☆	☆	OFF
X	X	X	X	OFF
X	X	☆	√	DRY Mode (on Ductless Systems)

FAN SPEED - Select Auto, Low Medium or High Airflow

For Ductless Systems (Scenarios 1-3) the Fan Speed defaults to **AUTO**. For Hybrid Solutions, see “Scenario No. 4:” on page 7. The fan outputs are **G1 (1st)**, **G1+G2 (2nd)**, and **G1+G2+G3 (3rd)**. For the single fan speed only, **G1** has to be connected.

Use the selection options provided to adjust the airflow supplied to meet the individual installation needs for such things as noise, comfort, and humidity removal.

Table 7 — Fan Speed Setting

Unit ON/OFF	G	Setting Fan Speed
√	X	Auto Fan Speed
√	√	Auto Fan Speed
X	X	Fan OFF

LEGEND

√	ON
X	OFF
☆	ON or OFF



CAUTION

Only the approved combinations and model numbers of the fan coils listed on the Appendix shall be used to avoid any damages to the fan motor.

The use of a fan coils with a PSC motor is not recommended or approved.

TXV Replacement Process for Piping Adapter

For FV4CNF002L00 and FV4CN(B,F)003L (Refer to Fig. 15)

1. Gain access to the Built-in TXV inside the Fan Coil Cabinet.
2. Double-wrench the TXV mechanical connector and disassemble.
3. Cut the bleed line from the TXV to the suction line and braze closed the capillary tube.
4. Remove the tail bulb from the suction line by cutting the stainless steel band.
5. Assemble the line set to the Piping adapter kit (331831-701 obtain through RCD).
 - a. Use “3/8” copper sweat long radius street elbow and “3/8” copper sweat coupling (field supplied).
 - b. Field fabricate “3/8” copper tubing by cutting “3 3/4” length.
 - c. Temporarily remove the Teflon gasket from the tip of the piping adapter.
6. Place Teflon gasket on the brass tip of the Piping Adapter and insert into the aluminum distributor head.
- d. Ensure the brass nut is properly positioned on the adapter before brazing.
- e. Flow Nitrogen for brazing.
- f. Braze the street elbow, tubing and coupling (see Figure 16) to complete the piping adapter.
- g. Refer to Appendix 2 for Bushing/Reducer sizing.
- h. Adapt (where needed) and braze the liquid line to the piping adapter.
- i. Alternate for steps “A”, “B”, and “F”: Use a tubing bender to bend the end of the “3/8” liquid line, cut the tip so that the bend length is “1 3/4” from the outer edge of the tubing (see Figure 17).

Thread piping adapter brass nut onto the distributor line and tighten - finger tight + 1/2 turn.

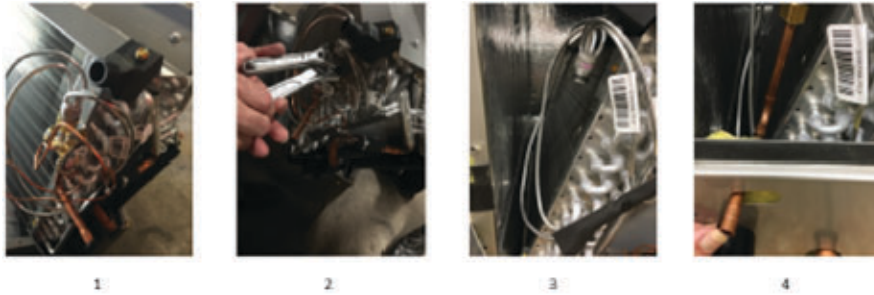

Fig. 15 —Piping Adapter Replacement



Fig. 16 — Braze Street Elbow

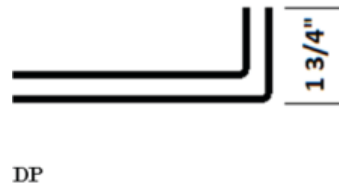

Fig. 17 — Bend Liquid Line

Basic Setup for the FV4C “EASY SELECT” Printed-Circuit Board

BASIC FAN COIL CONFIGURATION

The following basic configuration of the fan coil will provide AHRI rated performance of the heat pump:

- A. AUX HEAT KW/CFM – Select the heater range for the size electric heater installed.
- B. AC/HP SIZE – Select system size installed.
For size 12K select 018 on the board
For sizes 18 - 36 select the nominal connector on the board.
- C. SYSTEM TYPE - Select system type
- D. AC/HP CFM ADJUST – Select NOM.
- E. ON/OFF DELAY – Select 0/90 profile.
- F. CONTINUOUS FAN – Select desired fan speed when thermostat is set to continuous fan.
For size 12K select “MED”

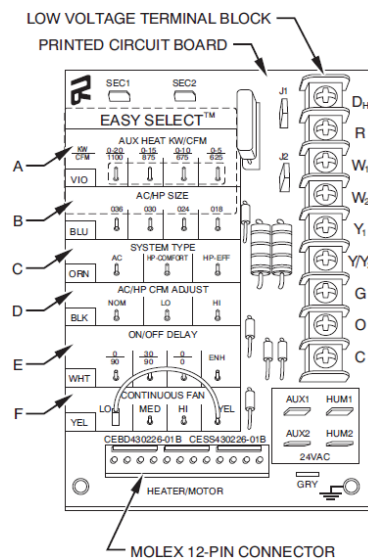

Fig. 18 — Detail of FV4C Printed-Circuit Board

DIP SWITCHES CONFIGURATION

The 24V INTERFACE KIT must be configured to operate properly with the system components with which it is installed. To successfully configure the system, move the Dip Switches to match the components and functions used.

NOTE: Properly identify the DIP switch number marked on the board of the 24V interface as SW1 through SW4 before selecting the options. On each DIP switch block the numbers 1 and 2 would be marked.

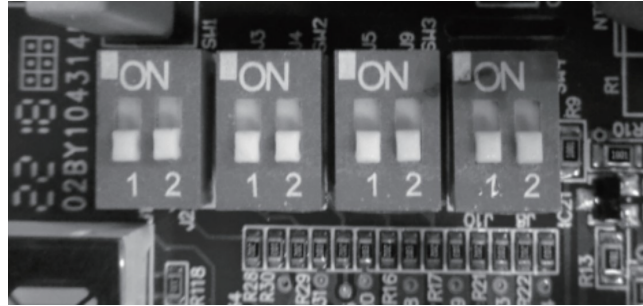

Fig. 19 —DIP Switch Definitions

DIP Switch 1-1

Used to turn ON or OFF the diagnostic code display LED on the control board of the 24V Interface (see Fig. 20).

Table 8 — DIP Switch 1-1

SW1-1	Result	Note
ON	Display on	
OFF	Display off	Default



Fig. 20 —LED

DIP Switch 1-2

Used for selection of the indoor unit type.

Table 9 — DIP Switch 1-2

SW1-2	Result	Note
ON	Sets - Both Ductless Indoor and Outdoor Units (For Scenarios 1-3)	
OFF	Outdoor only (Hybrid Solution) (For Scenario 4) ----- Compatible with other 24V indoor units Fan Coil/Furnace/Cased Coil.	Default (see NOTES* below)

NOTES*:

1. Need to remove the indoor unit throttle (piston/TXV/ orifice);
2. Indoor fan will stop during defrost and will start again 30 seconds after the defrost cycle is complete on the outdoor unit. G1, G2 and G3 on the 24V interface will not provide any fan output signal to the Indoor Fan during the defrost cycle plus 30 seconds.

NOTE: If this 24V interface is matched with Non-Ductless indoor unit, the DIP switch must be set to OFF.

DIP Switch 2-1

Used for selection of the system: **Cooling Only** or **Heat Pump**.

Table 10 — DIP Switch 2-1

SW2-1	Result	Note
ON	Cooling Only	
OFF	Heat Pump	Default

DIP Switch 2-2

Used for freeze protection of the indoor coil (only available on Scenarios 1 through 3).

Table 11 — DIP Switch 2-2

SW2-2	Result	Note
ON	Fan does not stop	
OFF	Fan will stop if the indoor coil temperature is low	Default

NOTE: Applicable only to Ductless Style Indoor Heat Pump units in Heating Mode.

DIP Switch 3-1

On Ductless Systems, **Dry** is used with thermostats with a **Dry Function** output.

Table 12 — DIP Switch 3-1

SW3-1	Result	Note
ON	Dry Mode	
OFF	Used on future applications	Default

DIP Switch 3-2

Used to increase the compressor frequency in case the set point has not been reached after 1 hour or 3 hours of operation. The unit will keep operating as Variable Speed on both cases.

Table 13 — DIP Switch 3-2

SW3-2	Result	Note
ON	1h	
OFF	3h	Default

DIP Switch 4-1

Not required. Used on future applications. Select the indoor unit's fan only mode.

Table 14 — DIP Switch 4-1

SW4-1	Result	Note
ON	The SW4-2 is available under fan only mode	
OFF	The SW1-2 is available	Default

DIP Switch 4-2

Not required. Used on future applications. Select the indoor unit's fan speed (when selecting DIP switch 4-1).

Table 15 — DIP Switch 4-2

SW4-2	Result	Note
ON	Medium fan speed	
OFF	High fan speed	Default

NOTE: If the SW4-1 is ON, the SW4-2 takes effect, otherwise the SW1-2 takes effect.

ERROR CODES

For ease of service, the 24V Interface is equipped with a diagnostic code display LED on the control board (ensure the 24V interface is installed with the directional arrow pointing up to successfully read the error code). Refer to the indoor or outdoor unit's service manual as listed in Table 16 for a troubleshooting breakdown.

Table 16 — Error Codes

Display	Malfunction and Protection Indication	Service Manual Reference
E0	Indoor EEPROM error	Indoor Service Manual
E2	Cross-zero detection error	Indoor or Outdoor Service Manual
E3	Indoor fan speed malfunction	Indoor Service Manual
E4	Indoor room temperature sensor error	Indoor Service Manual
E5	Evaporator coil temperature sensor error	Indoor Service Manual
EC	Refrigerant leak detection system malfunction	Indoor or Outdoor Service Manual
F0	Current overload protection	Outdoor Service Manual
F1	Outdoor ambient temperature sensor (T4) malfunction	Outdoor Service Manual
F2	Condenser coil temperature sensor (T3) malfunction	Outdoor Service Manual
F3	Condenser coil temperature sensor (T5) malfunction	Outdoor Service Manual
F4	Outdoor unit EEPROM parameter error	Outdoor Service Manual
F5	Outdoor fan speed has been out of control	Outdoor Service Manual
F6	T2b sensor error	Indoor or Outdoor Service Manual
P0	Inverter module (IPM) malfunction	Outdoor Service Manual
P1	Over-voltage or under-voltage protection	Outdoor Service Manual
P2	Compressor top high temperature protection (OLP)	Outdoor Service Manual
P3	Low ambient temperature cut off in heating	Outdoor Service Manual
P4	Compressor drive malfunction	Outdoor Service Manual
--	Mode conflict	Indoor Service Manual
P6	Compressor low-pressure protection	Outdoor Service Manual
in	24V Interface and indoor unit communication malfunction	Indoor Service Manual (E1)
ou	24V Interface (indoor unit) and outdoor unit communication malfunction	Indoor Service Manual (E1)
00	24V Interface successful power up and in standby	Operational Code
01	System operating in cooling mode	Operational Code
02	System operating in heating mode	Operational Code
03	System operating in fan mode	Operational Code
04	System operating in dehumidify mode (not a recommended application for FV4C units)	Operational Code
05	System operating with Auxiliary heater active (not a recommended application)	Operational Code

WIRING DIAGRAM

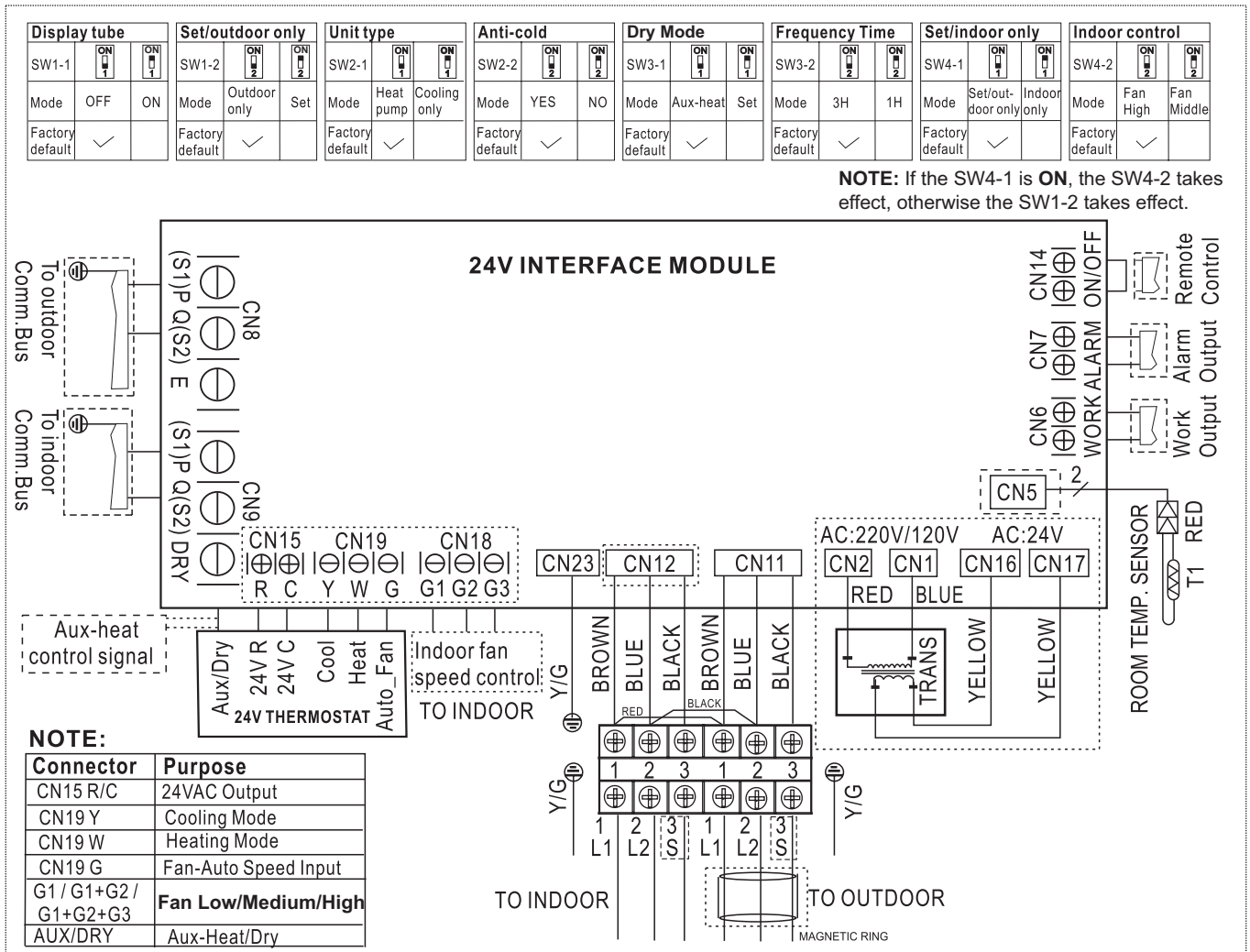

Fig. 21 —Wiring Diagram

GLOSSARY:

- **Remote Control (CN14):** This is a dry contact to control the indoor unit on and off remotely.
- **Alarm Output (CN7):** This is a dry contact that opens and closes based on the alarm status of the system. This is a normally closed Dry contact.
- **Work Output (CN6):** This contact is a dry contact that open and closes based on the system running or not running condition. When the compressor is active this contact closes.

FAN OUTPUTS:

- **(G1) Low Fan Speed**
- **(G1 + G2) Medium Fan Speed**
- **(G1+ G2 + G3) High Fan Speed**

For single fan speed only, G1 has to be connected.

APPENDIX 1 - COMPATIBILITY CHART

The 24V INTERFACE KIT is compatible with most thermostats matched with the Fan Coils listed in Tables 17, 18, and 19. Before installation, check the compatibility of your Outdoor and Indoor Fan Coil. Professional installation is recommended.

Select Proper Blower Speed For the Fan Coil

Before operating unit, ensure that the proper blower speed has been selected. Fan speeds are selected manually. Refer to the installation manual of the indoor unit for instructions on how to change the fan speed and select the taps (see Tables 17, 18, and 19) for the proper matches.

24V Interface Fan Speed Wiring (See Page 9 for Wiring Connections)

G3 is the High Fan Speed terminal and should be connected to the High tap speed inputs at the fan coil.

G2 is the Medium Fan Speed terminal and should be connected to the Medium tap speed inputs at the fan coil.

Tap G1 is Low Fan Speed terminal and should be connected to the Low tap speed inputs at the fan coil. The 24V interface may be connected to a low Tap Speed, based on the installation instructions of the indoor unit.

Table 17 — Compatibility with FMA4 Fan Coils

Indoor	Volt-Ph@60Hz	Kit Number	Nominal System Size MBTUH	Indoor Model Number	Outdoor Model Number	Recommended Maximum Indoor Fan Speed Tap Number
FMA4 Vertical Fan Coil	208/230-1	KSAIC0301230	12	FMA4X1800AL	38MAQB12R--3	Tap 1
			18	FMA4X1800AL	38MAQB18R--3	Tap 2
			24	FMA4X2400AL	38MAQB24R--3	Tap 5
			30	FMA4X3000AL	38MAQB30R--3	Tap 2
			36	FMA4X3000AL	38MAQB36R--3	Tap 4

Table 18 — Compatibility with FMC4 Cased Horizontal Fan Coils

Indoor	Volt-Ph@60Hz	Kit Number	Nominal System Size MBTUH	Indoor Model Number	Outdoor Model Number	Recommended Maximum Indoor Fan Speed Tap Number
FMC4 Cased Horizontal Fan Coil	208/230-1	KSAIC0301230	12	FMC4Z1800AL1	38MAQB12R--3	Low (Black)
			18	FMC4Z1800AL1	38MAQB18R--3	Medium low (Blue)
			24	FMC4Z2400AL1	38MAQB24R--3	Medium low (Blue)
			30	FMC4Z3000AL1	38MAQB30R--3	Medium high (White)
			36	FMC4Z3600AL1	38MAQB36R--3	Medium high (White)

Table 19 — Compatibility with FMU4 Uncased Horizontal Fan Coils

Indoor	Volt-Ph@60Hz	Kit Number	Nominal System Size MBTUH	Indoor Model Number	Outdoor Model Number	Recommended Maximum Indoor Fan Speed Tap Number
FMU4 Uncased Horizontal Fan Coil	208/230-1	KSAIC0301230	12	FMU4Z1800AL1	38MAQB12R--3	Low (Black)
			18	FMU4Z1800AL1	38MAQB18R--3	Medium low (Blue)
			24	FMU4Z2400AL1	38MAQB24R--3	Medium low (Blue)
			30	FMU4Z3000AL1	38MAQB30R--3	Medium high (White)
			36	FMU4Z3600AL1	38MAQB36R--3	Medium high (White)

Table 20 — Compatibility with FV4 Fan Coils

Indoor	Volt-Ph@60Hz	Kit Number	Nominal System Size MBTUH	Indoor Model Number	Outdoor Model Number	Recommended Fan Speed Wiring and Configuration
FV4 Fan Coil	208/230-1	KSAIC0301230	12	FV4CNF002L00	38MAQB12R--3	Connect G1 on the 24V interface to G on the fan coil. Under the configuration taps for AC/HP CFM ADJUST, the recommendation is to select NOM . Refer to Page 10 and Appendix 5 for setup.
			18	FV4CNF002L00	38MAQB18R--3	
			24	FV4CNF002L00	38MAQB24R--3	
			30	FV4CN(B,F)003L	38MAQB30R--3	
			36	FV4CN(B,F)003L	38MAQB36R--3	

APPENDIX 2 - PIPING ADAPTER BUSHINGS/REDUCERS

Model	Size	Bushings/Reducers Required (Field Supplied)
FMA FMC	12-18	3/4" - 1/2" Suction only
		3/8" - 1/4" Liquid
FMA FMC	24-36	3/4" - 5/8" Suction only
		3/8" - 1/4" Liquid
FMU FV4	12-18	3/8" - 1/4" Liquid and 3/4" - 1/2" Suction
	24-36	3/4" - 5/8" Suction only

A piping adapter kit 331831-701 (sold through RDC) is necessary when removing the factory supplied TXV on the indoor unit.

APPENDIX 3 - FV4C TRANSFORMER

This transformer is factory wired for 230V AC operation. For 208V AC applications, disconnect the black wire from the 230-v terminal on the transformer primary side and connect it to the 208V terminal (See Fig. 22).

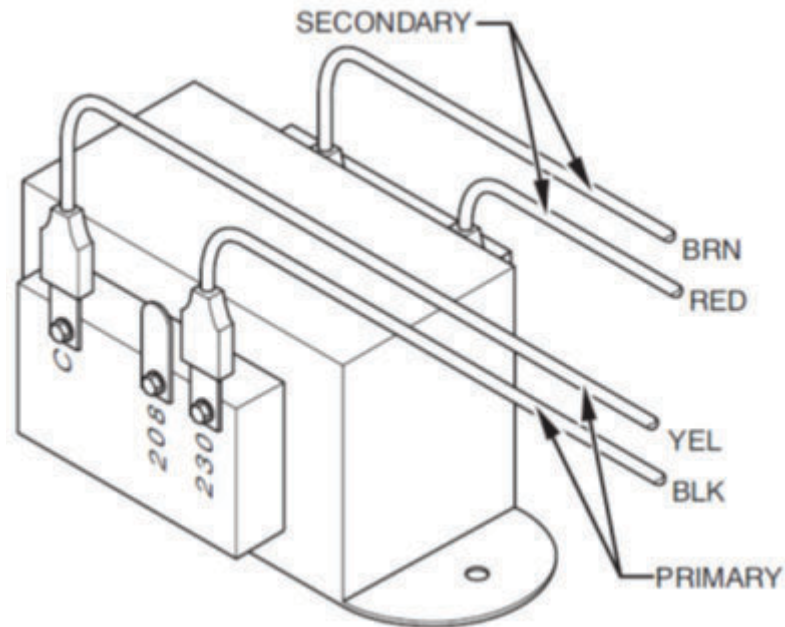

Fig. 22 —Transformer Connections on FV4C Fan Coils

APPENDIX 4 - ADDITIONAL REFRIGERANT CHARGE FOR CONVENTIONAL FAN COILS

When matching the FMA4 and FMC/FMU indoor units, the size 12 units require 12.4 oz. (350 g) more refrigerant due to the size of the indoor coil.

No refrigerant addition is necessary for the FV4 (any size).

All the outdoor units are shipped from the factory pre-charged for 25ft of piping length. See installation instructions of the outdoor unit for additional charge requirements on longer piping lengths.

APPENDIX 5 - FV4C AIRFLOW DELIVERY

Table 21 — FV4C Fan Coil Airflow Delivery (CFM) in Heat Pump Only Heating Mode

OPERATING MODE					
UNIT SIZE	OUTDOOR UNIT CAPACITY	SINGLE SPEED APPLICATION	FAN ONLY		
		HEAT PUMP EFFICIENCY	LO	MED	HIGH
002	012	525	350	380	470
	018	525	350	380	470
	024	700	350	505	630
003	030	875	415	630	785
	036	1050	470	755	945

NOTES:

1. The above airflows result with the AC, HP CFM ADJUST select jumper set on NOM.
2. Air flow can be adjusted +15% or -10% by selecting HI or LO respectively for all modes except fan only.
3. Dry coil at 230 volts and with 10KW heater and filter installed.
4. Airflows shown are at standard air conditions.