

Duct sensor CO₂ / Temperature

Active sensor (0...10 V) for measuring CO₂, with integrated temperature sensor. Dual channel CO₂ technology with range 0...5000ppm. NEMA 4X / IP65 rated enclosure.



5-year warranty

Type Overview

Type	Output signal active CO ₂	Output signal active temperature
22DTC-5105	0...5 V, 0...10 V	0...5 V, 0...10 V

Technical data

Electrical Data	Nominal voltage	AC/DC 24 V
	Nominal voltage range	AC 19...29 V / DC 15...35 V
	Power consumption AC	4.3 VA
	Power consumption DC	2.3 W
	Electrical connection	Pluggable spring loaded terminal block max. 2.5 mm ²
	Cable entry	Cable gland with strain relief Ø6...8 mm (1/2" NPT conduit adapter included)
Functional Data	Sensor Technology	CO ₂ : NDIR (non dispersive infrared) dual channel
	Application	air
	Voltage output	2x 0...5 V, 0...10 V, min. load 10 kΩ
	Output signal active note	output 0...5/10 V with jumper adjustable
Measuring Data	Measured values	CO ₂ Temperature
	Measuring range CO ₂	0...5000 ppm
	Measuring range temperature	40...140°F [4...60°C]
	Accuracy CO ₂	±(50 ppm + 3% of measured value)
	Accuracy temperature active	±0.3°C @ 25°C [±0.54°F @ 77°F]
	Long-term stability	±50 ppm p.a. ±0.07°F p.a. @ 70°F [±0.04°C p.a. @ 21°C] [±39.2°F p.a. @ 69.8°F]
	Time constant τ (63%) in air duct	CO ₂ : typical 33 s @ 1 m/s Temperature: typical 125 s @ 3 m/s
Materials	Cable gland	PA6, black
	Housing	Cover: PC, orange Bottom: PC, orange Seal: NBR70, black UV resistant
	Probe material	PA6, black
Safety Data	Ambient humidity	Max. 95% RH, non-condensing
	Fluid humidity	Max. 95% RH, non-condensing
	Ambient temperature	30...120°F [0...50°C]

Safety Data	Fluid temperature	30...120°F [0...50°C]
	Operating condition air flow	min. 1 ft/s [0.3 m/s] max. 40 ft/s [12 m/s]
	Protection class IEC/EN	III, Safety Extra-Low Voltage (SELV)
	Power source UL	Class 2 Supply
	EU Conformity	CE Marking
	Certification IEC/EN	IEC/EN 60730-1
	Certification UL	cULus acc. to UL60730-1A/-2-9, CAN/CSA E60730-1/-2-9
	Degree of protection IEC/EN	IP65
	Degree of protection NEMA/UL	NEMA 4X
	Enclosure	UL Enclosure Type 4X
	Quality Standard	ISO 9001
	Mode of operation	Type 1
	Pollution degree	3
	Rated impulse voltage supply	0.8 kV
	Construction	Independently mounted control

Safety Notes

This device has been designed for use in stationary heating, ventilation and air-conditioning systems and must not be used outside the specified field of application. Unauthorized modifications are prohibited. The product must not be used in relation with any equipment that in case of a failure may threaten humans, animals or assets.

Ensure all power is disconnected before installing. Do not connect to live/operating equipment.

Only authorized specialists may carry out installation. All applicable legal or institutional installation regulations must be complied during installation.

The device contains electrical and electronic components and must not be disposed of as household refuse. All locally valid regulations and requirements must be observed.

Remarks

General Remarks Concerning Sensors Sensing devices with a transducer should always be operated in the middle of the measuring range to avoid deviations at the measuring end points. The ambient temperature of transducer electronics should be kept constant. The transducers must be operated at a constant supply voltage (± 0.2 V). When switching the supply voltage on/off, onsite power surges must be avoided.

Build-up of self-heating by electrical dissipative power Temperature sensors with electronic components always have a dissipative power which affects the temperature measurement of the ambient air. The dissipation in active temperature sensors shows a linear increase with rising operating voltage. The dissipative power should be taken into account when measuring temperature.

In case of a fixed operating voltage (± 0.2 V) this is normally done by adding or reducing a constant offset value. As Belimo transducers work with a variable operating voltage, only one operating voltage can be taken into consideration, for reasons of production engineering. Transducers 0...10 V / 4...20 mA have a standard setting at an operating voltage of DC 24 V. That means, that at this voltage, the expected measuring error of the output signal will be the least. For other operating voltages, the offset error will be increased by a changing power loss of the sensor electronics.

If a readjustment directly at the active sensor should be necessary during later operation, this can be done with the following adjustment methods.

- For sensors with NFC or dongle by the corresponding Belimo app
- For sensors with a trimming potentiometer on the sensor board
- For bus sensors via bus interface with a corresponding software variable

Information self-calibration feature CO₂

All CO₂ sensors are subject to drift caused by the aging process of the components, resulting in regular re-calibration or replacement of units. However, the dual channel technology integrates automatic self-calibration technology vs. common used ABC-Logic sensors. Dual channel self-calibration technology is ideally suited for applications operating 24/7 hours such as those in hospitals or other commercial applications. Manual calibration is not required.

Scope of delivery

Scope of delivery	Description	Type
	Mounting flange for duct sensor 19.5 mm, up to max. 120°C [248°F], Plastic	A-22D-A34
	1/2" NPT conduit adapter	

Accessories

Optional accessories	Description	Type
	Replacement filter, wire mesh, Stainless steel	A-22D-A06
	Mounting plate L housing	A-22D-A10
Service tools	Description	Type
	Belimo Duct Sensor Assistant App	Belimo Duct Sensor Assistant App
	Bluetooth dongle for Belimo Duct Sensor Assistant App	A-22G-A05
	* Bluetooth dongle A-22G-A05	
	Certified and available in North America, European Union, EFTA States and UK.	

Service tools connection

This sensor can be operated and parametrized using the Belimo Assistant App.

When using the Belimo Duct Sensor Assistant App, the Bluetooth dongle is required to enable communication between the app and the Belimo sensor.

For the standard operation and parametrization of the sensor the Bluetooth dongle and the Belimo Duct Sensor Assistant App are not needed. The sensor will arrive pre-configured with the factory default settings shown above.

Requirement:

- Bluetooth dongle (Belimo Part No: A-22G-A05)
- Bluetooth-capable smartphone
- Belimo Duct Sensor Assistant App (Google Play & Apple App Store)

Procedure:

- Plug the Bluetooth dongle into the sensor via the Micro-USB connector or by means of the interface PCB
- Connect Bluetooth-capable smartphone with Bluetooth dongle
- Select parametrization in the Belimo Assistant App

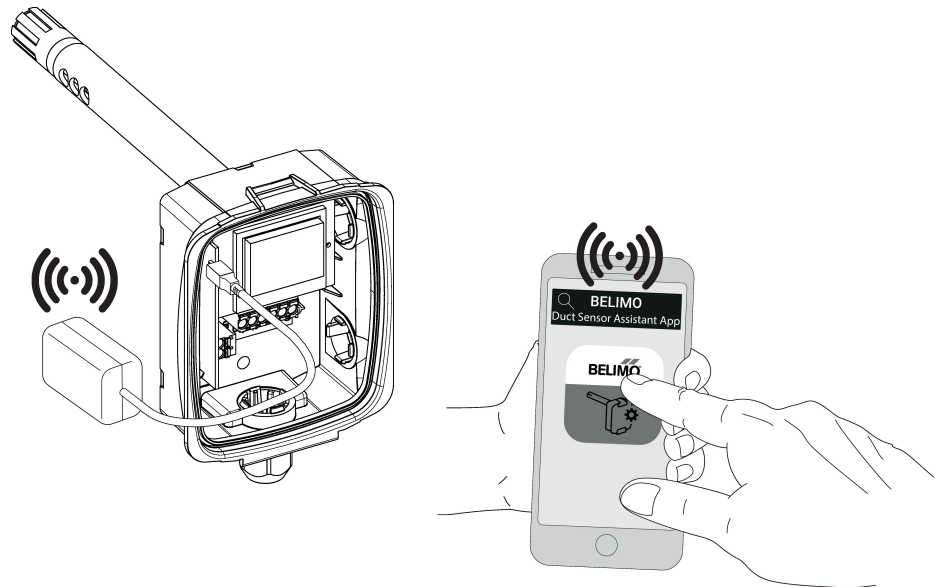

Wiring Diagram

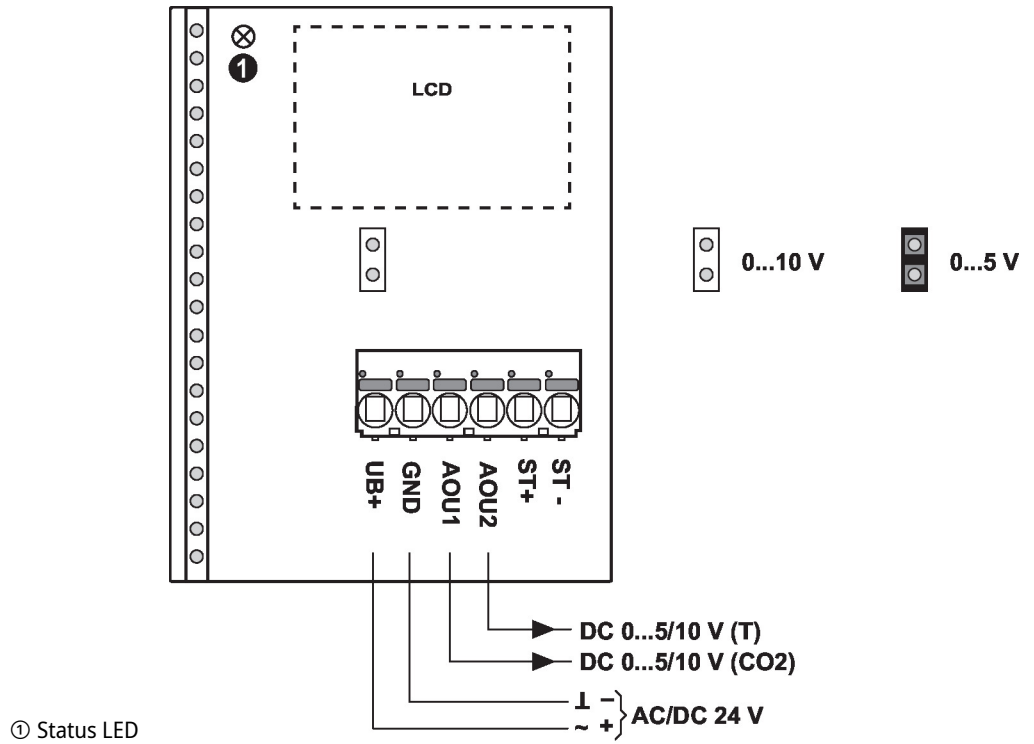

Dimensions

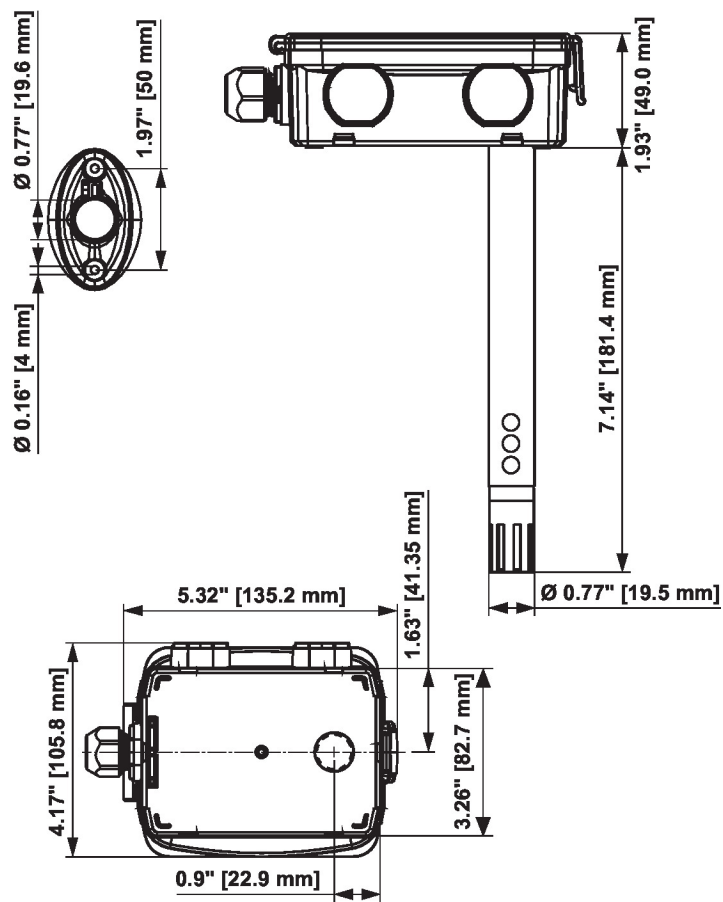

Type	Probe length	Weight
22DTC-5105	7" [180 mm]	0.60 lb [0.27 kg]