

**25VNA4  
INFINITY®  
VARIABLE SPEED HEAT PUMP  
WITH GREENSPEED™ INTELLIGENCE  
2 TO 5 NOMINAL TONS**



Turn to the experts

## PRODUCT DATA



### Industry leading Features / Benefits

#### Energy Efficiency

- Up to 24 SEER, 15 EER, 13 HSPF
- Microtube Technology™ refrigeration system
- Indoor air quality accessories available

#### Sound

- Sound level as low as 51 dBA in low speed .

#### Comfort

- Variable speed compressor with capacity range from 25-100%
- Air cooled Inverter variable speed drive
  - System requires Infinity Control with Greenspeed capability
  - Energy Tracking capability with the Infinity Control Wall Control w/latest software version  
(Energy Tracking has the ability to monitor and estimate the energy consumption of your Infinity system.)

#### Reliability

- Non-ozone depleting Puron® refrigerant
- Front-seating service valves
- Greenspeed Intelligence actively monitors critical system parameters
- High pressure switch
- Discharge pressure transducer
- Electronic expansion valve (EXV) for heating, TXV for cooling
- Filter drier (field installed)
- Internal crankcase heater standard

#### Flexibility and installation:

- 2 control wires to outdoor unit
- Minimum and maximum airflow adjustments
- Compressor heating capacity control
- Hybrid Heat™ Dual Fuel capable

#### Durability

WeatherArmor Ultra™ protection package:

- Solid, Durable sheet metal construction
- Steel louver coil guard
- Baked-on, complete outer coverage, powder paint

#### Applications

- Long-line - up to 250 feet (76.2 m) total equivalent length, up to 200 feet (60.96 m) condenser above evaporator, or up to 80 ft. (24.38 m) evaporator above condenser (See Longline Guide for more information.)

Carrier's 25VNA4 with Greenspeed™ Intelligence is a breakthrough product providing up to 13 HSPF heating efficiency and up to 24 SEER cooling efficiency. The variable speed capacity control results in strong heating capacity as the outdoor temperature drops resulting in less reliance on auxiliary heat. Lower speed operation, when needed in cooling, for enhanced comfort and dehumidification.

This product has been designed and manufactured to meet Energy Star® criteria for energy efficiency when matched with appropriate coil components. Refer to the combination ratings in this Product Data for system combinations that meet Energy Star guidelines.

**NOTE:** Ratings contained in this document are subject to change at any time. Always refer to the AHRI directory ([www.ahridirectory.org](http://www.ahridirectory.org)) for the most up-to-date ratings information.

### Model Number Nomenclature

1	2	3	4	5	6	7	8	9	10	11	12	13
N	N	A	A	A/N	N	N	N	A/N	A/N	A/N	N	N
2	5	V	N	A	4	3	6	A	0	0	3	0
Product Series	Product Family	Tier	Major Series	SEER	Cooling Capacity	Variations	Open	Open	Voltage	Minor Series		
25 = HP	V = VS HP	N= Infinity Series	A = Puron		1,000 Btuh (nominal)	A = Standard	0=Not Defined	0=Not Defined	3=208/230-1	0, 1, 2...		



Use of the AHRI Certified TM Mark indicates a manufacturer's participation in the program. For verification of certification for individual products, go to [www.ahridirectory.org](http://www.ahridirectory.org).



Quality ISO 9001  
SAI GLOBAL



This product has been designed and manufactured to meet Energy Star criteria for energy efficiency when matched with appropriate coil components. However, proper refrigerant charge and proper air flow are critical to achieve rated capacity and efficiency. Installation of this product should follow all manufacturing subsequent charging and air flow instructions. Failure to conform proper charge and air flow may reduce energy efficiency and shorten equipment life.



### Standard Features

FEATURES	Unit Size			
	24	36	48	60
Puron Refrigerant	X	X	X	X
Variable Speed Rotary Compressor	X	X	X	
Variable Speed Scroll Compressor				X
Air-Cooling Inverter Drive	X	X	X	X
Louvered Coil Guard	X	X	X	X
Field-Installed Filter Drier	X	X	X	X
Front-Seating Service Valves	X	X	X	X
Internal Pressure and Temperature Protection	X	X	X	X
Suction Pressure Transducer	X	X	X	X
High Pressure Switch	X	X	X	X
Crankcase Heater	X	X	X	X
Utility Interface Connections	X	X	X	X
Bluetooth® Module	X	X	X	X
Enhanced Diagnostics	X	X	X	X
Energy Tracking Capability	X	X	X	X
Dual Sound Blanket	X	X	X	X
Outdoor Air Temperature Sensor	X	X	X	X
Long Line Capability	X	X	X	X

X = Standard

## Refrigerant Piping Length Limitations

### Maximum Line Lengths:

The maximum allowable total equivalent length for heat pumps varies depending on the vertical separation. See the tables below for allowable lengths depending on whether the outdoor unit is on the same level, above or below the outdoor unit.

#### Maximum Line Lengths for Heat Pump Applications

	MAXIMUM ACTUAL LENGTH* ft (m)	MAXIMUM EQUIVALENT LENGTH† ft (m)	MAXIMUM VERTICAL SEPARATION ft (m)
Units on equal level	200 (61)	250 (76.2)	N/A
Outdoor unit ABOVE indoor unit	200 (61)	250 (76.2)	200 (61)
Outdoor unit BELOW indoor unit	See Table 'Maximum Total Equivalent Length: Outdoor Unit BELOW Indoor Unit'		

\*.Maximum actual length not to exceed 200 ft (61 m)

†.Total equivalent length accounts for losses due to elbows or fitting. See the Long Line Guideline for details.

#### Maximum Total Equivalent Length\* - Outdoor Unit BELOW Indoor Unit

Size	Liquid Line Diameter w/ TXV	HP with Puron® Refrigerant - Maximum Total Equivalent Length* Vertical Separation ft (m) Outdoor unit BELOW indoor unit;						
		0-20 (0 - 6.1)	21-30 (6.4 - 9.1)	31-40 (9.4 - 12.2)	41-50 (12.5 - 15.2)	51-60 (15.5 - 18.3)	61-70 (18.6 - 21.3)	71-80 (21.6 - 24.4)
024	3/8	250*	250*	250*	250*	250*	250*	250*
036	3/8	250*	250*	250*	250*	250*	250*	250*
048	3/8	250*	250*	250*	250*	230	160	--
060	3/8	250*	225*	190	150	110	--	--

\*.Total equivalent length accounts for losses due to elbows or fitting. See the Long Line Guideline for details.

-- = Outside acceptable range.

### Long Line Applications

An application is considered Long Line when the refrigerant level in the system requires the use of accessories to maintain acceptable refrigerant management for systems reliability. Defining a system as long line depends on the liquid line diameter, actual length of the tubing, and vertical separation between the indoor and outdoor units.

For Heat Pump systems, the chart below shows when an application is considered Long Line. Beyond these lengths, long line accessories are required:

#### HP with Puron® Refrigerant Long Line Description ft (m) Beyond these lengths, long line accessories are required

Liquid Line Size	Units On Same Level	Outdoor Below Indoor	Outdoor Above Indoor
3/8	80 (24.4)	20 (6.1) vertical or 80 (24.4) total	80 (24.4)

NOTE: See Long Line Guideline for details

### COOLING CAPACITY LOSS TABLE

Nominal Size (Btuh)	Line OD (in)	Cooling Capacity Loss (%) Total Equivalent Length (ft)										
		25	50	75	80	100	125	150	175	200	225	250
24000	5/8	0.5	1.0	2.0	2.0	2.5	3.0	3.5	4.5	5.0	5.5	6.0
	<b>3/4</b>	0.0	0.5	0.5	0.5	1.0	1.0	1.5	1.5	2.0	2.0	2.5
36000	5/8	1.0	2.5	3.5	4.0	5.0	6.5	7.5	9.0	10.5	11.5	13.0
	3/4	0.5	1.0	1.5	1.5	2.0	2.5	3.0	3.0	3.5	4.0	4.5
	<b>7/8</b>	0.0	0.5	0.5	0.5	1.0	1.0	1.5	1.5	2.0	2.0	2.5
48000	3/4	0.5	1.5	2.5	2.5	3.0	4.0	5.0	5.5	6.5	7.5	8.0
	7/8	0.5	0.5	1.0	1.0	1.5	2.0	2.5	3.0	3.0	3.5	4.0
	<b>1 1/8</b>	0.0	0.0	0.0	0.5	0.5	0.5	0.5	0.5	1.0	1.0	1.0
60000	3/4	1.0	2.5	3.5	4.0	5.0	6.0	7.5	8.5	10.0	11.0	12.5
	7/8	0.5	1.0	1.5	2.0	2.5	3.0	3.5	4.0	5.0	5.5	6.0
	<b>1 1/8</b>	0.0	0.0	0.5	0.5	0.5	0.5	1.0	1.0	1.0	1.5	1.5

Rating size in BOLD

= TE Length greater than 80 ft requires long line accessory liquid line solenoid.

## Equipment sizing Guidelines

If primary load is cooling, size the same as any other air conditioning system. If primary load is heating, use the chart below for maximum size for heating.

### Maximum Recommended Equipment Size - Heating

COOLING LOAD (tons)	MAXIMUM RECOMMENDED EQUIPMENT SIZE FOR HEATING*
2	36
2.5	36
3	48
3.5	60
4	60
5	60

\*. Make sure duct work is capable of delivering required airflow . Make sure combination rating exists for desired combination

## MIN/MAX Airflow tables

The indoor airflow delivered by this system varies significantly based on outdoor temperature, indoor unit combination, and system demand. The airflows on these tables are for duct design considerations.

Duct systems capable of these ranges will ensure the system will deliver full capacity at all outdoor temperatures.

Minimum and maximum airflows can be adjusted from these numbers in the Infinity Control Heat Pump Setup screen.

Size	Cooling - Comfort Mode		Cooling - Efficiency Mode	
	Max Capacity	Min Capacity	Max Capacity	Min Capacity
24	700	300	900	500
36	750	300	1100	300
48	1200	500	1600	600
60	1400	500	2000	750

Size	Heating - Comfort Mode		Heating - Efficiency Mode	
	Max Capacity	Min Capacity	Max Capacity	Min Capacity
24	850	300	1000	650
36	1500	300	1500	650
48	1550	500	1600	600
60	2000	500	2000	850

## Physical Data

UNIT SIZE SERIES	24-30	36-30	48-30	60-30
<b>COMPRESSOR TYPE</b>	Variable Speed rotary			Variable Speed Scroll
<b>REFRIGERANT</b>	Puron® (R-410A)			
Control	TXV (Puron® Hard Shutoff)			
Charge lb (kg)	8.9 (4.05)	14.1 (6.4)	14.15 (6.42)	16.25 (7.37)
Outdoor Htg Exp. Device	EXV	EXV	EXV	EXV
<b>COND FAN</b>	Forward Swept Propeller Type, Direct Drive			
Air Discharge	Vertical			
Air Qty (CFM)	3100	4100	4700	4700
Motor HP	1/3	1/3	1/3	1/3
Motor RPM	200-800	200-800	200-800	200-800
<b>COND COIL</b>				
Face Area (Sq ft)	30.25	33	33	33
Fins per In.	20	20	20	20
Rows	2	2	2	2
Circuits	5	8	9	9
<b>VALVE CONNECT. (In. ID)</b>				
Vapor	3/4	7/8	7/8	7/8
Liquid	3/8			
<b>REFRIGERANT TUBES (In. OD)</b>				
Rated Vapor*	3/4	7/8	1-1/8	1-1/8
Max Liquid Line	3/8			

\*. Units are rated with 25 ft (7.6 m) of lineset length. See Vapor Line Sizing and Cooling Capacity Loss table when using other sizes and lengths of lineset.

Note: See unit Installation Instruction for proper installation.

## Electrical Data

UNIT SIZE-VOLTAGE, SERIES	V/PH	OPER VOLTS*		COMPR		FAN	MCA	MAX FUSE† or CKT BRK AMPS
		MAX	MIN	LRA	RLA	FLA		
24-30	208-230-1	253	197	N/A	12.4	0.88	16.4	25
36-30				N/A	13.7	0.88	18.0	30
48-30				N/A	21.2	0.88	27.4	40
60-30				N/A	26.6	0.88	34.2	50

\*. Permissible limits of the voltage range at which the unit will operate satisfactorily

†. Time-Delay fuse.

FLA - Full Load Amps

LRA - Locked Rotor Amps

MCA - Minimum Circuit Amps

RLA - Rated Load Amps

NOTE: Control circuit is 24-V on all units and requires external power source. Copper wire must be used from service disconnect to unit.

All motors/compressors contain internal overload protection.

Complies with 2010 requirements of ASHRAE Standards 90.1

## Charging Subcooling (TXV-Type Expansion Device)

UNIT SIZE-VOLTAGE, SERIES	REQUIRED SUBCOOLING °F (°C) - See UI
24-30	Subcooling recommendation displayed on UI in Charging Mode must be followed
36-30	
48-30	
60-30	

## Accessories

KIT NUMBER	KIT NAME	24-30	36-30	48-30	60-30
KSASF0201AAA	SUPPORT FEET	X	X	X	X
KHASS0606MPK	SNOW STAND	X	X	X	X
KSATX0301PUR	TXV KIT	X	X		
KSBTX0301PUR	TXV KIT	X	X		
KSATX0401PUR	TXV KIT			X	X
KSBTX0401PUR	TXV KIT			X	X

x = Accessory

## ACCESSORY USAGE GUIDELINE

ACCESSORY	REQUIRED FOR LOW-AMBIENT COOLING APPLICATIONS (Below 55°F/12.8_C)	REQUIRED FOR LONG LINE APPLICATIONS* (Over 80 ft/24.38 m)	REQUIRED FOR SEA COAST APPLICATIONS (Within 2 miles/3.22 km)
Crankcase Heater	Standard	Standard	Standard
Evaporator Freeze Protection	Standard with Infinity Control	No	No
Liquid-Line Solenoid Valve	No	Yes	No
Low-Ambient Control	Standard with Infinity Control	No	No
Puron Refrigerant Balance Port Hard-ShutOff TXV	Yes†	Yes†	Yes†
Support Feet	Recommended	No	Recommended
Winter Start Control	Standard with Infinity Control	No	No

\*. For tubing set lengths between 80 and 200 ft. (24.38 and 60.96 m) horizontal or 20 ft. (6.10 m) vertical differential (total equivalent length), refer to the Long Line Guideline—Air Conditioners and Heat Pumps using Puron® Refrigerant.

†. Required on all indoor units. Standard on all new Greenspeed compatible fan coils and furnace coils.

## Accessory Description and Usage (Listed Alphabetically)

### 1. Compressor Start Assist

The inverter drive gently starts the variable speed compressor at all times. No other start device is compatible with this unit.

### 2. Crankcase Heater

This unit has a compressor crankcase heater that will be energized to prevent the compressor from being the coldest part of the system thus enhancing reliability. the indoor unit and UI do not need to be installed for the crankcase heater to operate properly..

### 3. Liquid-Line Solenoid Valve (LLS)

An electrically operated shutoff valve which stops and starts refrigerant liquid flow in response to compressor operation. It is to be installed at the outdoor unit to control refrigerant off cycle migration in the OFF mode.

Usage Guideline:

An LLS is required in all long line applications to control refrigerant off cycle migration in the OFF mode. See Long Line Guideline.

Suggested for all commercial applications.

### 4. Snow Stand

Coated wire rack which supports unit 18 in. (457.2 mm) above mounting pad to allow for drainage from unit base.

Usage Guideline:

Suggested in the following applications:

- Unit installations in heavy snowfall areas.
- Unit installations in snow drift locations.
- Unit installations in areas of prolonged subfreezing temperatures.
- All commercial installations.

### 5. Thermostatic Expansion Valve (TXV) Bi-Flow

A modulating flow-control valve which meters refrigerant liquid flow rate into the evaporator in response to the superheat of the refrigerant gas leaving the evaporator.

Usage Guideline:

Accessory required to meet AHRI rating and system reliability, where indoor not equipped.

**Sound Power Level (dBA)**

Unit Size	Typical Octave Band Spectrum	Min Speed Cooling	Max Speed Cooling	Min Speed Heating	Max Speed Heating
<b>24</b>	Speed	900	3480	900	6000
	125	53.5	61.3	53.2	69.5
	250	53.0	55.2	54.7	70.3
	500	47.4	53.2	49.4	68.1
	1000	44.5	53.6	43.6	67.9
	2000	37.1	49.8	39.1	65.6
	4000	33.9	50.5	38.5	66.7
	8000	42.3	49.6	41.8	63.3
	Sound Rating (dBA)	51	59	52	74
<b>36</b>	Speed	900	3960	900	6060
	125	57.4	62.6	54.9	70.8
	250	62.2	62.5	58.8	72.8
	500	49.9	60.5	45.9	65.6
	1000	47.5	59.5	49.0	63.4
	2000	43.5	54.7	44.3	65.0
	4000	39.1	51.3	38.7	58.7
	8000	46.7	48.6	44.3	55.6
	Sound Rating (dBA)	56	64	54	71
<b>48</b>	Speed	900	3060	900	4700
	125	55.0	67.4	55.6	75.4
	250	59.7	66.5	60.4	64.9
	500	51.9	64.4	52.5	64.1
	1000	47.6	59.7	49.9	60.3
	2000	44.2	57.2	42.6	68.8
	4000	45.9	55.3	36.5	56.5
	8000	43.2	55.4	43.6	54.6
	Sound Rating (dBA)	56	66	56	72
<b>60</b>	Speed	960.0	3420.0	900.0	4500.0
	125	59.6	71.1	55.0	65.8
	250	60.6	71.7	55.4	70.1
	500	57.4	70.5	51.7	65.4
	1000	50.6	66.4	47.5	63.4
	2000	48.3	65.2	45.7	63.7
	4000	41.2	58.3	41.3	62.6
	8000	42.6	55.7	41.5	55.4
	Sound Rating (dBA)	58	72	54	71

NOTE: Tested in compliance with AHRI 270-2008 but not listed with AHRI.

# Dimensions

UNIT	SERIES	ELECTRICAL CHARACTERISTICS				A		B		C		D		E		F		G		H		I		J		K		OPERATING WEIGHT		SHIPPING WEIGHT		SHIPPING LENGTH / WIDTH (Sq.)		SHIPPING HEIGHT	
		Y	N	N	N	INCH	MM	INCH	MM	INCH	MM	INCH	MM	INCH	MM	INCH	MM	INCH	MM	INCH	MM	INCH	MM	INCH	MM	INCH	MM	Lbs	Kgs	Lbs	Kgs	INCH	MM	INCH	MM
25VNA424A0030050	0	Y	N	N	N	35	889.0	43 13/16	1112.6	3/4	19.1	6 9/16	166.1	28 7/16	722.8	9 1/8	231.3	1 1/8	28.2	3 13/16	97.4	15 7/8	403.2	16 3/8	415.9	20 1/2	520.7	276	125.2	298	135.2	37 13/16	960.0	48 5/8	1235.0
25VNA436A0030050	0	Y	N	N	N	35	889.0	47 3/16	1199.0	7/8	22.2	6 9/16	166.1	28 7/16	722.8	9 1/8	231.3	1 1/8	28.2	3 13/16	97.4	16 1/2	419.1	16 1/2	419.1	21	533.4	344	156.0	367	166.5	37 13/16	960.0	52	1321.4
25VNA448A0030050	0	Y	N	N	N	35	889.0	47 3/16	1199.0	7/8	22.2	6 9/16	166.1	28 7/16	722.8	9 1/8	231.3	1 1/8	28.2	3 13/16	97.4	16 1/2	419.1	16 1/2	419.1	21	533.4	373	169.2	396	179.6	37 13/16	960.0	52	1321.4
25VNA460A0030040	0	Y	N	N	N	35	889.0	47 3/16	1199.0	7/8	22.2	6 9/16	166.1	28 7/16	722.8	9 1/8	231.3	1 1/8	28.2	3 13/16	97.4	16 1/2	419.1	16 1/2	419.1	21	533.4	380	172.4	403	182.8	37 13/16	960.0	52	1321.4

208-230-1-60	Y=YES N=NO
208/230-3-60	
460-3-60	
575-3-60	

NOTES:

- CENTER OF GRAVITY 

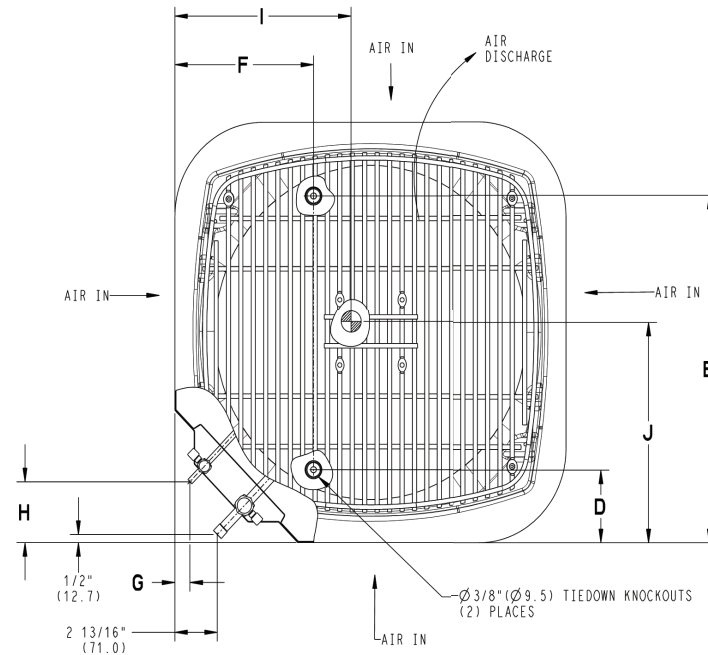
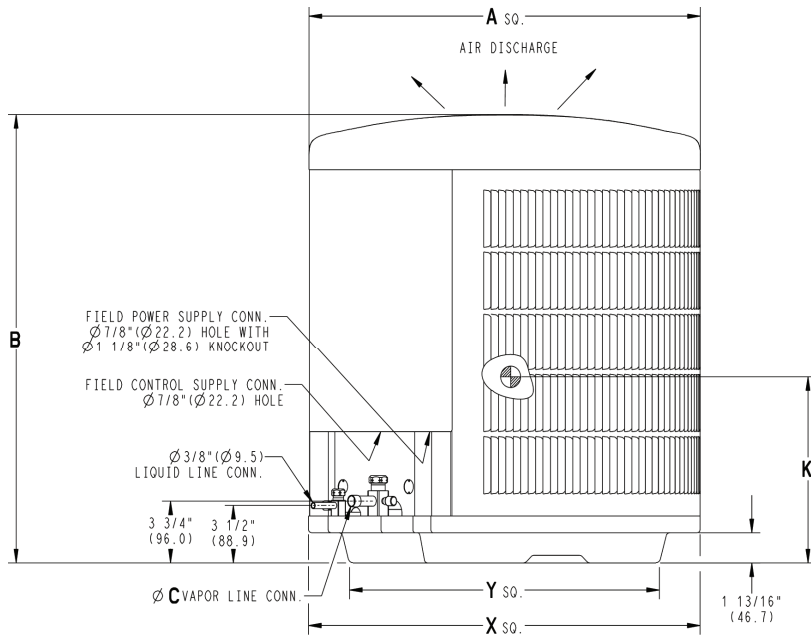

UNIT SIZE	"X" MINIMUM GROUND MOUNTING PAD APPLICATION DIMENSIONS		"Y" MINIMUM ROOF-TOP MOUNTING PAD APPLICATION DIMENSIONS	
	INCH	MM	INCH	MM
-	23 1/8	587.3	17 7/8	454.6
-	25 3/4	654.0	20 7/16	518.5
-	31 3/16	792.5	22 15/16	583.2
24,36,48,60	35	889.0	26 3/4	679.7

NOTE: ALL DIMENSIONS IN INCH (MM)

U.S. ECCN: Not Subject to Regulation (N.S.R.)

### 2 TON BALANCE POINT WORKSHEET COMFORT MINIMUM AND MAXIMUM HEATING CAPACITIES

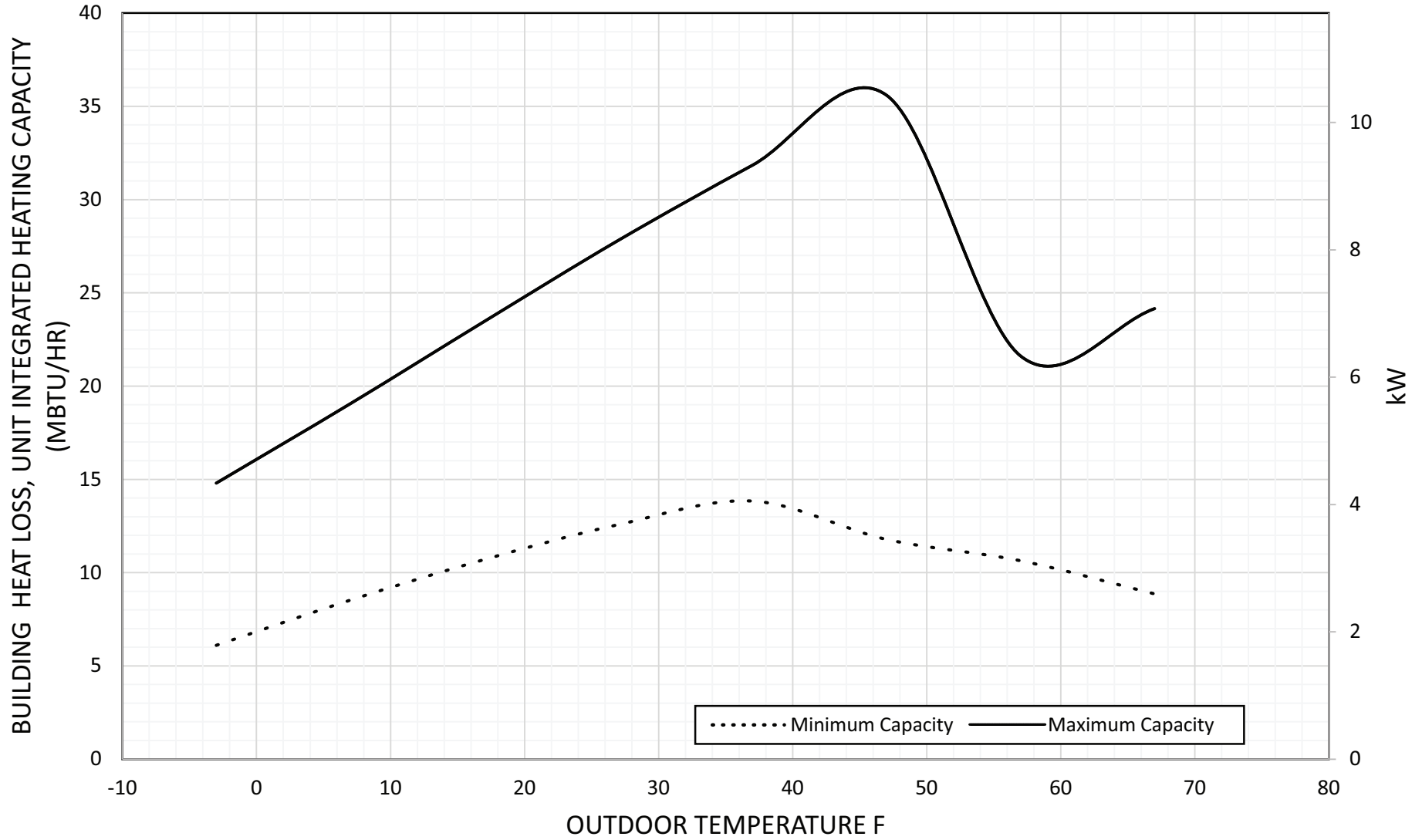

### 3 TON BALANCE POINT WORKSHEET COMFORT MINIMUM AND MAXIMUM HEATING CAPACITIES

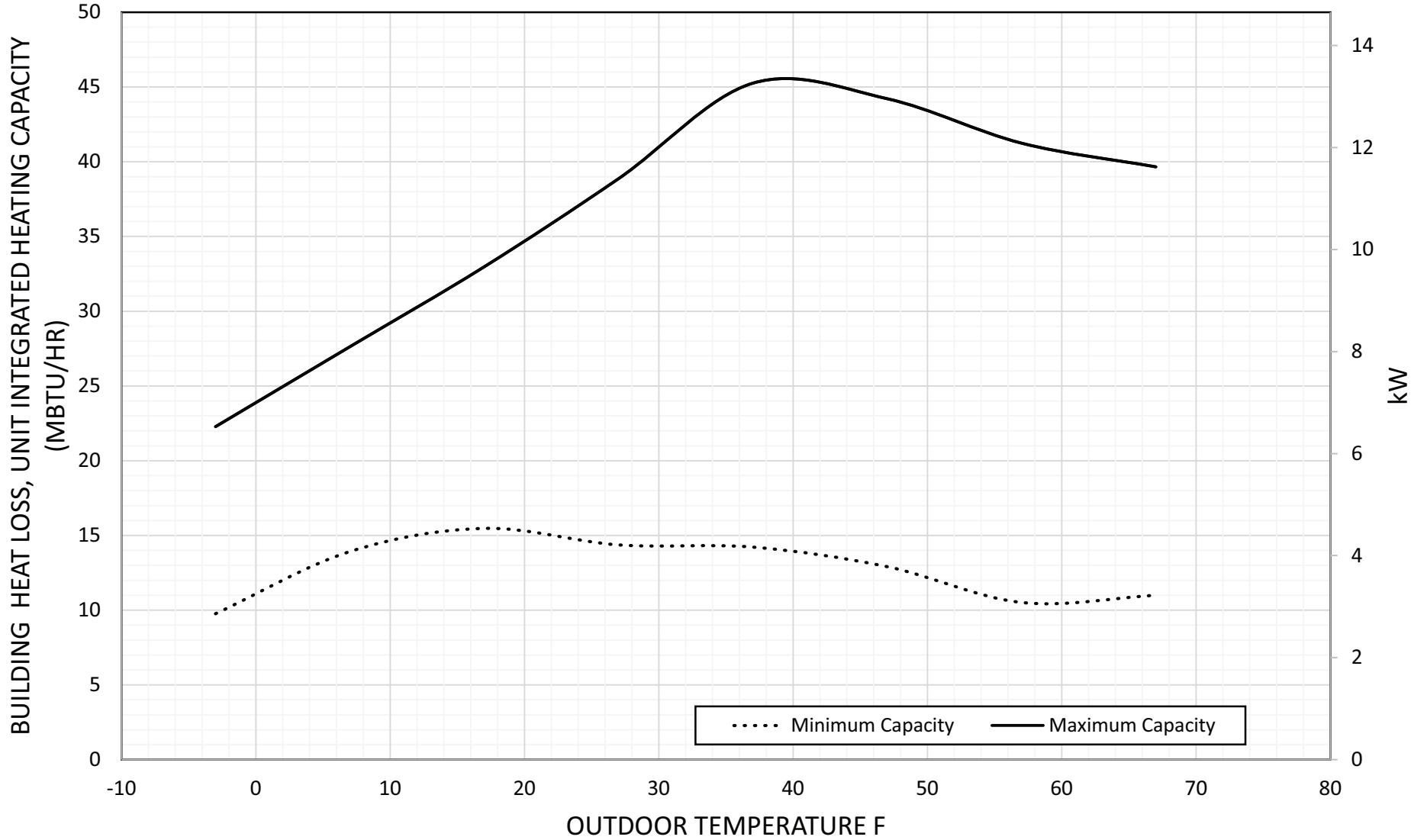

### 4 TON BALANCE POINT WORKSHEET COMFORT MINIMUM AND MAXIMUM HEATING CAPACITIES

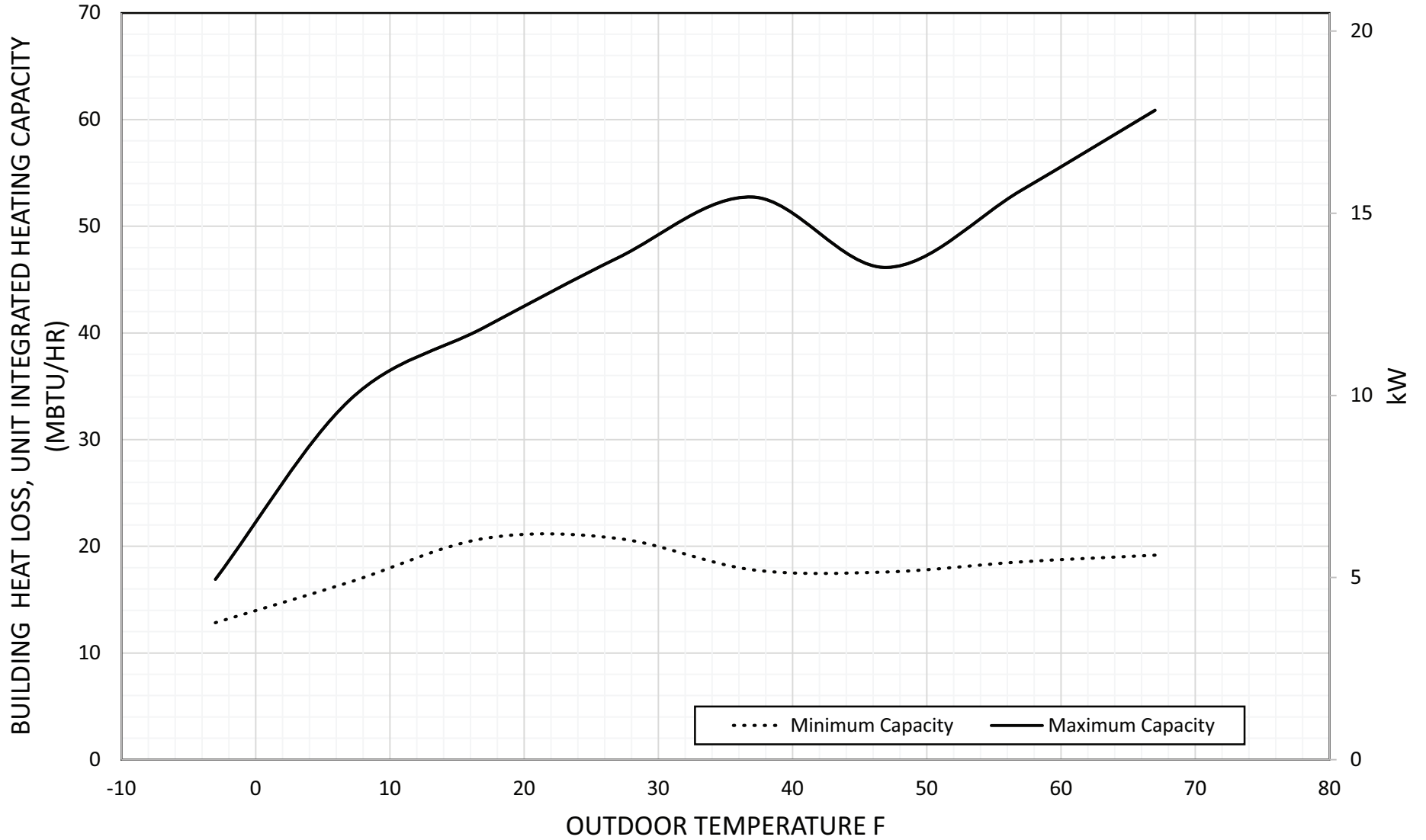

### 5 TON BALANCE POINT WORKSHEET COMFORT MINIMUM AND MAXIMUM HEATING CAPACITIES

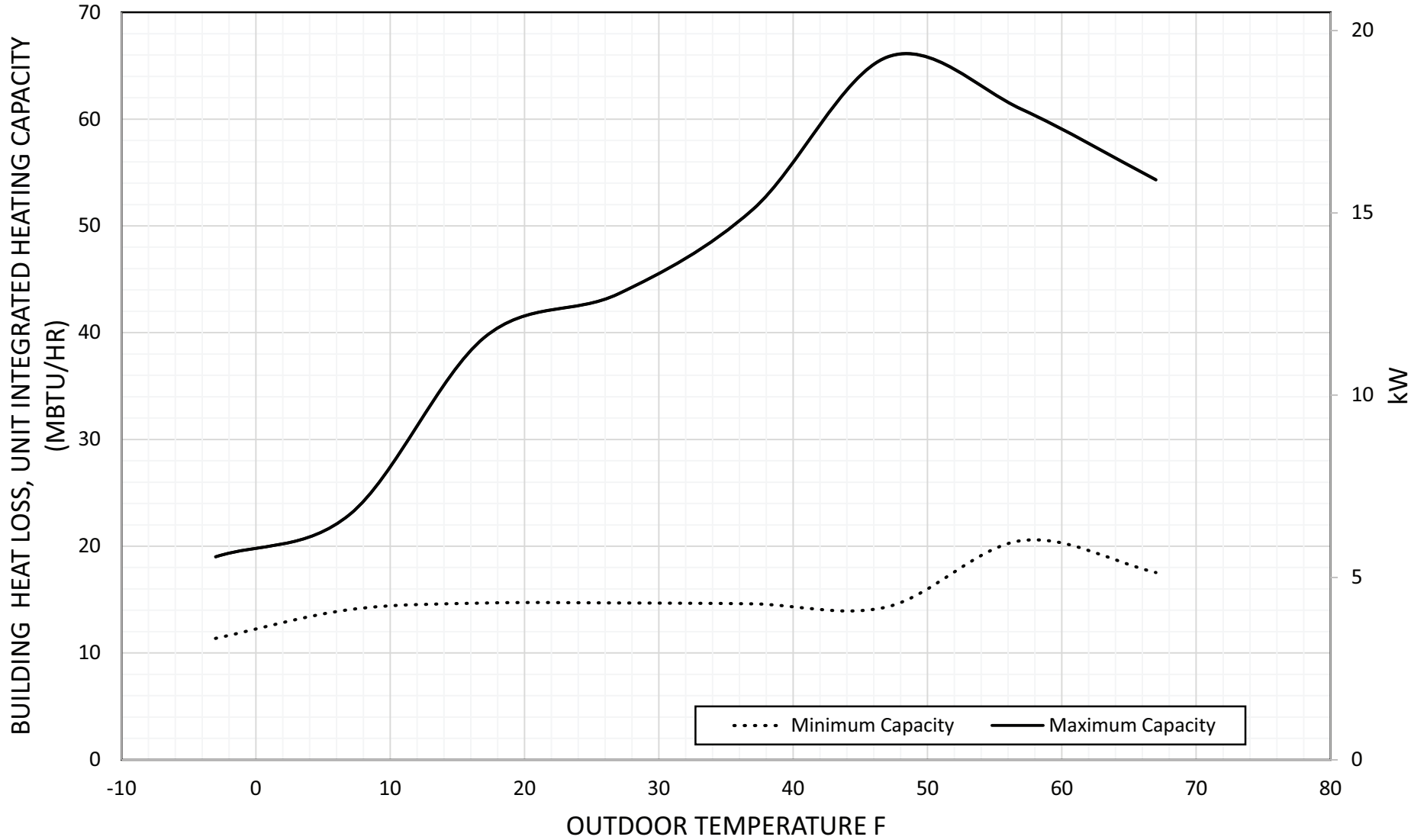

# Clearances

## Clearances (various examples)

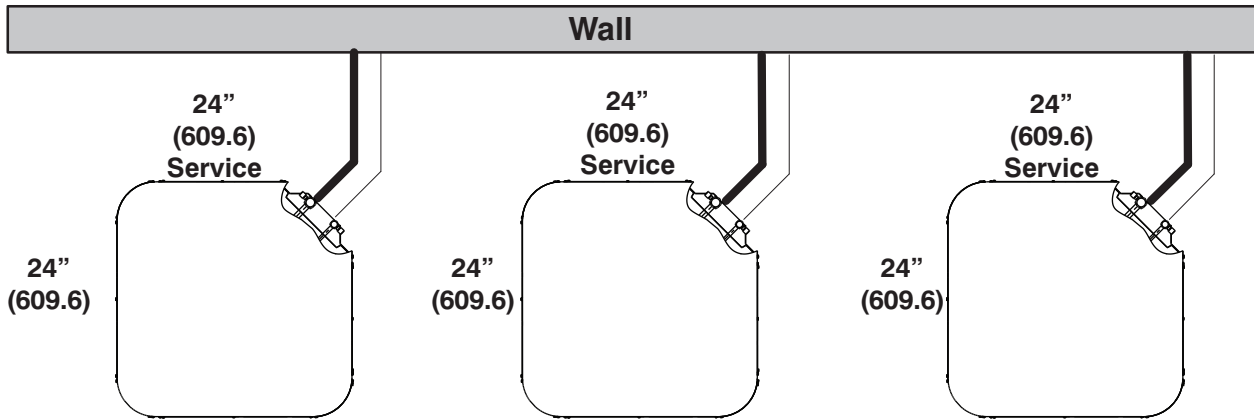
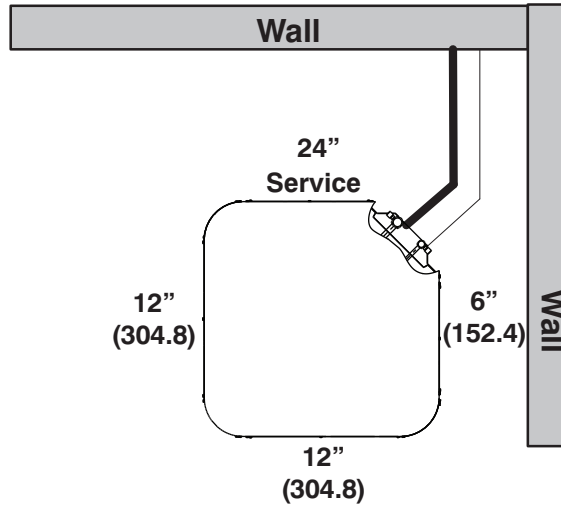
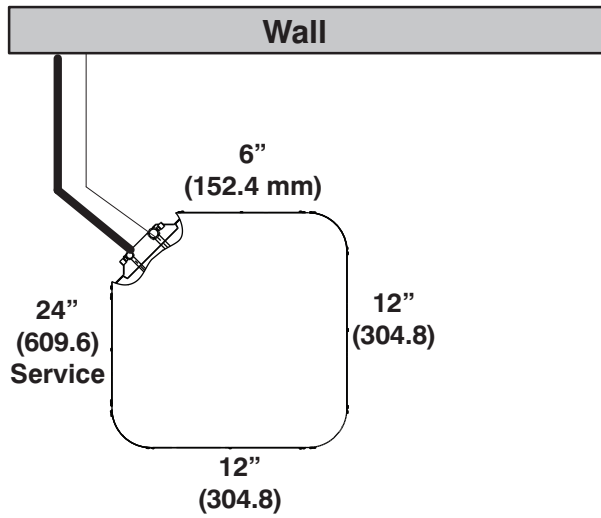

Note: Numbers in ( ) = mm

**IMPORTANT:** When installing multiple units in an alcove, roof well, or partially enclosed area, ensure there is adequate ventilation to prevent re-circulation of discharge air.

## Tested AHRI Combination Ratings\*

**NOTE:** Ratings contained in this document are subject to change at any time.

For AHRI ratings certificates, please refer to the AHRI directory [www.ahridirectory.org](http://www.ahridirectory.org)

Additional ratings and system combinations can be accessed via the Carrier database at: [www.MyCarrierRatings.com](http://www.MyCarrierRatings.com) Equipment performance calculator can be accessed at: <http://rpmob.wrightsoft.com/>

Model Number	Coil Model Number	Clg Cap High	EER	SEER	ID		Heating 47°F Temp		HSPF	Heating 17°F Temp	
					High	Low	Capacity	COP		Capacity	COP
25VNA424A**30	FE4ANF002L+UI	23400	14	22.0	850	500	24,000	3.78	11	24,400	2.62
25VNA436A**30	FE4AN(B,F)005L+UI	34600	13.5	22.5	1100	550	35,000	3.80	11	32,800	2.54
25VNA448A**30	FE4ANB006L+UI	46000	13.5	22.0	1600	600	46,000	3.92	11	42,500	2.60
25VNA460A**30	FE4ANB006L+UI	58500	13	21.0	1625	900	59,000	3.36	11	49,500	2.66

\* Ratings are net values reflecting the effects of circulating fan heat. Supplemental electric heat is not included. Ratings are based on:

**Cooling Standard:** 80°F (27°C) db 67°F (19°C) wb indoor entering air temperature and 95°F (35°C) db air entering outdoor unit.

**High-Temp Heating Standard:** 70°F (21°C) db indoor entering air temperature and 47°F (8°C) db 43°F (6°C) wb air entering outdoor unit.

**Low-Temp Heating Standard:** 70°F (21°C) db indoor entering air temperature and 17°F (-8°C) db 15°F (-9°C) wb air entering outdoor unit.

**COP** — Coefficient of Performance

**EER** — Energy Efficiency Ratio

**HSPF** — Heating Seasonal Performance Factor

**SEER** — Seasonal Energy Efficiency Ratio

**UI** — User Interface

# Detailed Cooling Capacities# - Comfort + Dehumidify Mode

25VNA42424/FE4ANB002 COOLING COMFORT + DEHUMIDIFY MODE CONDENSER ENTERING AIR TEMPERATURES °F (°C)

EDB °F (°C)	EVAP AIR EWB °F (°C)	125 (46.1)			115 (46.1)			105 (40.6)			95 (35)			85 (29.4)			75 (23.9)			65 (18.3)									
		ID SCFM	Capacity MBtuh†		Total Sys. KW**	ID SCFM	Capacity MBtuh		Total Sys. KW**	ID SCFM	Capacity MBtuh		Total Sys. KW**	ID SCFM	Capacity MBtuh		Total Sys. KW**	ID SCFM	Capacity MBtuh		Total Sys. KW**	ID SCFM	Capacity MBtuh		Total Sys. KW**				
			Total	Sens‡			Total	Sens‡			Total	Sens‡			Total	Sens‡			Total	Sens‡			Total	Sens‡		Total	Sens‡	Total	Sens‡
<b>MAXIMUM DEMAND</b>																													
75 (23.9)	72 (22.2)	630	20.65	8.49	2.39	630	22.32	9.10	2.11	640	23.79	9.65	1.86	650	25.11	10.16	1.63	650	26.39	10.64	1.43	700	27.22	11.00	1.32	680	27.13	10.95	1.34
	67 (19.4)		18.67	11.49	2.37		20.17	12.10	2.10		21.50	12.70	1.85		22.74	13.27	1.63		23.95	13.78	1.44		24.91	14.44	1.34		25.00	14.37	1.34
	63 (17.2)		17.18	13.84	2.35		18.54	14.43	2.08		19.78	15.07	1.84		20.94	15.68	1.63		22.05	16.19	1.45		23.04	17.07	1.35		23.24	16.98	1.33
	57 (13.9)		15.96	15.96	2.33		16.96	16.96	2.06		17.93	17.93	1.82		19.06	18.35	1.62		19.66	19.58	1.46		20.97	20.05	1.35		21.53	19.23	1.32
80 (26.7)	72 (22.2)	630	20.56	11.51	2.39	630	22.23	12.12	2.11	640	23.70	12.73	1.86	650	25.01	13.28	1.63	650	26.30	13.77	1.43	700	27.12	14.34	1.32	680	27.03	14.20	1.34
	67 (19.4)		18.60	14.48	2.37		20.10	15.09	2.10		21.43	15.74	1.85		22.67	16.35	1.63		23.88	16.86	1.44		24.84	17.75	1.34		24.93	17.59	1.34
	63 (17.2)		17.36	16.50	2.36		18.56	17.38	2.08		19.79	18.08	1.84		20.94	18.74	1.63		22.04	19.25	1.45		23.04	20.36	1.35		23.22	20.18	1.33
	57 (13.9)		17.03	17.03	2.35		18.09	18.09	2.07		19.10	19.10	1.83		20.04	20.04	1.63		20.87	20.87	1.46		21.97	21.97	1.35		22.06	22.06	1.33
<b>MEDIAN DEMAND</b>																													
75 (23.9)	72 (22.2)	465	17.83	7.24	2.00	465	19.37	7.83	1.79	470	20.53	8.28	1.65	475	18.99	7.69	1.14	475	19.48	7.88	0.96	500	19.77	8.01	0.84	490	19.62	7.94	0.86
	67 (19.4)		16.11	9.48	1.98		17.47	10.05	1.78		18.55	10.54	1.64		17.21	10.00	1.15		17.73	10.22	0.98		18.12	10.52	0.86		18.11	10.46	0.87
	63 (17.2)		14.82	11.22	1.96		16.06	11.78	1.77		17.07	12.29	1.63		15.84	11.78	1.16		16.34	12.00	0.99		16.80	12.44	0.87		16.88	12.39	0.87
	57 (13.9)		13.37	13.37	1.94		14.52	13.80	1.75		15.58	14.06	1.62		14.18	14.18	1.16		14.80	14.06	1.00		15.25	14.66	0.88		15.35	14.76	0.87
80 (26.7)	72 (22.2)	465	17.75	9.52	2.00	465	19.31	10.09	1.79	470	20.46	10.57	1.65	475	18.91	10.01	1.14	475	19.41	10.19	0.96	500	19.69	10.43	0.84	490	19.51	10.31	0.86
	67 (19.4)		16.06	11.71	1.98		17.43	12.29	1.78		18.50	12.79	1.64		17.16	12.28	1.15		17.68	12.50	0.98		18.06	12.91	0.86		18.05	12.81	0.87
	63 (17.2)		14.81	13.44	1.96		16.05	14.01	1.77		17.05	14.54	1.63		15.83	14.04	1.16		16.33	14.27	0.99		16.79	14.83	0.87		16.87	14.72	0.87
	57 (13.9)		14.25	14.25	1.95		15.18	15.18	1.76		15.97	15.97	1.62		15.09	15.09	1.16		15.47	15.47	0.99		16.00	16.00	0.88		16.05	16.05	0.87
<b>MINIMUM DEMAND</b>																													
75 (23.9)	72 (22.2)	300	14.29	5.75	1.68	300	15.46	6.23	1.50	300	16.22	6.55	1.36	300	12.68	5.12	0.75	300	12.01	4.87	0.60	300	12.14	4.92	0.46	300	12.03	4.87	0.49
	67 (19.4)		12.90	7.20	1.65		13.90	7.64	1.49		14.63	7.97	1.35		11.39	6.54	0.76		10.86	6.33	0.61		11.09	6.42	0.48		11.06	6.41	0.51
	63 (17.2)		11.85	8.31	1.63		12.75	8.74	1.47		13.45	9.08	1.33		10.43	7.65	0.77		9.97	7.44	0.62		10.19	7.54	0.50		10.23	7.56	0.52
	57 (13.9)		10.43	9.93	1.60		11.20	10.34	1.45		11.83	10.68	1.31		9.21	9.21	0.78		8.91	8.91	0.63		9.05	9.05	0.51		9.16	9.16	0.52
80 (26.7)	72 (22.2)	300	14.26	7.22	1.68	300	15.42	7.69	1.50	300	16.19	8.01	1.36	300	12.63	6.58	0.75	300	11.96	6.33	0.60	300	12.09	6.38	0.46	300	11.85	6.28	0.49
	67 (19.4)		12.87	8.65	1.65		13.87	9.10	1.49		14.61	9.42	1.35		11.35	8.00	0.76		10.83	7.78	0.61		11.06	7.87	0.48		11.03	7.86	0.51
	63 (17.2)		11.83	9.76	1.63		12.73	10.19	1.47		13.43	10.53	1.33		10.41	9.10	0.77		9.96	8.89	0.62		10.18	8.99	0.50		10.22	9.01	0.52
	57 (13.9)		10.87	10.87	1.61		11.49	11.49	1.45		11.98	11.98	1.31		9.83	9.83	0.77		9.51	9.51	0.62		9.66	9.66	0.50		9.73	9.73	0.52

See notes on page 22

15 Manufacturer reserves the right to change, at any time, specifications and designs without notice and without obligations.

# Detailed Cooling Capacities# - Comfort + Dehumidify Mode (cont.)

25VNA436/FE4ANB005 COOLING COMFORT + DEHUMIDIFY MODE CONDENSER ENTERING AIR TEMPERATURES °F (°C)

EDB °F (°C)	EVAP. AIR EWB °F (°C)	125 (46.1)			115 (46.1)			105 (40.6)			95 (35)			85 (29.4)			75 (23.9)			65 (18.3)									
		ID SCFM	Capacity MBtuh†		Total Sys. KW**	ID SCFM	Capacity MBtuh		Total Sys. KW**	ID SCFM	Capacity MBtuh		Total Sys. KW**	ID SCFM	Capacity MBtuh		Total Sys. KW**	ID SCFM	Capacity MBtuh		Total Sys. KW**	ID SCFM	Capacity MBtuh		Total Sys. KW**				
			Total	Sens)‡			Total	Sens)‡			Total	Sens)‡			Total	Sens)‡			Total	Sens)‡			Total	Sens)‡		Total	Sens)‡	Total	Sens)‡
<b>MAXIMUM DEMAND</b>																													
75 (23.9)	72 (22.2)	650	26.89	10.51	3.15	650	28.47	11.12	2.80	680	29.78	11.63	2.44	750	32.27	12.60	2.22	750	32.23	12.59	1.84	450	28.31	11.35	1.43	450	27.77	11.11	1.39
	67 (19.4)		23.99	13.53	3.15		25.40	14.14	2.80		26.59	14.79	2.44		28.86	16.11	2.23		28.87	16.11	1.86		25.34	13.38	1.45		24.95	13.19	1.38
	63 (17.2)		21.87	15.88	3.14		23.14	16.47	2.79		24.27	17.25	2.44		26.37	18.83	2.24		26.40	18.84	1.87		23.18	14.96	1.45		22.90	14.79	1.37
	57 (13.9)		19.21	19.21	3.11		20.23	19.91	2.78		22.05	19.63	2.44		23.18	22.82	2.24		23.23	22.85	1.88		20.30	17.28	1.46		20.09	17.16	1.35
80 (26.7)	72 (22.2)	650	26.80	13.67	3.15	650	28.38	14.28	2.80	680	29.70	14.93	2.44	750	32.17	16.28	2.22	750	32.15	16.24	1.84	450	28.27	13.55	1.43	450	27.73	13.31	1.39
	67 (19.4)		23.92	16.66	3.15		25.31	17.25	2.79		26.52	18.06	2.44		28.79	19.71	2.23		28.80	19.71	1.86		25.30	15.56	1.45		24.92	15.38	1.38
	63 (17.2)		21.85	19.00	3.14		23.11	19.59	2.79		24.24	20.51	2.44		26.35	22.42	2.24		26.38	22.43	1.87		23.14	17.13	1.45		22.85	16.98	1.37
	57 (13.9)		20.56	20.56	3.13		21.48	21.48	2.78		22.53	22.53	2.44		24.59	24.59	2.24		24.64	24.64	1.87		19.45	19.45	1.46		20.13	19.34	1.35
<b>MEDIAN DEMAND</b>																													
75 (23.9)	72 (22.2)	480	20.98	8.20	2.33	480	21.41	8.36	1.95	490	21.75	8.50	1.63	515	22.99	8.98	1.42	515	22.41	8.76	1.13	350	20.78	8.24	0.99	350	20.06	7.92	0.96
	67 (19.4)		18.64	10.44	2.33		19.01	10.61	1.96		19.35	10.80	1.64		20.50	11.42	1.44		20.02	11.21	1.15		18.59	9.87	0.99		18.01	9.59	0.95
	63 (17.2)		16.92	12.19	2.33		17.27	12.35	1.96		17.60	12.59	1.65		18.67	13.33	1.45		18.26	13.13	1.16		16.99	11.14	1.00		16.50	10.89	0.94
	57 (13.9)		14.71	14.71	2.31		15.03	14.94	1.96		15.33	15.24	1.66		17.01	15.11	1.46		16.01	15.95	1.17		14.83	12.99	1.00		14.47	12.78	0.93
80 (26.7)	72 (22.2)	480	20.92	10.58	2.33	480	21.34	10.75	1.95	490	21.68	10.93	1.63	515	22.92	11.54	1.42	515	22.34	11.32	1.14	350	20.75	9.98	0.99	350	20.02	9.66	0.96
	67 (19.4)		18.59	12.81	2.33		18.96	12.97	1.96		19.29	13.22	1.64		20.45	13.96	1.44		19.97	13.76	1.15		18.56	11.60	0.99		17.97	11.32	0.95
	63 (17.2)		16.89	14.55	2.33		17.25	14.72	1.96		17.57	15.00	1.65		18.65	15.86	1.45		18.25	15.67	1.16		16.96	12.86	1.00		16.47	12.61	0.94
	57 (13.9)		15.81	15.81	2.32		16.06	16.06	1.96		16.37	16.37	1.65		17.36	17.36	1.46		17.09	17.09	1.17		14.71	14.71	1.00		14.51	14.50	0.93
<b>MINIMUM DEMAND</b>																													
75 (23.9)	72 (22.2)	400	16.87	6.59	2.05	400	17.12	6.69	1.70	400	16.80	6.56	1.36	400	17.15	6.70	1.13	400	16.32	6.38	0.90	300	15.67	6.16	0.92	300	15.43	6.06	0.86
	67 (19.4)		14.96	8.37	2.05		15.18	8.47	1.71		14.90	8.34	1.37		15.24	8.50	1.15		14.55	8.20	0.92		14.01	7.52	0.91		13.85	7.44	0.84
	63 (17.2)		13.55	9.77	2.05		13.74	9.88	1.71		13.51	9.75	1.38		13.84	9.91	1.16		13.22	9.62	0.93		12.78	8.57	0.91		12.67	8.52	0.83
	57 (13.9)		11.76	11.76	2.04		11.90	11.90	1.71		11.77	11.77	1.39		12.04	11.98	1.17		11.61	11.61	0.94		11.15	10.11	0.90		11.08	10.08	0.81
80 (26.7)	72 (22.2)	400	16.82	8.50	2.05	400	17.06	8.59	1.70	400	16.75	8.47	1.36	400	17.09	8.61	1.13	400	16.26	8.29	0.90	300	15.63	7.60	0.92	300	15.39	7.50	0.86
	67 (19.4)		14.90	10.27	2.05		15.12	10.36	1.71		14.85	10.25	1.37		15.20	10.40	1.15		14.51	10.11	0.92		13.98	8.94	0.91		13.82	8.87	0.84
	63 (17.2)		13.52	11.66	2.05		13.72	11.75	1.71		13.49	11.65	1.38		13.83	11.80	1.16		13.23	11.52	0.93		12.76	9.99	0.91		12.64	9.95	0.83
	57 (13.9)		12.62	12.62	2.04		12.78	12.78	1.71		12.62	12.62	1.39		12.87	12.87	1.17		12.44	12.44	0.93		11.35	11.35	0.90		11.29	11.29	0.81

See notes on page 22

16 Manufacturer reserves the right to change, at any time, specifications and designs without notice and without obligations.

# Detailed Cooling Capacities# - Comfort + Dehumidify Mode (cont.)

25VNA448/FE4ANB006 Cooling COMFORT + DEHUIDIFY MODE CONDENSER ENTERING AIR TEMPERATURES °F (°C)

EDB °F (°C)	EVAP. AIR EWB °F (°C)	125 (46.1)			115 (46.1)			105 (40.6)			95 (35)			85 (29.4)			75 (23.9)			65 (18.3)									
		ID SCFM	Capacity MBtuh†		Total Sys. KW**	ID SCFM	Capacity MBtuh		Total Sys. KW**	ID SCFM	Capacity MBtuh		Total Sys. KW**	ID SCFM	Capacity MBtuh		Total Sys. KW**	ID SCFM	Capacity MBtuh		Total Sys. KW**	ID SCFM	Capacity MBtuh		Total Sys. KW**				
			Total	Sens)‡			Total	Sens)‡			Total	Sens)‡			Total	Sens)‡			Total	Sens)‡			Total	Sens)‡		Total	Sens)‡	Total	Sens)‡
<b>MAXIMUM DEMAND</b>																													
75 (23.9)	72 (22.2)	900	38.63	15.56	4.22	1000	43.06	17.33	3.86	1000	45.77	18.39	3.47	1100	49.21	19.73	3.13	1200	52.23	20.91	2.81	1200	53.76	21.51	2.63	1200	55.15	22.06	2.51
	67 (19.4)		34.98	19.99	4.16		38.81	22.16	3.81		41.32	23.24	3.45		44.55	25.12	3.13		47.48	26.86	2.82		49.18	27.60	2.63		50.73	28.27	2.50
	63 (17.2)		32.26	23.43	4.11		35.66	25.91	3.77		37.98	26.98	3.42		40.99	29.25	3.12		43.81	31.41	2.83		45.53	32.21	2.62		47.15	32.97	2.49
	57 (13.9)		29.00	27.80	4.04		31.61	31.36	3.71		33.62	32.49	3.38		36.34	35.29	3.10		38.93	37.99	2.82		40.57	38.89	2.60		42.13	39.75	2.45
80 (26.7)	72 (22.2)	900	38.47	19.99	4.22	1000	42.94	22.26	3.86	1000	45.65	23.32	3.47	1100	49.07	25.15	3.13	1200	52.05	26.79	2.81	1200	53.59	27.40	2.63	1200	54.98	27.95	2.51
	67 (19.4)		34.91	24.38	4.16		38.72	27.03	3.81		41.24	28.11	3.45		44.46	30.46	3.13		47.37	32.67	2.82		49.07	33.41	2.63		50.62	34.09	2.50
	63 (17.2)		32.22	27.80	4.11		35.63	30.76	3.77		37.94	31.84	3.42		40.95	34.57	3.12		43.77	37.21	2.83		45.48	38.01	2.62		47.09	38.77	2.49
	57 (13.9)		30.33	30.33	4.07		33.52	33.52	3.74		35.24	35.24	3.40		38.17	38.17	3.11		40.96	40.96	2.82		42.32	42.32	2.61		43.62	43.62	2.46
<b>MEDIAN DEMAND</b>																													
75 (23.9)	72 (22.2)	800	34.63	13.96	3.62	800	37.69	15.15	3.27	800	37.46	15.06	2.63	800	36.80	14.81	2.05	850	35.45	14.32	1.54	850	36.28	14.64	1.35	850	37.32	15.03	1.13
	67 (19.4)		31.31	17.93	3.57		33.90	19.04	3.24		33.78	19.04	2.62		33.33	18.87	2.07		32.59	18.80	1.57		33.84	19.38	1.41		34.87	19.81	1.19
	63 (17.2)		28.82	20.99	3.53		31.12	22.06	3.21		31.06	22.05	2.61		30.64	21.94	2.07		30.11	22.20	1.59		31.48	22.86	1.43		32.82	23.48	1.23
	57 (13.9)		25.46	25.39	3.47		27.44	26.49	3.16		27.40	26.55	2.58		27.08	26.45	2.07		26.86	26.86	1.60		28.07	27.76	1.44		29.39	28.49	1.26
80 (26.7)	72 (22.2)	800	34.48	17.93	3.62	800	37.59	19.15	3.27	800	37.36	19.09	2.63	800	36.68	18.85	2.05	850	35.24	18.61	1.53	850	36.13	18.95	1.35	850	37.13	19.34	1.13
	67 (19.4)		31.21	21.86	3.57		33.83	22.99	3.24		33.71	23.00	2.62		33.25	22.87	2.07		32.48	23.12	1.57		33.76	23.66	1.40		34.74	24.08	1.19
	63 (17.2)		28.78	24.93	3.53		31.08	26.00	3.21		31.02	26.02	2.61		30.62	25.92	2.07		30.09	26.48	1.59		31.45	27.12	1.43		32.78	27.74	1.23
	57 (13.9)		27.12	27.12	3.50		28.76	28.76	3.18		28.77	28.77	2.59		28.53	28.53	2.07		28.60	28.60	1.60		29.69	29.69	1.44		30.78	30.78	1.25
<b>MINIMUM DEMAND</b>																													
75 (23.9)	72 (22.2)	700	31.04	12.49	3.19	700	33.60	13.50	2.87	600	29.44	11.86	1.96	500	24.23	9.78	1.23	500	24.48	9.88	0.99	500	24.49	9.88	0.77	500	23.88	9.64	0.56
	67 (19.4)		28.00	15.97	3.16		30.21	16.92	2.84		26.46	14.82	1.96		21.81	12.30	1.25		22.31	12.52	1.02		22.64	12.67	0.81		22.38	12.56	0.62
	63 (17.2)		25.71	18.66	3.13		27.70	19.58	2.82		24.25	17.13	1.95		19.93	14.23	1.26		20.45	14.48	1.04		20.92	14.71	0.84		21.14	14.82	0.66
	57 (13.9)		22.67	22.56	3.08		24.36	23.48	2.78		21.30	20.51	1.94		17.45	17.07	1.27		17.92	17.32	1.05		18.37	17.57	0.86		18.74	17.78	0.70
80 (26.7)	72 (22.2)	700	30.92	16.01	3.19	700	33.51	17.02	2.87	600	29.36	14.92	1.96	500	24.14	12.36	1.23	500	24.35	12.45	0.99	500	24.31	12.43	0.76	500	23.59	12.15	0.55
	67 (19.4)		27.92	19.46	3.16		30.14	20.42	2.84		26.38	17.88	1.96		21.75	14.87	1.25		22.25	15.10	1.02		22.58	15.25	0.81		22.32	15.14	0.62
	63 (17.2)		25.67	22.14	3.13		27.66	23.06	2.82		24.21	20.16	1.95		19.91	16.79	1.26		20.42	17.05	1.04		20.89	17.28	0.84		21.11	17.39	0.66
	57 (13.9)		24.11	24.11	3.10		25.53	25.53	2.79		22.32	22.32	1.94		18.44	18.44	1.26		18.83	18.83	1.05		19.20	19.20	0.85		19.49	19.49	0.69

See notes on page 22

Manufacturer reserves the right to change, at any time, specifications and designs without notice and without obligations.

# Detailed Cooling Capacities# - Comfort + Dehumidify Mode (cont.)

## 25VNA460/FE4ANB006 Cooling COMFORT + DEHUIDIFY MODE CONDENSER ENTERING AIR TEMPERATURES °F (°C)

EDB °F (°C)	EVAP. AIR EWB °F (°C)	125 (46.1)				115 (46.1)				105 (40.6)				95 (35)				85 (29.4)				75 (23.9)				65 (18.3)			
		ID SCFM	Capacity MBtuh†		Total Sys. KW**	ID SCFM	Capacity MBtuh		Total Sys. KW**	ID SCFM	Capacity MBtuh		Total Sys. KW**	ID SCFM	Capacity MBtuh		Total Sys. KW**	ID SCFM	Capacity MBtuh		Total Sys. KW**	ID SCFM	Capacity MBtuh		Total Sys. KW**	ID SCFM	Capacity MBtuh		Total Sys. KW**
			Total	Sens‡			Total	Sens‡			Total	Sens‡			Total	Sens‡			Total	Sens‡			Total	Sens‡			Total	Sens‡	
<b>MAXIMUM DEMAND</b>																													
75 (23.9)	72 (22.2)	1000	45.72	18.30	5.49	1125	51.31	20.52	4.97	1250	55.44	22.14	4.43	1250	58.33	23.27	3.93	1400	62.41	24.86	3.60	1400	65.06	25.90	3.16	1400	67.33	26.79	2.78
	67 (19.4)		41.87	23.52	5.46		46.61	26.21	4.95		50.38	28.44	4.41		52.99	29.58	3.92		56.81	31.95	3.59		59.25	33.01	3.16		61.37	33.95	2.77
	63 (17.2)		38.89	27.54	5.44		43.08	30.62	4.93		46.56	33.32	4.40		48.97	34.44	3.90		52.53	37.41	3.59		54.80	38.47	3.16		56.83	39.43	2.77
	57 (13.9)		34.93	33.46	5.40		38.53	37.12	4.90		41.69	40.48	4.38		43.79	41.63	3.89		47.05	45.40	3.58		49.04	46.51	3.16		50.87	47.51	2.77
80 (26.7)	72 (22.2)	1000	45.51	23.30	5.49	1125	51.15	26.16	4.97	1250	55.29	28.39	4.43	1250	58.19	29.53	3.93	1400	62.24	31.85	3.60	1400	64.89	32.90	3.16	1400	67.16	33.80	2.78
	67 (19.4)		41.75	28.48	5.47		46.51	31.78	4.95		50.27	34.61	4.41		52.90	35.75	3.92		57.23	39.08	3.62		59.67	40.14	3.19		61.75	41.06	2.80
	63 (17.2)		38.83	32.49	5.44		43.02	36.17	4.93		46.51	39.45	4.40		48.91	40.59	3.90		52.47	44.26	3.59		54.74	45.33	3.16		56.76	46.30	2.77
	57 (13.9)		36.20	36.20	5.41		40.10	40.10	4.91		43.55	43.55	4.39		45.33	45.33	3.89		49.04	49.04	3.58		50.73	50.73	3.16		52.23	52.23	2.76
<b>MEDIAN DEMAND</b>																													
75 (23.9)	72 (22.2)	900	42.80	17.14	4.85	1000	48.11	19.25	4.37	1000	47.98	19.20	3.54	950	45.76	18.31	2.73	900	44.99	18.01	2.21	900	46.00	18.41	1.84	900	47.45	19.00	1.61
	67 (19.4)		39.32	22.08	4.83		43.76	24.54	4.35		43.62	24.48	3.53		41.62	23.35	2.74		40.87	22.76	2.23		41.86	23.19	1.86		43.33	23.84	1.62
	63 (17.2)		35.98	25.58	4.80		40.50	28.64	4.33		40.34	28.56	3.53		38.50	27.23	2.74		37.73	26.41	2.24		38.67	26.85	1.87		40.11	27.55	1.63
	57 (13.9)		32.16	31.04	4.76		35.45	34.26	4.29		35.29	34.17	3.50		33.63	32.54	2.73		33.52	31.75	2.25		34.34	32.19	1.89		35.67	32.91	1.63
80 (26.7)	72 (22.2)	900	42.50	21.78	4.85	1000	47.94	24.46	4.37	1000	47.83	24.42	3.54	950	45.60	23.24	2.73	900	44.86	22.72	2.21	900	45.86	23.11	1.84	900	47.31	23.70	1.61
	67 (19.4)		39.20	26.71	4.83		43.64	29.68	4.35		43.50	29.62	3.53		41.53	28.25	2.74		40.79	27.41	2.23		41.77	27.85	1.86		43.24	28.50	1.62
	63 (17.2)		36.53	30.50	4.81		40.44	33.77	4.33		40.29	33.70	3.53		38.45	32.12	2.74		37.68	31.04	2.24		38.62	31.49	1.87		40.06	32.18	1.63
	57 (13.9)		34.08	34.08	4.79		37.62	37.62	4.31		37.50	37.50	3.52		35.76	35.76	2.74		34.77	34.77	2.25		35.46	35.46	1.88		36.54	36.54	1.63
<b>MINIMUM DEMAND</b>																													
75 (23.9)	72 (22.2)	800	38.25	15.34	4.22	875	42.98	17.22	3.78	750	37.13	14.88	2.59	600	28.70	11.52	1.59	500	25.33	10.15	1.15	500	24.54	9.84	0.85	500	25.13	10.07	0.75
	67 (19.4)		35.11	19.87	4.21		39.08	22.01	3.77		33.67	18.96	2.60		25.94	14.75	1.61		22.83	12.81	1.17		22.23	12.55	0.88		23.01	12.89	0.78
	63 (17.2)		32.68	23.37	4.20		36.14	25.72	3.76		31.06	22.12	2.61		23.86	17.26	1.63		20.97	14.88	1.18		20.39	14.63	0.90		21.20	14.99	0.79
	57 (13.9)		29.20	28.39	4.17		32.14	31.12	3.74		27.53	26.72	2.61		21.10	20.92	1.65		18.46	17.91	1.20		17.98	17.66	0.92		18.73	18.05	0.80
80 (26.7)	72 (22.2)	800	38.38	19.77	4.22	875	43.18	22.08	3.79	750	37.34	19.07	2.60	600	28.92	14.89	1.60	500	25.57	12.98	1.15	500	24.57	12.59	0.85	500	25.05	12.77	0.75
	67 (19.4)		35.45	24.34	4.22		39.57	26.95	3.79		34.21	23.25	2.62		26.50	18.24	1.62		23.11	15.65	1.17		22.50	15.38	0.88		23.20	15.69	0.78
	63 (17.2)		32.93	27.78	4.20		36.44	30.55	3.76		31.37	26.29	2.61		24.16	20.62	1.63		21.27	17.72	1.19		20.72	17.46	0.90		21.51	17.83	0.79
	57 (13.9)		30.58	30.58	4.18		33.75	33.75	3.75		28.98	28.98	2.61		22.46	22.46	1.64		19.50	19.50	1.20		19.09	19.09	0.91		19.70	19.70	0.80

See notes on page 22

Manufacturer reserves the right to change, at any time, specifications and designs without notice and without obligations.

# Detailed Cooling Capacities# - Cooling Efficiency Mode

## 25VNA424/FE4ANB002 COOLING EFFICIENCY MODE CONDENSER ENTERING AIR TEMPERATURES deg °F (°C)

EDB °F (°C)	EVAPORATOR AIR EWB °F (°C)	125 (46.1)			115 (46.1)			105 (40.6)			95 (35)			85 (29.4)			75 (23.9)			65 (18.3)									
		ID SCFM	Capacity MBtuh†		Total Sys. KW**	ID SCFM	Capacity MBtuh		Total Sys. KW**	ID SCFM	Capacity MBtuh		Total Sys. KW**	ID SCFM	Capacity MBtuh		Total Sys. KW**	ID SCFM	Capacity MBtuh		Total Sys. KW**	ID SCFM	Capacity MBtuh		Total Sys. KW**				
			Total	Sens‡			Total	Sens‡			Total	Sens‡			Total	Sens‡			Total	Sens‡			Total	Sens‡		Total	Sens‡		
<b>MAXIMUM DEMAND</b>																													
75 (23.9)	72 (22.2)	630	20.65	8.49	2.39	630	22.32	9.10	2.11	640	23.79	9.65	1.86	650	25.11	10.16	1.63	650	26.39	10.64	1.43	700	27.22	11.00	1.32	680	27.13	10.95	1.34
	67 (19.4)		18.67	11.49	2.37		20.17	12.10	2.10		21.50	12.70	1.85		22.74	13.27	1.63		23.95	13.78	1.44		24.91	14.44	1.34		25.00	14.37	1.34
	63 (17.2)		17.18	13.84	2.35		18.54	14.43	2.08		19.78	15.07	1.84		20.94	15.68	1.63		22.05	16.19	1.45		23.04	17.07	1.35		23.24	16.98	1.33
	57 (13.9)		15.96	15.96	2.33		16.96	16.96	2.06		17.93	17.93	1.82		19.06	18.35	1.62		19.66	19.58	1.46		20.97	20.05	1.35		21.53	19.23	1.32
80 (26.7)	72 (22.2)	630	20.56	11.51	2.39	630	22.23	12.12	2.11	640	23.70	12.73	1.86	650	25.01	13.28	1.63	650	26.30	13.77	1.43	700	27.12	14.34	1.32	680	27.03	14.20	1.34
	67 (19.4)		18.60	14.48	2.37		20.10	15.09	2.10		21.43	15.74	1.85		22.67	16.35	1.63		23.88	16.86	1.44		24.84	17.75	1.34		24.93	17.59	1.34
	63 (17.2)		17.36	16.50	2.36		18.56	17.38	2.08		19.79	18.08	1.84		20.94	18.74	1.63		22.04	19.25	1.45		23.04	20.36	1.35		23.22	20.18	1.33
	57 (13.9)		17.03	17.03	2.35		18.09	18.09	2.07		19.10	19.10	1.83		20.04	20.04	1.63		20.87	20.87	1.46		21.97	21.97	1.35		22.06	22.06	1.33
<b>MEDIAN DEMAND</b>																													
75 (23.9)	72 (22.2)	750	18.90	8.05	2.07	750	20.58	8.63	1.86	750	21.84	9.08	1.64	740	19.88	8.37	1.19	740	17.89	7.68	0.87	740	18.75	7.98	0.72	730	18.83	7.99	0.64
	67 (19.4)		17.11	11.60	2.06		18.62	12.18	1.85		19.82	12.65	1.64		18.13	11.93	1.20		16.34	11.25	0.90		17.05	11.52	0.75		17.22	11.53	0.67
	63 (17.2)		15.80	14.35	2.04		17.16	14.94	1.84		18.28	15.43	1.63		16.76	14.67	1.21		15.35	12.59	0.91		15.96	14.32	0.78		16.21	14.34	0.69
	57 (13.9)		15.35	15.35	2.03		16.43	16.43	1.83		17.32	17.32	1.63		16.09	16.09	1.21		14.85	14.85	0.92		15.49	15.49	0.79		15.70	15.70	0.70
80 (26.7)	72 (22.2)	750	18.78	11.60	2.07	750	20.47	12.19	1.86	750	21.74	12.65	1.64	740	19.77	11.89	1.19	740	17.77	11.19	0.87	740	18.63	11.49	0.72	730	18.72	11.46	0.64
	67 (19.4)		17.06	15.09	2.06		18.56	15.69	1.85		19.76	16.17	1.64		18.08	15.39	1.20		16.31	14.67	0.90		17.00	14.96	0.75		17.14	14.91	0.66
	63 (17.2)		16.44	16.44	2.05		17.61	17.61	1.85		18.90	17.45	1.63		17.23	17.23	1.21		15.86	15.86	0.90		16.49	16.49	0.76		16.62	16.62	0.68
	57 (13.9)		16.42	16.42	2.05		17.58	17.58	1.85		18.49	18.49	1.63		17.20	17.20	1.21		15.84	15.84	0.90		16.46	16.46	0.76		16.60	16.60	0.68
<b>MINIMUM DEMAND</b>																													
75 (23.9)	72 (22.2)	900	21.32	9.10	2.49	900	23.17	9.74	2.20	900	24.68	10.27	1.94	850	25.90	10.65	1.69	850	27.30	11.16	1.48	850	28.59	11.63	1.27	825	27.68	11.27	1.39
	67 (19.4)		19.29	13.31	2.47		20.96	13.95	2.19		22.38	14.50	1.94		23.56	14.69	1.69		24.87	15.21	1.50		26.07	15.70	1.31		25.56	15.36	1.39
	63 (17.2)		17.82	16.54	2.45		19.33	17.21	2.18		20.64	17.78	1.93		21.73	17.81	1.69		22.94	18.34	1.51		24.10	18.86	1.33		23.85	18.52	1.38
	57 (13.9)		17.43	17.43	2.45		18.64	18.64	2.17		19.69	19.69	1.92		20.36	20.36	1.69		21.29	21.29	1.51		22.14	22.14	1.35		22.02	22.02	1.38
80 (26.7)	72 (22.2)	900	21.18	13.31	2.49	900	23.04	13.95	2.20	900	24.54	14.49	1.94	850	25.78	14.66	1.69	850	27.18	15.17	1.48	850	28.48	15.64	1.27	825	27.10	14.99	1.37
	67 (19.4)		19.25	17.42	2.47		20.90	18.09	2.19		22.31	18.65	1.94		23.48	18.65	1.69		24.78	19.18	1.50		25.99	19.67	1.31		25.47	19.21	1.39
	63 (17.2)		18.68	18.68	2.46		19.99	19.99	2.18		21.54	19.65	1.93		21.89	21.55	1.69		23.43	22.37	1.51		24.61	22.94	1.34		24.40	22.54	1.38
	57 (13.9)		18.66	18.66	2.46		19.96	19.96	2.18		21.21	21.21	1.93		21.73	21.73	1.69		22.70	22.70	1.51		23.60	23.60	1.34		23.32	23.32	1.38

See notes on page 22

Manufacturer reserves the right to change, at any time, specifications and designs without notice and without obligations.

# Detailed Cooling Capacities# - Cooling Efficiency Mode (cont.)

## 25VNA436/FE4ANB005 COOLING EFFICIENCY MODE CONDENSER ENTERING AIR TEMPERATURES deg °F (°C)

EDB °F (°C)	EVAPORATOR AIR EWB °F (°C)	125 (46.1)			115 (46.1)			105 (40.6)			95 (35)			85 (29.4)			75 (23.9)			65 (18.3)									
		ID SCFM	Capacity MBtuh†		Total Sys. KW**	ID SCFM	Capacity MBtuh		Total Sys. KW**	ID SCFM	Capacity MBtuh		Total Sys. KW**	ID SCFM	Capacity MBtuh		Total Sys. KW**	ID SCFM	Capacity MBtuh		Total Sys. KW**	ID SCFM	Capacity MBtuh		Total Sys. KW**				
			Total	Sens‡			Total	Sens‡			Total	Sens‡			Total	Sens‡			Total	Sens‡			Total	Sens‡		Total	Sens‡		
<b>MAXIMUM DEMAND</b>																													
75 (23.9)	72 (22.2)	1100	30.93	12.40	3.62	1100	33.40	13.29	3.30	1100	35.75	14.13	3.00	1100	37.97	14.95	2.69	1100	40.24	15.79	2.44	900	40.64	15.88	2.17	650	38.95	15.49	1.92
	67 (19.4)		27.59	17.52	3.62		29.82	18.39	3.30		31.97	19.25	3.01		34.02	20.08	2.70		36.13	20.94	2.45		36.49	20.11	2.17		34.99	18.50	1.91
	63 (17.2)		25.17	21.52	3.61		27.23	22.40	3.30		29.22	23.26	3.02		31.12	24.09	2.70		33.06	24.95	2.46		33.47	23.41	2.17		32.08	20.84	1.91
	57 (13.9)		23.90	23.90	3.61		25.47	25.47	3.30		26.97	26.97	3.02		28.40	28.40	2.70		29.84	29.84	2.46		29.52	28.23	2.16		28.21	24.26	1.89
80 (26.7)	72 (22.2)	1100	30.79	17.65	3.62	1100	33.28	18.54	3.29	1100	35.64	19.39	3.00	1100	37.88	20.22	2.69	1100	40.17	21.08	2.44	900	40.56	20.26	2.17	650	38.90	18.66	1.92
	67 (19.4)		27.51	22.70	3.62		29.72	23.59	3.30		31.87	24.47	3.01		33.93	25.28	2.70		36.02	26.15	2.45		36.44	24.43	2.17		34.93	21.64	1.91
	63 (17.2)		25.76	25.76	3.61		27.48	27.32	3.30		29.35	28.35	3.02		31.22	29.22	2.70		33.13	30.10	2.46		33.44	27.70	2.17		32.05	23.97	1.91
	57 (13.9)		25.71	25.71	3.61		27.36	27.36	3.30		28.93	28.93	3.02		30.40	30.40	2.70		31.90	31.90	2.46		30.86	30.86	2.16		28.29	27.39	1.90
<b>MEDIAN DEMAND</b>																													
75 (23.9)	72 (22.2)	800	25.65	10.17	2.88	800	27.69	10.91	2.58	800	29.64	11.64	2.32	800	31.46	12.32	2.07	800	25.26	10.04	1.38	525	24.74	9.67	1.20	465	24.84	9.79	1.13
	67 (19.4)		22.82	13.96	2.89		24.67	14.70	2.60		26.45	15.42	2.34		28.13	16.12	2.08		22.77	13.95	1.39		22.16	12.16	1.21		22.33	12.00	1.13
	63 (17.2)		20.77	16.91	2.89		22.47	17.66	2.60		24.13	18.39	2.34		25.70	19.09	2.09		20.81	16.94	1.40		20.29	14.12	1.21		20.46	13.72	1.12
	57 (13.9)		19.28	19.28	2.89		20.55	20.55	2.60		21.77	21.77	2.35		22.92	22.92	2.09		19.36	19.36	1.41		17.81	16.98	1.22		17.97	16.23	1.12
80 (26.7)	72 (22.2)	800	25.54	14.10	2.88	800	27.58	14.84	2.58	800	29.54	15.57	2.32	800	31.37	16.26	2.07	800	25.16	14.01	1.38	525	24.68	12.27	1.20	465	24.79	12.08	1.13
	67 (19.4)		22.74	17.83	2.89		24.59	18.58	2.60		26.37	19.31	2.34		28.06	20.01	2.08		22.71	17.83	1.39		22.12	14.74	1.21		22.28	14.27	1.13
	63 (17.2)		20.96	20.53	2.89		22.55	21.46	2.60		24.16	22.23	2.34		25.71	22.94	2.09		21.14	20.37	1.40		20.26	16.68	1.21		20.43	15.98	1.12
	57 (13.9)		20.75	20.75	2.89		22.07	22.07	2.60		23.34	23.34	2.35		24.52	24.52	2.09		20.80	20.80	1.40		18.61	18.61	1.22		18.35	18.11	1.12
<b>MINIMUM DEMAND</b>																													
75 (23.9)	72 (22.2)	550	19.28	7.57	2.34	550	20.84	8.16	2.06	550	22.31	8.72	1.81	550	23.71	9.26	1.60	550	9.74	4.23	0.55	550	10.48	4.48	0.46	550	10.77	4.50	0.39
	67 (19.4)		17.07	10.06	2.36		18.51	10.65	2.08		19.86	11.22	1.83		21.16	11.78	1.62		8.66	6.83	0.57		9.38	7.09	0.48		9.93	7.28	0.39
	63 (17.2)		15.47	12.01	2.36		16.80	12.60	2.08		18.07	13.17	1.84		19.30	13.73	1.63		8.17	8.17	0.59		8.76	8.76	0.50		9.26	9.26	0.40
	57 (13.9)		14.03	14.03	2.37		14.98	14.98	2.09		15.89	15.89	1.85		16.88	16.61	1.64		8.15	8.15	0.59		8.76	8.76	0.50		9.25	9.25	0.40
80 (26.7)	72 (22.2)	550	19.19	10.19	2.34	550	20.76	10.78	2.06	550	22.24	11.35	1.81	550	23.66	11.90	1.60	550	9.61	6.84	0.55	550	10.39	7.10	0.46	550	10.86	7.24	0.38
	67 (19.4)		17.02	16.75	2.36		18.43	18.43	2.08		19.79	19.79	1.83		21.11	14.38	1.62		8.87	6.19	0.57		9.48	6.82	0.48		10.01	7.45	0.38
	63 (17.2)		30.88	20.52	2.39		16.78	15.19	2.08		18.05	15.77	1.84		19.28	16.33	1.63		8.85	8.85	0.57		9.47	9.47	0.48		9.96	9.96	0.38
	57 (13.9)		15.10	15.10	2.36		16.09	16.09	2.09		17.02	17.02	1.84		17.93	17.93	1.64		8.83	8.83	0.57		9.45	9.45	0.48		9.92	9.92	0.38

See notes on page 22

Manufacturer reserves the right to change, at any time, specifications and designs without notice and without obligations.

# Detailed Cooling Capacities# - Cooling Efficiency Mode (cont.)

## 25VNA448/FE4ANB006 COOLING EFFICIENCY MODE CONDENSER ENTERING AIR TEMPERATURES °F (°C)

EDB °F (°C)	EVAPORATOR AIR EWB °F (°C)	125 (46.1)			115 (46.1)			105 (40.6)			95 (35)			85 (29.4)			75 (23.9)			65 (18.3)									
		ID SCFM	Capacity MBtuh†		Total Sys. KW**	ID SCFM	Capacity MBtuh		Total Sys. KW**	ID SCFM	Capacity MBtuh		Total Sys. KW**	ID SCFM	Capacity MBtuh		Total Sys. KW**	ID SCFM	Capacity MBtuh		Total Sys. KW**	ID SCFM	Capacity MBtuh		Total Sys. KW**				
			Total	Sens‡			Total	Sens‡			Total	Sens‡			Total	Sens‡			Total	Sens‡			Total	Sens‡		Total	Sens‡	Total	Sens‡
<b>MAXIMUM DEMAND</b>																													
75 (23.9)	72 (22.2)	1600	41.05	17.12	4.54	1600	45.49	18.68	4.14	1600	48.60	19.79	3.74	1600	51.54	20.86	3.35	1600	53.94	21.73	2.99	1200	53.75	21.51	2.63	1200	55.17	22.06	2.51
	67 (19.4)		37.36	24.88	4.49		41.24	26.40	4.11		44.18	27.55	3.73		46.94	28.66	3.36		49.34	29.63	3.01		49.18	27.59	2.63		50.71	28.26	2.50
	63 (17.2)		34.59	30.89	4.45		37.95	32.36	4.07		40.70	33.56	3.71		43.31	34.68	3.36		45.61	35.70	3.01		45.52	32.21	2.62		47.14	32.98	2.49
	57 (13.9)		33.46	33.46	4.43		36.07	36.07	4.05		38.20	38.20	3.69		40.20	40.20	3.35		42.00	42.00	3.01		40.56	38.89	2.60		42.13	39.75	2.45
80 (26.7)	72 (22.2)	1600	40.69	24.73	4.54	1600	45.26	26.35	4.14	1600	48.37	27.46	3.74	1600	51.31	28.53	3.35	1600	53.68	29.40	2.99	1200	53.59	27.40	2.63	1200	54.88	27.91	2.51
	67 (19.4)		37.21	32.41	4.49		41.12	33.99	4.11		44.04	35.16	3.73		46.80	36.27	3.36		49.19	37.26	3.01		49.06	33.40	2.63		50.59	34.07	2.50
	63 (17.2)		35.76	35.76	4.47		38.69	38.68	4.08		41.21	40.29	3.71		43.51	42.06	3.36		45.74	43.15	3.01		45.48	38.00	2.62		47.08	38.77	2.49
	57 (13.9)		35.67	35.67	4.47		38.60	38.60	4.08		40.84	40.84	3.71		42.92	42.92	3.36		44.74	44.74	3.01		42.32	42.32	2.61		43.62	43.62	2.46
<b>MEDIAN DEMAND</b>																													
75 (23.9)	72 (22.2)	1400	37.05	15.56	3.83	1350	40.73	16.80	3.45	1250	39.97	16.42	2.74	1150	38.66	15.84	2.11	1100	36.33	14.95	1.56	800	36.04	14.49	1.37	800	37.00	14.86	1.14
	67 (19.4)		33.63	22.43	3.79		36.90	23.42	3.43		36.35	22.68	2.74		35.35	21.74	2.14		33.69	20.82	1.61		33.46	18.91	1.41		34.62	19.42	1.21
	63 (17.2)		30.48	27.48	3.75		33.93	28.53	3.40		33.50	27.50	2.73		32.66	26.25	2.15		31.33	25.26	1.63		31.06	22.16	1.43		32.41	22.79	1.24
	57 (13.9)		30.08	30.08	3.74		32.08	32.08	3.38		31.39	31.39	2.73		30.34	30.34	2.15		29.23	29.23	1.65		27.60	26.79	1.45		28.91	27.50	1.27
80 (26.7)	72 (22.2)	1400	36.74	22.34	3.83	1350	40.52	23.39	3.45	1250	39.75	22.60	2.74	1150	38.39	21.57	2.11	1100	36.04	20.47	1.56	800	35.74	18.49	1.36	800	36.82	18.91	1.14
	67 (19.4)		33.08	28.97	3.79		36.79	29.95	3.43		36.25	28.81	2.74		35.24	27.43	2.13		33.55	26.29	1.61		33.35	22.93	1.41		34.44	23.41	1.20
	63 (17.2)		32.17	32.17	3.78		34.64	33.79	3.41		34.25	31.81	2.74		32.78	31.82	2.15		31.44	30.63	1.63		31.03	26.18	1.43		32.36	26.81	1.24
	57 (13.9)		32.11	32.11	3.77		34.32	34.32	3.41		33.54	33.54	2.74		32.39	32.39	2.15		31.12	31.12	1.64		28.98	28.98	1.44		30.05	30.05	1.26
<b>MINIMUM DEMAND</b>																													
75 (23.9)	72 (22.2)	1200	33.48	14.06	3.32	1100	36.31	14.92	2.95	900	31.54	12.94	2.00	700	24.65	10.16	1.17	600	17.52	7.45	0.61	600	17.88	7.57	0.48	600	17.73	7.52	0.35
	67 (19.4)		30.32	20.02	3.29		32.83	20.38	2.93		28.63	17.56	2.00		22.54	13.89	1.20		16.13	10.70	0.64		16.75	10.94	0.52		16.70	10.92	0.39
	63 (17.2)		27.98	24.66	3.26		30.15	24.61	2.91		26.31	21.07	2.00		20.69	16.67	1.22		14.96	13.20	0.66		15.70	13.52	0.54		16.09	13.68	0.43
	57 (13.9)		26.92	26.92	3.25		28.17	28.17	2.89		24.35	24.35	2.00		19.16	19.16	1.22		14.38	14.38	0.67		15.14	15.14	0.56		15.58	15.58	0.45
80 (26.7)	72 (22.2)	1200	33.22	19.98	3.31	1100	36.12	20.40	2.95	900	31.35	17.52	2.00	700	24.44	13.75	1.17	600	17.34	10.56	0.61	600	17.62	10.66	0.48	600	16.62	10.31	0.33
	67 (19.4)		30.21	25.88	3.29		32.72	25.81	2.93		28.55	22.08	2.00		22.47	17.47	1.20		16.07	13.80	0.64		16.70	14.07	0.52		16.51	13.99	0.39
	63 (17.2)		28.82	28.82	3.28		30.32	29.88	2.91		26.38	25.55	2.00		20.74	20.23	1.21		15.45	15.45	0.65		16.06	16.06	0.54		16.20	16.20	0.42
	57 (13.9)		28.77	28.77	3.28		30.12	30.12	2.91		26.03	26.03	2.00		20.52	20.52	1.22		15.42	15.42	0.65		16.03	16.03	0.54		16.22	16.22	0.42

See notes on page 22

Manufacturer reserves the right to change, at any time, specifications and designs without notice and without obligations.

# Detailed Cooling Capacities<sup>#</sup> - Cooling Efficiency Mode (cont.)

## 25VNA460/FE4ANB006 COOLING EFFICIENCY MODE CONDENSER ENTERING AIR TEMPERATURES °F (°C)

EDB °F (°C)	EVAPORATOR AIR EWB °F (°C)	125 (46.1)			115 (46.1)			105 (40.6)			95 (35)			85 (29.4)			75 (23.9)			65 (18.3)									
		ID SCFM	Capacity MBtuh†		Total Sys. KW**	ID SCFM	Capacity MBtuh		Total Sys. KW**	ID SCFM	Capacity MBtuh		Total Sys. KW**	ID SCFM	Capacity MBtuh		Total Sys. KW**	ID SCFM	Capacity MBtuh		Total Sys. KW**	ID SCFM	Capacity MBtuh		Total Sys. KW**				
			Total	Sens‡			Total	Sens‡			Total	Sens‡			Total	Sens‡			Total	Sens‡			Total	Sens‡		Total	Sens‡	Total	Sens‡
<b>MAXIMUM DEMAND</b>																													
75 (23.9)	72 (22.2)	2000	49.10	20.36	6.31	2000	55.86	22.73	5.77	1775	61.34	24.68	4.96	1625	64.21	25.67	4.33	1625	64.14	25.56	3.74	1625	66.95	26.62	3.30	1475	68.43	27.20	2.85
	67 (19.4)		45.18	30.47	6.30		51.03	32.75	5.75		56.04	33.98	4.94		58.65	34.26	4.32		58.63	33.79	3.73		61.17	34.86	3.30		62.46	34.75	2.83
	63 (17.2)		42.25	38.30	6.29		46.88	40.33	5.71		51.98	41.25	4.93		54.39	40.95	4.31		54.38	40.16	3.73		56.77	41.25	3.30		57.99	40.59	2.83
	57 (13.9)		41.18	41.18	6.28		44.74	44.74	5.69		47.71	47.71	4.89		48.81	48.81	4.27		49.30	46.32	3.69		51.71	46.69	3.27		51.23	48.67	2.80
80 (26.7)	72 (22.2)	2000	48.63	30.10	6.31	2000	55.53	32.51	5.77	1775	61.07	33.75	4.95	1625	63.98	34.05	4.33	1625	63.93	33.56	3.74	1625	66.73	34.64	3.30	1475	68.24	34.56	2.84
	67 (19.4)		44.95	40.04	6.30		50.84	42.43	5.75		55.86	42.99	4.94		58.50	42.58	4.32		58.49	41.71	3.73		61.02	42.78	3.30		62.34	41.99	2.83
	63 (17.2)		43.65	43.65	6.29		47.82	47.82	5.71		52.12	49.97	4.93		54.40	49.17	4.31		54.36	48.02	3.73		56.74	49.13	3.30		57.92	47.80	2.83
	57 (13.9)		43.60	43.60	6.29		47.66	47.66	5.71		50.76	50.76	4.90		51.86	51.86	4.28		51.37	51.37	3.70		53.19	53.19	3.27		53.18	53.18	2.80
<b>MEDIAN DEMAND</b>																													
75 (23.9)	72 (22.2)	1750	46.73	19.51	5.15	1750	52.78	21.64	4.65	1625	52.41	21.40	3.74	1400	49.60	20.21	2.83	1250	46.07	18.72	2.09	1250	48.05	19.44	1.79	1175	49.10	19.77	1.54
	67 (19.4)		43.12	28.95	5.14		48.28	30.96	4.64		47.95	30.11	3.74		45.47	27.81	2.84		42.34	25.63	2.11		44.26	26.41	1.82		45.37	26.43	1.56
	63 (17.2)		40.45	36.31	5.12		44.83	38.21	4.62		44.48	36.89	3.74		42.15	33.69	2.85		39.36	30.96	2.13		41.20	31.77	1.83		42.37	31.55	1.57
	57 (13.9)		39.36	39.36	5.12		42.78	42.78	4.61		42.01	42.01	3.73		39.28	39.28	2.85		36.43	36.43	2.14		37.88	37.88	1.85		38.98	37.18	1.58
80 (26.7)	72 (22.2)	1750	46.23	28.53	5.14	1750	52.42	30.71	4.65	1625	52.08	29.87	3.74	1400	49.31	27.54	2.83	1250	45.76	25.33	2.09	1250	47.72	26.05	1.79	1175	48.82	26.02	1.54
	67 (19.4)		42.87	37.85	5.13		48.09	39.96	4.64		47.77	38.54	3.74		45.30	35.12	2.84		42.19	32.20	2.11		44.09	32.98	1.82		45.23	32.63	1.56
	63 (17.2)		41.60	41.60	5.13		45.90	44.65	4.63		44.78	44.78	3.74		42.29	40.83	2.85		39.44	37.42	2.12		41.24	38.27	1.83		42.36	37.71	1.57
	57 (13.9)		41.55	41.55	5.13		45.49	45.49	4.63		44.69	44.69	3.74		41.74	41.74	2.85		38.71	38.71	2.13		40.18	40.18	1.84		40.68	40.68	1.57
<b>MINIMUM DEMAND</b>																													
75 (23.9)	72 (22.2)	1500	40.90	17.22	4.43	1500	46.18	19.07	3.99	1475	40.55	17.06	2.79	1175	31.40	13.47	1.68	875	20.67	9.14	0.90	875	21.76	9.50	0.71	875	22.25	9.70	0.60
	67 (19.4)		37.73	25.41	4.43		42.27	27.17	3.98		36.89	24.94	2.80		28.75	19.84	1.70		18.82	13.89	0.93		19.78	14.26	0.74		20.32	14.46	0.62
	63 (17.2)		35.56	31.87	4.44		39.52	33.58	3.99		34.71	31.24	2.82		27.01	24.88	1.72		18.09	16.31	0.94		18.72	18.05	0.77		19.24	18.29	0.64
	57 (13.9)		34.35	34.35	4.42		37.38	37.38	3.97		33.35	33.35	2.81		26.03	26.03	1.72		17.37	17.37	0.94		18.32	18.32	0.77		18.86	18.86	0.65
80 (26.7)	72 (22.2)	1500	40.43	25.04	4.42	1500	45.84	26.95	3.99	1475	40.17	24.80	2.78	1175	31.01	19.64	1.67	875	20.46	13.82	0.90	875	21.51	14.18	0.71	875	22.02	14.36	0.59
	67 (19.4)		37.51	33.14	4.43		42.10	34.98	3.98		36.78	32.57	2.80		28.68	25.98	1.70		18.82	18.46	0.92		19.75	18.84	0.74		20.28	19.07	0.62
	63 (17.2)		36.46	36.46	4.44		40.09	40.09	3.99		35.89	35.89	2.81		28.15	28.15	1.71		18.90	18.90	0.93		19.75	19.75	0.75		20.18	20.18	0.63
	57 (13.9)		36.27	36.27	4.42		39.74	39.74	3.98		35.53	35.53	2.80		27.78	27.78	1.71		18.59	18.59	0.93		19.38	19.38	0.74		19.86	19.86	0.62

† Total and sensible capacities are net capacities. Blower motor heat has been subtracted.

‡ Sensible capacities shown are based on 80°F (27°C) entering air at the indoor coil. For sensible capacities at other than 80°F (27°C), deduct 835 Btuh (245 kW) per 1000 CFM (480 L/S) of indoor coil air for each degree below 80°F (27°C), or add 835 Btuh (245 kW) per 1000 CFM (480 L/S) of indoor coil air per degree above 80°F (27°C).

\*\* System kw is total of indoor and outdoor unit kilowatts.

# Detailed cooling capacities are based on indoor and outdoor unit at the same elevation per AHRI standard 210/240-08. If additional tubing length and/or indoor unit is located above outdoor unit, a slight variation in capacity may occur.

NOTE: When the required data falls between the published data, interpolation may be performed. Extrapolation is not an acceptable practice.

EWB — Entering Wet Bulb

Manufacturer reserves the right to change, at any time, specifications and designs without notice and without obligations.

# Heat Pump Heating Performance – comfort mode

25VNA424/FE4ANB002 Heating Comfort Mode Condenser Entering Air Temperature °F (°C)																																
INDOOR AIR		-3 (-19.4)				7 (-13.9)			17 (-8.3)			27 (-2.8)			37 (2.7)			47 (8.3)			57 (13.9)			67 (19.4)								
EDB	ID SCFM	Capacity MBtuh		Total Sys. KW†	ID SCFM	Capacity MBtuh		Total Sys. KW†	ID SCFM	Capacity MBtuh		Total Sys. KW†	ID SCFM	Capacity MBtuh		Total Sys. KW†	ID SCFM	Capacity MBtuh		Total Sys. KW†	ID SCFM	Capacity MBtuh		Total Sys. KW†	ID SCFM	Capacity MBtuh		Total Sys. KW†				
		Total	Integ‡			Total	Integ‡			Total	Integ‡			Total	Integ‡			Total	Integ‡			Total	Integ‡			Total	Integ‡		Total	Integ‡	Total	Integ‡
<b>MAXIMUM DEMAND</b>																																
65 (18.3)	500	15.21	13.99	2.15	500	19.41	17.84	2.51	500	23.84	21.74	2.78	500	28.34	25.17	3.13	500	32.43	29.51	3.48	500	36.29	36.29	3.90	500	21.93	21.93	1.69	500	24.43	24.43	1.80
70 (21.1)		14.80	13.62	2.26		19.06	17.51	2.59		23.47	21.40	2.84		27.82	24.71	3.16		31.84	28.98	3.52		35.60	35.60	3.95		21.62	21.62	1.76		24.15	24.15	1.88
75 (23.9)		14.47	13.31	2.36		18.70	17.19	2.66		23.10	21.06	2.88		27.32	24.26	3.20		31.24	28.43	3.56		34.88	34.88	4.01		21.25	21.25	1.83		23.68	23.68	1.94
<b>MEDIAN DEMAND</b>																																
65 (18.3)	400	12.27	11.29	1.64	400	16.29	14.97	1.95	400	20.53	18.71	2.17	400	24.58	21.83	2.36	400	25.63	23.32	2.26	400	26.55	26.55	2.15	400	18.57	18.57	1.17	400	19.15	19.15	1.09
70 (21.1)		11.84	10.89	1.68		15.98	14.69	2.01		20.18	18.39	2.23		24.06	21.37	2.42		25.21	22.95	2.33		26.11	26.11	2.23		18.28	18.28	1.23		18.95	18.95	1.16
75 (23.9)		11.69	10.75	1.76		15.64	14.38	2.05		19.81	18.06	2.29		23.58	20.94	2.48		24.77	22.54	2.40		25.60	25.60	2.29		18.00	18.00	1.29		18.72	18.72	1.22
<b>MINIMUM DEMAND</b>																																
65 (18.3)	300	6.24	5.74	0.89	300	8.69	7.98	0.98	300	10.90	9.94	1.06	300	12.81	11.38	1.14	300	14.10	12.83	1.17	300	12.00	12.00	0.85	300	10.84	10.84	0.65	300	9.00	9.00	0.44
70 (21.1)		6.11	5.62	0.91		8.53	7.84	1.01		10.70	9.76	1.09		12.57	11.16	1.18		13.83	12.59	1.22		11.78	11.78	0.90		10.64	10.64	0.69		8.86	8.86	0.48
75 (23.9)		5.98	5.50	0.94		8.37	7.69	1.04		10.49	9.56	1.13		12.32	10.94	1.22		13.55	12.33	1.26		11.55	11.55	0.94		10.44	10.44	0.73		8.79	8.79	0.52

See notes on page 30

23 Manufacturer reserves the right to change, at any time, specifications and designs without notice and without obligations.

### Heat Pump Heating Performance – comfort mode (cont.)

INDOOR AIR		25VNA436/FE4ANB005 Expanded Ratings Heating Comfort Mode Condenser Entering Air Temperatures °F (°C)																														
		-3 (-19.4)			7 (-13.9)			17 (-8.3)			27 (-2.8)			37 (2.7)			47 (8.3)			57 (13.9)			67 (19.4)									
EDB	ID SCFM	Capacity MBtuh		Total Sys. KW†	ID SCFM	Capacity MBtuh		Total Sys. KW†	ID SCFM	Capacity MBtuh		Total Sys. KW†	ID SCFM	Capacity MBtuh		Total Sys. KW†	ID SCFM	Capacity MBtuh		Total Sys. KW†	ID SCFM	Capacity MBtuh		Total Sys. KW†	ID SCFM	Capacity MBtuh		Total Sys. KW†				
		Total	Integ‡			Total	Integ‡			Total	Integ‡			Total	Integ‡			Total	Integ‡			Total	Integ‡			Total	Integ‡		Total	Integ‡	Total	Integ‡
<b>MAXIMUM DEMAND</b>																																
65 (18.3)	750	22.58	20.99	3.43	750	27.98	25.71	3.63	970	33.38	30.43	3.83	1120	39.30	34.91	4.08	1200	45.23	41.15	4.34	1260	44.51	44.51	3.69	1300	41.82	41.82	2.91	1300	40.28	40.28	2.40
70 (21.1)		22.28	20.71	3.54		27.63	25.39	3.76		32.97	30.06	3.97		38.87	34.52	4.23		45.26	41.18	4.53		44.22	44.22	3.83		41.25	41.25	3.02		39.66	39.66	2.50
75 (23.9)		21.98	20.43	3.65		27.27	25.06	3.88		32.56	29.68	4.11		38.20	33.93	4.37		44.53	40.53	4.68		43.55	43.55	3.97		40.75	40.75	3.14		39.05	39.05	2.60
<b>MEDIAN DEMAND</b>																																
65 (18.3)	525	16.19	15.06	2.43	525	19.85	18.25	2.54	660	24.05	21.92	2.69	730	25.70	22.83	2.51	750	28.78	26.19	2.55	780	27.91	27.91	2.11	810	26.92	26.92	1.73	810	27.27	27.27	1.50
70 (21.1)		15.91	14.79	2.50		19.55	17.96	2.61		23.71	21.62	2.78		25.36	22.53	2.61		28.57	25.99	2.65		27.58	27.58	2.20		26.50	26.50	1.81		26.46	26.46	1.56
75 (23.9)		15.64	14.54	2.56		19.25	17.69	2.69		23.38	21.32	2.87		24.96	22.17	2.70		28.14	25.61	2.75		27.18	27.18	2.29		26.13	26.13	1.89		26.16	26.16	1.64
<b>MINIMUM DEMAND</b>																																
65 (18.3)	300	10.00	9.28	1.59	300	14.23	13.08	1.41	350	15.78	14.39	1.33	350	14.65	13.01	1.05	300	14.49	13.18	0.95	300	13.20	13.20	0.76	300	14.49	14.49	0.73	300	15.28	15.28	0.67
70 (21.1)		9.77	9.07	1.62		13.93	12.80	1.45		15.48	14.11	1.37		14.38	12.77	1.10		14.23	12.95	1.00		12.92	12.92	0.80		10.52	10.52	0.73		11.00	11.00	0.71
75 (23.9)		9.52	8.84	1.66		13.62	12.52	1.49		15.18	13.84	1.42		14.07	12.50	1.14		13.95	12.69	1.04		12.70	12.70	0.84		14.01	14.01	0.82		14.83	14.83	0.76

See notes on page 30

Manufacturer reserves the right to change, at any time, specifications and designs without notice and without obligations.

### Heat Pump Heating Performance – comfort mode (cont.)

INDOOR AIR		25VNA448/FE4ANB006 Expanded Ratings Heating Comfort Mode Condenser Entering Air Temperatures °F (°C)																														
		-3 (-19.4)			7 (-13.9)			17 (-8.3)			27 (-2.8)			37 (2.7)			47 (8.3)			57 (13.9)			67 (19.4)									
EDB	ID SCFM	Capacity MBtuh		Total Sys. KW†	ID SCFM	Capacity MBtuh		Total Sys. KW†	ID SCFM	Capacity MBtuh		Total Sys. KW†	ID SCFM	Capacity MBtuh		Total Sys. KW†	ID SCFM	Capacity MBtuh		Total Sys. KW†	ID SCFM	Capacity MBtuh		Total Sys. KW†	ID SCFM	Capacity MBtuh		Total Sys. KW†				
		Total	Integ‡			Total	Integ‡			Total	Integ‡			Total	Integ‡			Total	Integ‡			Total	Integ‡			Total	Integ‡		Total	Integ‡	Total	Integ‡
<b>MAXIMUM DEMAND</b>																																
65 (18.3)	500	17.26	15.88	2.61	900	34.21	31.44	4.40	1250	41.09	37.46	4.58	1450	47.73	42.39	4.75	1550	53.49	48.67	4.78	1450	46.85	46.85	3.34	1400	54.13	54.13	3.51	1400	61.67	61.67	3.66
70 (21.1)		16.90	15.55	2.68		33.70	30.97	4.51		40.49	36.92	4.71		47.04	41.78	4.89		52.73	47.98	4.93		46.13	46.13	3.48		53.33	53.33	3.66		60.86	60.86	3.83
75 (23.9)		16.47	15.16	2.75		33.18	30.49	4.63		39.89	36.37	4.84		46.34	41.16	5.03		51.95	47.28	5.09		45.40	45.40	3.61		52.50	52.50	3.81		60.02	60.02	4.00
<b>MEDIAN DEMAND</b>																																
65 (18.3)	500	15.11	13.90	2.31	700	25.49	23.42	3.27	850	30.95	28.22	3.47	1000	34.24	30.41	3.30	1000	35.26	32.08	2.95	1000	33.89	33.89	2.38	950	35.66	35.66	2.18	950	39.70	39.70	2.20
70 (21.1)		14.80	13.62	2.46		25.08	23.05	3.44		30.46	27.77	3.65		33.70	29.93	3.53		34.69	31.56	3.20		33.33	33.33	2.65		35.16	35.16	2.42		39.22	39.22	2.41
75 (23.9)		14.41	13.26	2.53		24.66	22.66	3.54		29.97	27.33	3.76		33.15	29.44	3.64		34.11	31.04	3.31		32.76	32.76	2.76		34.61	34.61	2.53		38.73	38.73	2.54
<b>MINIMUM DEMAND</b>																																
65 (18.3)	500	13.11	12.06	2.04	500	17.00	15.62	2.26	650	21.11	19.25	2.36	620	21.11	18.75	2.04	500	18.14	16.50	1.51	500	17.92	17.92	1.27	500	18.83	18.83	1.16	500	19.53	19.53	1.10
70 (21.1)		12.83	11.81	2.11		16.63	15.28	2.33		20.72	18.89	2.44		20.73	18.41	2.12		17.79	16.19	1.57		17.59	17.59	1.34		18.53	18.53	1.23		19.16	19.16	1.17
75 (23.9)		12.51	11.51	2.18		16.29	14.97	2.40		20.32	18.53	2.52		20.33	18.06	2.20		17.44	15.87	1.64		17.25	17.25	1.41		18.24	18.24	1.30		18.77	18.77	1.23

See notes on page 30

25 Manufacturer reserves the right to change, at any time, specifications and designs without notice and without obligations.

### Heat Pump Heating Performance – comfort mode (cont.)

INDOOR AIR		25VNA460/FE4ANB006 Expanded Ratings Heating Comfort Mode Condenser Entering Air Temperatures °F (°C)																														
		-3 (-19.4)			7 (-13.9)			17 (-8.3)			27 (-2.8)			37 (2.7)			47 (8.3)			57 (13.9)			67 (19.4)									
EDB	ID SCFM	Capacity MBtuh		Total Sys. KW†	ID SCFM	Capacity MBtuh		Total Sys. KW†	ID SCFM	Capacity MBtuh		Total Sys. KW†	ID SCFM	Capacity MBtuh		Total Sys. KW†	ID SCFM	Capacity MBtuh		Total Sys. KW†	ID SCFM	Capacity MBtuh		Total Sys. KW†	ID SCFM	Capacity MBtuh		Total Sys. KW†				
		Total	Integ‡			Total	Integ‡			Total	Integ‡			Total	Integ‡			Total	Integ‡			Total	Integ‡			Total	Integ‡		Total	Integ‡		
<b>MAXIMUM DEMAND</b>																																
65 (18.3)	2000	19.54	17.98	2.91	2000	23.37	21.48	2.93	1150	40.34	36.78	3.84	1450	44.07	39.14	4.35	1750	52.27	47.57	4.63	1900	66.10	66.10	5.48	2000	61.59	61.59	4.25	2000	54.08	54.08	3.16
70 (21.1)		19.00	17.48	3.06		22.99	21.12	3.07		39.53	36.05	4.01		43.64	38.76	4.56		51.54	46.90	4.86		65.80	65.80	5.75		60.91	60.91	4.47		54.30	54.30	3.35
75 (23.9)		19.08	17.56	3.19		22.73	20.89	3.23		39.13	35.68	4.20		42.96	38.16	4.76		51.02	46.43	5.09		64.11	64.11	6.01		59.58	59.58	4.70		52.56	52.56	3.53
<b>MEDIAN DEMAND</b>																																
65 (18.3)	1625	15.79	14.53	2.30	1625	18.90	17.37	2.30	825	25.46	23.21	2.77	975	29.94	26.59	2.80	1125	34.74	31.62	2.82	1200	41.43	41.43	3.02	1250	41.61	41.61	2.57	1250	36.31	36.31	1.92
70 (21.1)		15.56	14.31	2.45		18.74	17.22	2.45		25.01	22.81	2.91		29.53	26.23	2.96		34.08	31.01	2.97		40.26	40.26	3.19		40.39	40.39	2.72		35.32	35.32	2.05
75 (23.9)		15.32	14.10	2.57		18.53	17.03	2.57		24.73	22.55	3.07		29.21	25.94	3.12		33.78	30.74	3.15		40.08	40.08	3.37		40.23	40.23	2.89		35.36	35.36	2.19
<b>MINIMUM DEMAND</b>																																
65 (18.3)	1250	11.65	10.71	1.71	1250	14.28	13.12	1.71	500	14.96	13.64	1.71	500	14.98	13.30	1.46	500	14.99	13.64	1.29	500	14.60	14.60	1.10	500	20.89	20.89	1.65	500	17.35	17.35	1.20
70 (21.1)		11.38	10.47	1.81		14.08	12.93	1.83		14.69	13.39	1.82		14.70	13.05	1.55		14.61	13.30	1.38		14.33	14.33	1.18		20.54	20.54	1.75		17.54	17.54	1.30
75 (23.9)		11.33	10.43	1.93		13.88	12.76	1.95		14.76	13.45	1.94		14.77	13.12	1.67		14.74	13.41	1.48		14.48	14.48	1.29		20.20	20.20	1.84		17.08	17.08	1.38

See notes on page 30

26 Manufacturer reserves the right to change, at any time, specifications and designs without notice and without obligations.

# Heat Pump Heating Performance – Efficiency Mode

INDOOR AIR		25VNA424/FE4ANB002 Expanded Ratings Heating Efficiency Mode Condenser Entering Air Temperatures °F (°C)																														
		-3 (-19.4)			7 (-13.9)			17 (-8.3)			27 (-2.8)			37 (2.7)			47 (8.3)			57 (13.9)			67 (19.4)									
EDB	ID SCFM	Capacity MBtuh		Total Sys. KW†	ID SCFM	Capacity MBtuh		Total Sys. KW†	ID SCFM	Capacity MBtuh		Total Sys. KW†	ID SCFM	Capacity MBtuh		Total Sys. KW†	ID SCFM	Capacity MBtuh		Total Sys. KW†	ID SCFM	Capacity MBtuh		Total Sys. KW†	ID SCFM	Capacity MBtuh		Total Sys. KW†				
		Total	Integ‡			Total	Integ‡			Total	Integ‡			Total	Integ‡			Total	Integ‡			Total	Integ‡			Total	Integ‡		Total	Integ‡		
<b>MAXIMUM DEMAND</b>																																
65 (18.3)	1000	14.59	13.42	1.88	1000	19.23	17.67	2.32	1000	24.77	22.58	2.56	1000	29.28	26.01	2.89	940	35.45	32.26	3.23	850	39.04	39.04	3.57	850	23.16	23.16	1.51	850	26.17	26.17	1.55
70 (21.1)		14.02	12.89	2.06		18.92	17.39	2.47		24.40	22.25	2.69		28.95	25.71	2.99		34.96	31.81	3.32		38.50	38.50	3.66		22.81	22.81	1.59		25.83	25.83	1.64
75 (23.9)		13.25	12.19	2.20		18.39	16.90	2.58		24.01	21.89	2.80		28.30	25.13	3.07		32.91	29.95	3.37		37.93	37.93	3.75		22.44	22.44	1.66		25.47	25.47	1.72
<b>MEDIAN DEMAND</b>																																
65 (18.3)	890	11.71	10.77	1.59	890	14.12	12.98	1.67	890	18.84	17.18	1.81	890	20.33	18.06	1.78	845	20.62	18.77	1.48	775	23.95	23.95	1.53	775	17.02	17.02	0.94	775	20.12	20.12	0.94
70 (21.1)		11.03	10.15	1.59		14.26	13.10	1.71		18.37	16.75	1.85		20.87	18.54	1.86		19.89	18.10	1.54		23.60	23.60	1.60		16.67	16.67	0.99		19.75	19.75	1.00
75 (23.9)		10.79	9.93	1.61		13.95	12.82	1.74		18.01	16.42	1.90		20.46	18.18	1.91		19.90	18.10	1.60		23.22	23.22	1.67		16.33	16.33	1.05		19.36	19.36	1.07
<b>MINIMUM DEMAND</b>																																
65 (18.3)	650	5.65	5.20	0.87	650	7.99	7.35	0.92	650	10.32	9.41	0.96	650	10.71	9.51	0.84	650	3.60	3.28	0.34	650	2.68	2.68	0.38	650	4.79	4.79	0.34	650	7.08	7.08	0.29
70 (21.1)		5.61	5.16	0.89		7.93	7.28	0.95		10.12	9.23	0.99		10.50	9.32	0.88		3.47	3.16	0.36		1.54	1.54	0.38		4.66	4.66	0.36		7.02	7.02	0.32
75 (23.9)		5.43	5.00	0.91		7.72	7.09	0.98		9.90	9.03	1.03		10.27	9.12	0.92		3.35	3.05	0.38		1.74	1.74	0.39		4.50	4.50	0.38		6.90	6.90	0.35

See notes on page 30

Manufacturer reserves the right to change, at any time, specifications and designs without notice and without obligations.

### Heat Pump Heating Performance – Efficiency Mode (cont.)

INDOOR AIR		25VNA436/FE4ANB005 Expanded Ratings Heating EFFICIENCY MODE Condenser Entering Air Temperatures °F (°C)																														
		-3 (-19.4)			7 (-13.9)			17 (-8.3)			27 (-2.8)			37 (2.7)			47 (8.3)			57 (13.9)			67 (19.4)									
EDB	ID SCFM	Capacity		Total Sys. KW†	ID SCFM	Capacity		Total Sys. KW†	ID SCFM	Capacity		Total Sys. KW†	ID SCFM	Capacity		Total Sys. KW†	ID SCFM	Capacity		Total Sys. KW†	ID SCFM	Capacity		Total Sys. KW†	ID SCFM	Capacity		Total Sys. KW†				
		Total	Integ‡			Total	Integ‡			Total	Integ‡			Total	Integ‡			Total	Integ‡			Total	Integ‡			Total	Integ‡		Total	Integ‡	Total	Integ‡
<b>MAXIMUM DEMAND</b>																																
65 (18.3)	1500	23.57	21.91	3.27	1500	28.80	26.46	3.51	1500	34.02	31.02	3.75	1500	39.89	35.43	4.00	1500	45.80	41.67	4.26	1500	35.67	35.67	2.66	1500	36.87	36.87	2.41	1500	40.90	40.90	2.41
70 (21.1)		23.30	21.65	3.42		28.46	26.15	3.66		33.62	30.65	3.90		39.37	34.97	4.16		45.80	41.68	4.44		35.20	35.20	2.77		36.33	36.33	2.51		40.26	40.26	2.51
75 (23.9)		23.02	21.39	3.55		28.11	25.83	3.80		33.20	30.27	4.05		38.93	34.58	4.31		44.75	40.72	4.58		34.70	34.70	2.87		35.78	35.78	2.60		39.59	39.59	2.61
<b>MEDIAN DEMAND</b>																																
65 (18.3)	1100	16.30	15.15	2.33	1100	20.26	18.62	2.46	1100	24.21	22.08	2.59	1100	28.51	25.32	2.72	1100	32.31	29.40	2.77	1100	22.02	22.02	1.53	1100	23.27	23.27	1.41	1100	25.75	25.75	1.40
70 (21.1)		16.00	14.88	2.40		19.93	18.32	2.54		23.86	21.76	2.68		28.12	24.98	2.82		32.04	29.15	2.88		21.69	21.69	1.60		22.90	22.90	1.47		25.83	25.83	1.46
75 (23.9)		15.71	14.60	2.47		19.61	18.02	2.62		23.51	21.43	2.77		27.75	24.64	2.92		31.51	28.67	2.99		21.34	21.34	1.67		22.55	22.55	1.54		25.39	25.39	1.54
<b>MINIMUM DEMAND</b>																																
65 (18.3)	650	10.83	10.07	1.13	650	13.70	12.59	1.19	650	16.57	15.11	1.24	650	19.62	17.43	1.28	700	19.25	17.52	1.49	650	9.69	9.69	0.50	650	10.75	10.75	0.50	650	12.15	12.15	0.44
70 (21.1)		10.50	9.77	1.16		13.38	12.30	1.22		16.26	14.83	1.28		19.35	17.18	1.33		18.94	17.24	1.56		9.44	9.44	0.54		10.92	10.92	0.53		12.28	12.28	0.48
75 (23.9)		10.20	9.49	1.19		13.07	12.01	1.26		15.94	14.54	1.33		19.04	16.91	1.39		18.64	16.96	1.63		9.18	9.18	0.57		10.70	10.70	0.57		12.30	12.30	0.52

See notes on page 30

Manufacturer reserves the right to change, at any time, specifications and designs without notice and without obligations.

### Heat Pump Heating Performance – Efficiency Mode (cont.)

INDOOR AIR		25VNA448/FE4ANB006 Expanded Ratings Heating EFFICIENCY MODE Condenser Entering Air Temperatures °F (°C)																														
		-3 (-19.4)			7 (-13.9)			17 (-8.3)			27 (-2.8)			37 (2.7)			47 (8.3)			57 (13.9)			67 (19.4)									
EDB	ID SCFM	Capacity		Total Sys. KW†	ID SCFM	Capacity		Total Sys. KW†	ID SCFM	Capacity		Total Sys. KW†	ID SCFM	Capacity		Total Sys. KW†	ID SCFM	Capacity		Total Sys. KW†	ID SCFM	Capacity		Total Sys. KW†	ID SCFM	Capacity		Total Sys. KW†				
		Total	Integ‡			Total	Integ‡			Total	Integ‡			Total	Integ‡			Total	Integ‡			Total	Integ‡			Total	Integ‡		Total	Integ‡	Total	Integ‡
<b>MAXIMUM DEMAND</b>																																
65 (18.3)	1600	18.44	16.97	2.67	1600	34.88	32.05	4.35	1600	41.61	37.94	4.62	1600	48.05	42.67	4.79	1600	55.61	50.61	5.04	1400	46.73	46.73	3.34	1400	53.76	53.76	3.49	1400	60.52	60.52	3.62
70 (21.1)		18.15	16.70	2.75		34.38	31.59	4.46		41.03	37.41	4.75		47.36	42.07	4.93		54.83	49.90	5.20		46.01	46.01	3.47		53.04	53.04	3.65		59.83	59.83	3.80
75 (23.9)		17.64	16.23	2.81		33.87	31.12	4.58		40.42	36.86	4.88		46.66	41.44	5.07		54.02	49.16	5.35		45.27	45.27	3.61		52.27	52.27	3.80		59.06	59.06	3.97
<b>MEDIAN DEMAND</b>																																
65 (18.3)	1250	15.97	14.70	2.29	1250	25.81	23.71	3.16	1250	31.17	28.42	3.37	1200	32.09	28.50	2.96	1100	32.75	29.81	2.63	1100	28.78	28.78	1.87	1100	34.26	34.26	1.96	1100	38.91	38.91	2.01
70 (21.1)		15.67	14.42	2.44		25.41	23.35	3.33		30.70	27.99	3.55		31.60	28.07	3.19		32.21	29.31	2.87		29.00	29.00	2.12		33.74	33.74	2.19		38.45	38.45	2.22
75 (23.9)		15.28	14.06	2.51		25.00	22.97	3.42		30.21	27.55	3.66		31.07	27.59	3.31		31.65	28.81	2.98		27.76	27.76	2.22		33.09	33.09	2.30		37.95	37.95	2.35
<b>MINIMUM DEMAND</b>																																
65 (18.3)	900	12.91	11.88	1.95	900	17.08	15.69	2.13	900	21.17	19.30	2.26	800	17.15	15.23	1.51	600	9.52	8.66	0.73	600	11.85	11.85	0.71	600	14.00	14.00	0.76	600	16.27	16.27	0.81
70 (21.1)		12.55	11.55	2.01		16.66	15.31	2.20		20.79	18.95	2.35		16.80	14.92	1.58		9.46	8.61	0.78		11.58	11.58	0.76		13.66	13.66	0.81		15.81	15.81	0.87
75 (23.9)		12.12	11.15	2.07		16.27	14.95	2.28		20.39	18.59	2.44		16.43	14.59	1.66		8.97	8.16	0.82		11.30	11.30	0.81		13.49	13.49	0.86		15.54	15.54	0.93

See notes on page 30

Manufacturer reserves the right to change, at any time, specifications and designs without notice and without obligations.

### Heat Pump Heating Performance – Efficiency Mode (cont.)

INDOOR AIR		25VNA460/FE4ANB006 Expanded Ratings Heating EFFICIENCY MODE Condenser Entering Air Temperatures °F (°C)																														
		-3 (-19.4)			7 (-13.9)			17 (-8.3)			27 (-2.8)			37 (2.7)			47 (8.3)			57 (13.9)			67 (19.4)									
EDB	ID SCFM	Capacity MBtuh		Total Sys. KW†	ID SCFM	Capacity MBtuh		Total Sys. KW†	ID SCFM	Capacity MBtuh		Total Sys. KW†	ID SCFM	Capacity MBtuh		Total Sys. KW†	ID SCFM	Capacity MBtuh		Total Sys. KW†	ID SCFM	Capacity MBtuh		Total Sys. KW†	ID SCFM	Capacity MBtuh		Total Sys. KW†				
		Total	Integ‡			Total	Integ‡			Total	Integ‡			Total	Integ‡			Total	Integ‡			Total	Integ‡			Total	Integ‡		Total	Integ‡	Total	Integ‡
<b>MAXIMUM DEMAND</b>																																
65 (18.3)	2000	26.77	24.63	3.84	2000	37.31	34.29	4.74	2000	50.18	45.75	4.92	2000	50.98	45.27	5.15	2000	47.73	43.44	5.11	2000	66.96	66.96	5.49	2000	64.95	64.95	4.54	2000	54.72	54.72	3.16
70 (21.1)		25.80	23.74	4.01		36.62	33.65	4.93		49.26	44.91	5.13		50.04	44.44	5.36		58.22	52.98	5.58		66.31	66.31	5.76		64.24	64.24	4.76		54.18	54.18	3.35
75 (23.9)		25.92	23.85	4.14		36.31	33.37	5.14		48.82	44.52	5.35		49.57	44.02	5.60		56.49	51.41	5.79		64.28	64.28	5.99		62.17	62.17	4.97		52.36	52.36	3.52
<b>MEDIAN DEMAND</b>																																
65 (18.3)	1625	19.78	18.20	2.89	1625	25.86	23.77	3.14	1635	30.34	27.66	3.22	1725	35.67	31.68	3.34	1765	41.36	37.64	3.43	1425	39.95	39.95	2.83	1425	38.21	38.21	2.53	1425	36.08	36.08	1.96
70 (21.1)		19.60	18.03	3.04		25.70	23.61	3.31		30.05	27.40	3.39		35.31	31.36	3.52		40.92	37.24	3.62		39.50	39.50	3.01		37.64	37.64	2.68		35.56	35.56	2.09
75 (23.9)		19.77	18.19	3.16		25.43	23.37	3.47		29.75	27.12	3.57		34.94	31.03	3.71		40.47	36.83	3.81		39.05	39.05	3.18		37.07	37.07	2.84		34.98	34.98	2.23
<b>MINIMUM DEMAND</b>																																
65 (18.3)	1250	13.02	11.98	1.97	1250	13.36	12.28	1.71	1270	13.87	12.65	1.69	1450	13.18	11.70	1.73	1525	11.12	10.12	1.74	850	5.07	5.07	0.82	850	5.28	5.28	0.95	850	4.33	4.33	0.97
70 (21.1)		12.84	11.81	2.09		13.24	12.17	1.82		16.43	14.98	1.85		19.83	17.62	1.86		23.18	21.09	1.88		12.71	12.71	0.95		13.94	13.94	1.08		16.51	16.51	1.11
75 (23.9)		12.73	11.71	2.21		13.24	12.16	1.94		16.19	14.76	1.97		19.59	17.40	1.98		22.89	20.83	2.01		12.47	12.47	1.03		13.66	13.66	1.16		16.19	16.19	1.20

**NOTES:**  
 † The kW values include the compressor, outdoor fan motor, and indoor blower motor. The kW from supplement heaters should be added to these values to obtain Total Sys. kilowatts.  
 ‡ The Btuh heating capacity values shown are net integrated values from which the defrost effect has been subtracted. The Btuh heating from supplement heaters should be added to those values to obtain Total Sys. capacity.  
**NOTE:** When the required data falls between the published data, interpolation may be performed. Extrapolation is not an acceptable practice.  
 EDB — Entering Dry Bulb

Manufacturer reserves the right to change, at any time, specifications and designs without notice and without obligations.

## Guide specifications

### General

## AIR-COOLED, SPLIT-SYSTEM HEAT PUMP

25VNA4

2 TO 5 NOMINAL TONS

### System Description

Outdoor-mounted, air-cooled, split-system heat pump unit suitable for ground or rooftop installation. Unit consists of a hermetic compressor, an air-cooled coil, forward-swept blade propeller-type condenser fan, and a control box. Unit will discharge supply air upward as shown on contract drawings. Unit will be used in a refrigeration circuit to match up to a packaged fan coil or coil unit.

### Quality Assurance

- Unit will be rated in accordance with the latest edition of AHRI Standard 240.
- Unit will be certified for capacity and efficiency, and listed in the latest AHRI directory.
- Unit construction will comply with latest edition of ASHRAE and with NEC.
- Unit will be constructed in accordance with UL standards and will carry the UL label of approval. Unit will have C-UL approval.
- Unit cabinet will be capable of withstanding Federal Test Method Standard No. 141 (Method 6061) 500-hr salt spray test.
- Air-cooled condenser coils are pressure tested and the outdoor units are leak tested.
- Unit constructed in ISO9001 approved facility.

### Delivery, Storage, and Handling

- Unit will be shipped as single package only and is stored and handled per unit manufacturer's recommendations.

### Warranty (for inclusion by specifying engineer)

- U.S. and Canada only.

## PRODUCTS

### Equipment

- Factory-assembled, single-piece, air-cooled heat pump unit. Contained within the unit enclosure is all factory wiring, piping, controls, compressor, refrigerant charge Puron® (R-410A) refrigerant, and special features required prior to field start-up.

### Unit Cabinet

- Unit cabinet will be constructed of galvanized steel, bonderized, and coated with a powder coat paint.

### Fans

- Condenser fan will be direct-drive propeller type, forward swept blade, discharging air upward.
- Condenser fan motors will be totally enclosed, 1-phase type with class B insulation and permanently lubricated.
- Shafts will be corrosion resistant.
- Fan blades will be statically and dynamically balanced.
- Condenser fan openings will be equipped with coated steel wire safety guards.

### Compressor

- Compressor will be hermetically sealed.
- Compressor will be mounted on rubber vibration isolators.
- Compressor will be covered with a sound absorbing blanket.

### Condenser Coil

- Condenser coil will be air cooled.
- Coil will be constructed of aluminum fins mechanically bonded to copper tubes which are then cleaned, dehydrated, and sealed.

### Refrigeration Components

- Refrigeration circuit components will include liquid-line front-seating shutoff valve with sweat connections, vapor-line front-seating shutoff valve with sweat connections, system charge of Puron® (R-410A) refrigerant, PVE compressor oil, accumulator, electronic expansion valve, and reversing valve. Some models will be equipped with a brazed plate heat exchanger and vapor injection EXV
- Unit will be equipped with high-pressure switch, suction pressure transducer, discharge pressure transducer and filter drier for Puron® refrigerant.

### Operating Characteristics

- The capacity of the unit will meet or exceed \_\_\_\_\_ Btuh at a suction temperature of \_\_\_\_\_ °F (°C). The power consumption at full load will not exceed \_\_\_\_\_ kW.
- Combination of the unit and the evaporator or fan coil unit will have a total net cooling capacity of \_\_\_\_\_ Btuh or greater at conditions of \_\_\_\_\_ CFM entering air temperature at the evaporator at \_\_\_\_\_ °F (°C) wet bulb and \_\_\_\_\_ °F (°C) dry bulb, and air entering the unit at \_\_\_\_\_ °F (°C).
- The system will have a SEER of \_\_\_\_\_ Btuh/watt or greater at DOE conditions.

### Electrical Requirements

- Nominal unit electrical characteristics will be \_\_\_\_\_ v, single phase, 60 hz. The unit will be capable of satisfactory operation within voltage limits of \_\_\_\_\_ v to \_\_\_\_\_ v.
- Unit electrical power will be single point connection.
- Control circuit will be 24v.

### Special Features

- Refer to section of this literature identifying accessories and descriptions for specific features and available enhancements.
- Infinity control with appropriate software version is required for full featured operation.

## System Design Summary

1. Intended for outdoor installation with free air inlet and outlet. Outdoor fan external static pressure available is less than 0.01-in. wc.
2. This product is qualified for low ambient cooling operation (below 55°F / 12.8°C) with an Infinity User Interface **ONLY**.
3. The maximum outdoor operating ambient in cooling mode is 125°F (51.67°C).
4. Minimum outdoor operating air temperature for heating mode is -15°F (-26.1°C).
5. Maximum outdoor operating air temperature for heating mode is 75°F (23.9°C).
6. For reliable operation, unit should be level in all horizontal planes.
7. For interconnecting refrigerant tube lengths greater than 80 ft (23.4 m) and/or elevation differences between indoor and outdoor units greater than 20 ft (6.1 m), consult Residential Piping and Longline Guideline and Service Manual available from equipment distributor.
8. If any refrigerant tubing is buried, provide a 6 in. (152.4 mm) vertical rise to the valve connections at the unit. Refrigerant tubing lengths up to 36 in. (914.4 mm) may be buried without further consideration. Do not bury refrigerant lines longer than 36 in. (914.4 mm).
9. Use only copper wire for electric connection at unit. Aluminum and clad aluminum are not acceptable for the type of connector provided.
10. Do not apply capillary tube indoor coils to these units.
11. Factory-supplied filter drier must be installed.