





Verify that you have the most current version of this document from [www.hvacpartners.com](http://www.hvacpartners.com) or your local Carrier office.

Important changes are listed in **Document revision history** at the end of this document.

CARRIER CORPORATION ©2017. All rights reserved throughout the world. i-Vu is a registered trademark of Carrier Corporation. All other trademarks are the property of their respective owners.

# Contents

<b>Introduction</b> .....	<b>1</b>
What are the UC Open XP and UC Open XP IO?.....	1
UC Open XP specifications .....	2
UC Open XP IO specifications .....	4
Safety considerations.....	5
<b>Installing the UC Open XP</b> .....	<b>6</b>
Mounting the UC Open XP .....	6
Wiring the UC Open XP for power.....	6
To wire for power.....	7
Addressing the UC Open XP .....	7
Wiring for communications.....	7
Wiring specifications for BACnet MS/TP and ARC156.....	8
To wire the controller to the network .....	8
Wiring inputs and outputs .....	9
Input wiring specifications .....	9
Inputs .....	9
Binary outputs .....	10
Analog outputs .....	10
To wire inputs and outputs on the UC Open XP.....	11
<b>Installing the UC Open XP IO expander</b> .....	<b>14</b>
To mount and attach the UC Open XP IO .....	14
To wire for power .....	15
Wiring inputs and outputs .....	15
Input wiring specifications .....	16
Inputs on the UC Open XP IO .....	16
Binary outputs .....	16
To wire inputs and outputs on UC Open XP IO.....	17
Wiring devices to the UC Open XP's Rnet port.....	18
Rnet wiring specifications.....	19
ZS sensor overview .....	20
SPT sensor overview .....	20
To wire the ZS or SPT sensor to the UC Open XP .....	21
Wireless sensor overview .....	21
To install the Wireless Adapter for wireless sensors.....	22
To wire an Equipment Touch to the UC Open XP.....	23
<b>Installing the UC Open XP into an i-Vu® Control System</b> .....	<b>25</b>
<b>Local access to the UC Open XP</b> .....	<b>27</b>
<b>Troubleshooting</b> .....	<b>28</b>
UC Open XP LED's.....	28
Expander LED's .....	29
To get the serial number .....	30
To restore defaults.....	30
To replace the UC Open XP's battery .....	31
<b>Compliance</b> .....	<b>32</b>
FCC Compliance.....	32
CE Compliance .....	32
BACnet Compliance.....	32
<b>Appendix A: UC Open XP and UC Open XP IO wire lists</b> .....	<b>33</b>
UC Open XP wire list .....	33
UC Open XP IO wire list .....	35

<b>Appendix B: AHU VAV input and output points list.....</b>	<b>37</b>
AHU VAV inputs and outputs on the UC Open XP .....	37
AHU VAV inputs and outputs on the UC Open XP IO .....	38
<b>Appendix C: AHU CV Open input and output points list.....</b>	<b>40</b>
AHU CV Open inputs and outputs on the UC Open XP .....	40
AHU CV Open inputs and outputs on the UC Open XP IO .....	41
<b>Document revision history .....</b>	<b>43</b>

# Introduction

## What are the UC Open XP and UC Open XP IO?

The Universal Controller Open XP (OPN-UCXP) is a general purpose controller. It provides the communications circuitry, non-volatile memory, and removable screw terminals for I/O connections.

The Universal Controller Open XP IO (OPN-UCXP10) is an expander that connects to the expandable UC Open XP, in order to increase the number of inputs and outputs.

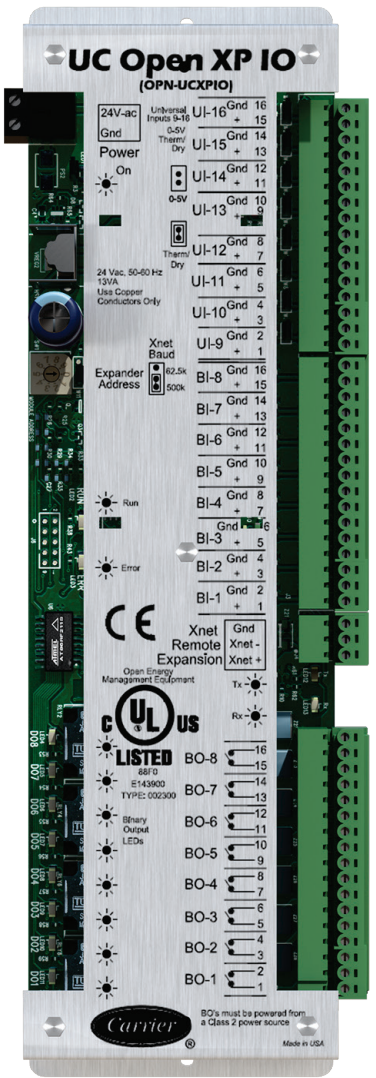
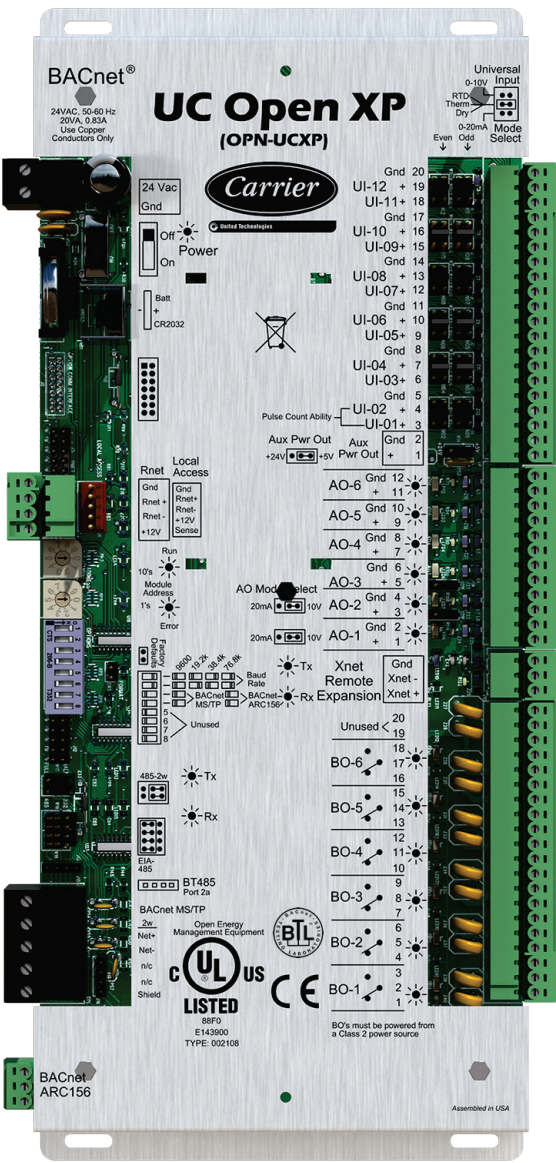

## UC Open XP specifications

---

Driver	drv_ucxpopen_std_x-xxx-xxx
Maximum number of control programs*	20
Maximum number of BACnet objects*	1050
Maximum number of third-party integration points using Snap*†	10
* Depends on available memory † BACnet third-party integration points are not counted.	
Power	24 Vac $\pm$ 10%, 50–60 Hz 20 VA power consumption 26 Vdc (25 V min, 30 V max) Single Class 2 source only, 100 VA or less
BACnet MS/TP Port	For communication with the controller network using MS/TP (9600 bps, 19.2 kbps, 38.4 kbps, or 76.8 kbps)
BACnet ARC156 Port	For communication with the controller network using ARC156
Rnet port	Supports: <ul style="list-style-type: none"> <li>• Up to 15 ZS sensors (5 per control program)</li> <li>• One Wireless Adapter that communicates with up to 15 Wireless sensors</li> <li>• One Equipment Touch</li> <li>• Up to 4 SPT Standard sensors and one SPT Plus, SPT Pro, or SPT Pro-F sensor</li> </ul> <p><b>NOTE</b> ZS sensors, a Wireless Adapter, and an Equipment Touch can share the Rnet, but not SPT sensors.</p>
Local Access port	For system start-up and troubleshooting using Field Assistant or an Equipment Touch device
Xnet Remote Expansion port	For communication with the UC Open XP IO expander.
Inputs	12 inputs configurable for 0-10 V, RTD Therm Dry, or 0-20mA. Inputs 1 and 2 may be used for pulse counting.
Input pulse frequency	10 pulses per second. Minimum pulse width (on or off time) required for each pulse is 50 msec.
Input resolution	12 bit A/D
Aux Power Output	5 Vdc or 24 Vdc input sensor power. Jumper selectable, limited to 200 mA. Available on input terminal 1.
Binary outputs	6 binary outputs, configured as dry contact, normally open or normally closed, must be powered from a Class 2 power source.

Analog outputs	6 analog outputs: <ul style="list-style-type: none"> <li>1 and 2 are configurable for 0-10 V or 0-20 mA</li> <li>3 - 6 are 0-10 V only</li> </ul>
Output resolution	8 bit D/A
Real time clock	Battery-backed real time clock keeps track of time in the event of a power failure
Battery	10-year Lithium CR2032 battery retains the following data for a maximum of 10,000 hours during power outages: control programs, editable properties, schedules, and trends.
Protection	Incoming power and network connections are protected by non-replaceable internal solid-state polyswitches that reset themselves when the condition that causes a fault returns to normal.  The power, network, input, and output connections are also protected against transient excess voltage/surge events lasting no more than 10 msec.
Status indicators	LED's indicate status of communications, running, errors, and power. LED indicators for transmit/receive for the BACnet MS/TP and ARC156 ports and for each of the 12 outputs.
Environmental operating range	0 to 140° F (-18 to 60°C), 0 to 90% relative humidity, non-condensing
Storage temperature range	-24 to 140° F (-30 to 60°C), 0 to 90% relative humidity, non-condensing
Physical	Rugged aluminum housing with removable screw terminals

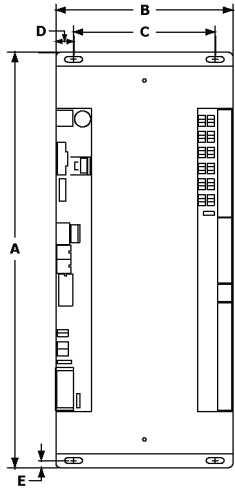

Overall dimensions	A:	11-13/16 in. (30 cm)
	B:	5 in. (12.7 cm)
Mounting dimensions	C:	4 in. (10.2 cm)
	D:	1/2 in. (1.3 cm)
	E:	13/64 in. (.5 cm)
Panel depth	2 in. (5.1 cm)	
Weight	1.1lb. (0.5 kg)	

BACnet support	Conforms to the BACnet Advanced Application Controller (B-AAC) Standard Device Profile as defined in ANSI/ASHRAE Standard 135-2012 (BACnet) Annex L, Protocol Revision 9
Listed by	UL-916, (Canadian Std C22.2 No. 205-M1983), CE, FCC Part 15-Subpart B-Class A

## UC Open XP IO specifications

Power	24 Vac $\pm 10\%$ , 50–60 Hz 13 VA power consumption 26 Vdc (25 V min, 30 V max) Single Class 2 source only, 100 VA or less
Binary inputs	BI 1 - 8 are binary only and support pulse counting up to 10 Hertz, dry contact only.
Universal inputs	UI 9 - 16 inputs are jumper selectable between thermistor/dry contact and 0-5 Vdc.
Input resolution	10 bit A/D
Input pulse frequency	10 pulses per second. Minimum pulse width (on or off time) required for each pulse is 50 msec.
Binary outputs	8 binary outputs, configured as dry contact, normally open, and must be powered from a Class 2 power source.
Protection	Incoming power and network connections are protected by non-replaceable internal solid-state polyswitches that reset themselves when the condition that causes a fault returns to normal.  The power, network, input, and output connections are also protected against transient excess voltage/surge events lasting no more than 10 msec.
Status indicators	LED's indicate status of communications, running, errors, and outputs
Environmental operating range	0 to 140° F (-18 to 60°C), 0 to 90% relative humidity, non-condensing
Storage temperature range	-24 to 140° F (-30 to 60°C), 0 to 90% relative humidity, non-condensing
Physical	Rugged aluminum housing with removable screw terminals

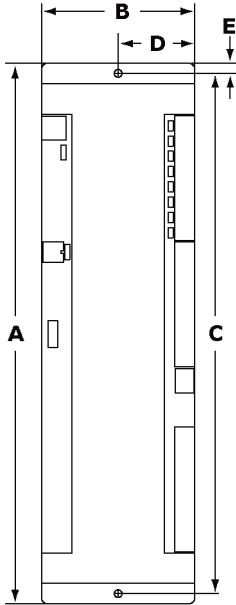

Overall dimensions	A:	10-5/8 in. (27.0 cm)
	B:	3 in. (7.6 cm)
Mounting dimensions	C:	10-3/16 in. (25.9 cm)
	D:	1-1/2 in. (3.8 cm)
	E:	13/64 in. (.5 cm)
Depth		1-1/2 in. (.8 cm)
Weight		.73 lbs (.33 kg)
Listed by		UL-916, (Canadian Std C22.2 No. 205-M1983), CE, FCC Part 15-Subpart B-Class A

## Safety considerations

 **WARNING** Disconnect electrical power to the UC Open XP before wiring it. Failure to follow this warning could cause electrical shock, personal injury, or damage to the controller.

## Installing the UC Open XP

To install the UC Open XP:

- 1 *Mount the controller (page 6).*
- 2 *Wire the controller for power (page 6).*
- 3 *Set the controller's address (page 7).*
- 4 *Wire the controller to the BACnet MS/TP or BACnet ARC156 network (page 7).*
- 5 *Wire expanders to the controller (page 14).*
- 6 *Wire inputs and outputs (page 9).*
- 7 *Wire devices to the Rnet port (page 18).*

## Mounting the UC Open XP

---

### **WARNING**

When you handle the UC Open XP:

- Do not contaminate the printed circuit board with fingerprints, moisture, or any foreign material.
- Do not touch components or leads.
- Handle the board by its edges.
- Isolate from high voltage or electrostatic discharge.
- Ensure that you are properly grounded.

Screw the UC Open XP into an enclosed panel using the mounting slots on the cover plate. Leave about 2 in. (5 cm) on each side of the controller for wiring. See mounting dimensions in Specifications.

If using expanders, see Installing an expander before mounting the controller.

## Wiring the UC Open XP for power

---

### **WARNING** Do not apply line voltage (mains voltage) to the controller's ports and terminals.

### **CAUTIONS**

- The UC Open XP is powered by a Class 2 power source. Take appropriate isolation measures when mounting it in a control panel where non-Class 2 circuits are present.
- Carrier controllers can share a power supply as long as you:
  - Maintain the same polarity.
  - Use the power supply only for Carrier controllers.

## To wire for power

- 1 Turn off the UC Open XP's power switch to prevent it from powering up before you can verify the correct voltage.
- 2 Remove primary power from the 24 Vac transformer.
- 3 Pull the screw terminal connector from the controller's power terminals labeled **Gnd** and **24 Vac**.
- 4 Connect the transformer wires to the screw terminal connector.
- 5 Apply primary power to the transformer.
- 6 Measure the voltage at the UC Open XP's power screw terminal connector to verify that the voltage is within the operating range of 21.6 - 26.4 Vac.
- 7 Insert the screw terminal connector into the UC Open XP's power terminals.
- 8 Turn on the UC Open XP's power switch.
- 9 Verify that the Power LED is on and the Run LED is blinking.

## Addressing the UC Open XP

---

The UC Open XP's two rotary switches determine its MAC address when it is placed on a BACnet MS/TP network. The rotary switches define the MAC address portion of the device's BACnet address, which is composed of the network address and the MAC address.

- 1 Turn on the controller's power.
- 2 Using the rotary switches, set the controller's address. Set the **Tens (10's)** switch to the tens digit of the address, and set the **Ones (1's)** switch to the ones digit.

**EXAMPLE** If the controller's address is 25, point the arrow on the **Tens (10's)** switch to 2 and the arrow on the **Ones (1's)** switch to 5.

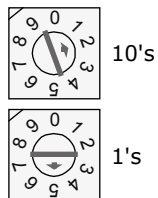

- 3 Turn on the controller's power.

**NOTE** The controller reads the address each time you apply power to it.



**CAUTION** The factory default setting is **00** and must be changed to successfully install your UC Open XP.

## Wiring for communications

---

The UC Open XP communicates using BACnet on the following types of network segments:

- MS/TP communicating at 9600 bps, 19.2 kbps, 38.4 kbps, or 76.8 kbps
- ARC156 communicating at 156 kbps

**NOTE** For more networking details, see the *Open Controller Network Wiring Installation Guide*.

## Wiring specifications for BACnet MS/TP and ARC156

Cable:	22 AWG or 24 AWG, low-capacitance, twisted, stranded, shielded copper wire
Maximum length:	2000 feet (610 meters)



**WARNING** Do not apply line voltage (mains voltage) to the controller's ports and terminals.

### To wire the controller to the network

- 1 Pull the screw terminal connector from the controller's power terminals labeled **Gnd** and **24 Vac**.
- 2 Check the communications wiring for shorts and grounds.
- 3 Connect the communications wiring to the BACnet MS/TP **or** to the BACnet ARC156 port.  
**NOTE** Use the same polarity throughout the network segment.
- 4 For MS/TP, verify the jumpers are set to 485-2w and EIA-485. They are not used for ARC156.
- 5 Set the communication type and baud rate.

For...	Set Communications Selection Jumper to...	Set DIP switches 1 and 2 to...	Set DIP switches 3 and 4 to...
MS/TP	<b>MS/TP</b>	The appropriate baud rate. See the <b>MS/TP Baud</b> diagram on the controller.	Off/Off
ARC156	<b>ARC156</b>	N/A. Baud rate will be 156 kbps regardless of the DIP switch settings.	On/On

**NOTE** Use the same baud rate for all controllers on the network segment.

- 6 Wire the controllers on an MS/TP or ARC156 network segment in a daisy-chain configuration.
- 7 If the UC Open XP is at either end of a network segment, connect a BT485 to the UC Open XP.
- 8 Insert the power screw terminal connector into the UC Open XP's power terminals.
- 9 Verify communication with the network by viewing a Module Status report in the i-Vu® interface.

## Wiring inputs and outputs



**WARNING** Do not apply line voltage (mains voltage) to the controller's ports and terminals.

See *Appendix A* (page 33) to print a blank wire list.

### Input wiring specifications

Input	Maximum length	Minimum gauge	Shielding
0–5 Vdc 0–10 Vdc	500 feet (152 meters)	22 AWG	100 feet Unshielded 100 - 500 feet Shielded
0–20 mA	1000 feet (305 meters)	22 AWG	100 feet Unshielded 100 - 1000 feet Shielded
Thermistor Dry contact Pulse counter TLO	500 feet (152 meters)	22 AWG	100 feet Unshielded 100 - 500 feet Shielded
RTD	100 feet (30 meters)	22 AWG	Shielded
ZS or SPT sensors	500 feet (152 meters)	18 AWG 22 AWG	Shielded or unshielded
Wireless Adapter for Wireless sensors	500 feet (152 meters)	22 AWG	Shielded or unshielded
Equipment Touch device	500 feet (152 meters)	22 AWG (7x0096) bare copper	If shielded, Aluminum/Mylar shield (100% coverage) with TC drain wire

### Inputs

The UC Open XP has 12 inputs that accept the following signal types.

Signal Type	Description
Thermistor	Precon type 2 (10 kOhm at 77 °F). Input voltages should be from 0.489 Vdc to 3.825 Vdc for thermistors.
Dry contact	A 5 Vdc wetting voltage detects contact position, resulting in a 1 mA maximum sense current when the contacts are closed.
0–5 Vdc 0–10 Vdc	The input impedance of the UC Open XP is approximately 20 kOhm.

Signal Type	Description
0–20 mA	The input resistance on the positive (+) terminal is 250 Ohms. The <b>Aux Power Out</b> connector is capable of supplying 24 Vdc to multiple 4–20 mA transducers, but the total current demanded must not exceed 200 mA. If the voltage measured from the <b>Aux Power Out</b> connector to <b>Gnd</b> is less than 18 Vdc, you need to use an external power supply.
RTD	Platinum - 1 kOhm at 32 °F (0 °C) Nickel/Iron - 1 kOhm at 70 °F (21 °C) Balco TS8000 - 1 kOhm at 70 °F (21 °C) Input voltages should be from 0.6–1.2 V
Pulse counter*	UI-2 and UI-2 only:  Maximum of 10 pulses per second. Minimum pulse width required for each pulse: <ul style="list-style-type: none"> <li>• ON to OFF time (half cycle) is 50 msec</li> <li>• ON to OFF to ON time (full cycle) is msec</li> </ul>

\* The UC Open XP can perform pulse counting for dry contact or voltage inputs if you assign the input to a Pulse to Analog Input microblock.

## Binary outputs

The UC Open XP has 6 binary outputs. Each output is a dry contact that must be powered from a Class 2 power source.

To size output wiring, consider the following:

- Total loop distance from the power supply to the controller, and then to the controlled device  
**NOTE** Include the total distance of actual wire. For 2-conductor wires, this is twice the cable length.
- Acceptable voltage drop in the wire from the controller to the controlled device
- Resistance (Ohms) of the chosen wire gauge
- Maximum current (Amps) the controlled device requires to operate

## Analog outputs

The UC Open XP has 6 analog outputs:

- 1 and 2 are configurable for 0-10 V or 0-20 mA
- 3, 4, 5, and 6 are 0-10 V only

The controlled device must share the same ground as the UC Open XP and have the following input impedance:

0–10 Vdc	min 500 Ohms
0–20 mA	max 800 Ohms

## To wire inputs and outputs on the UC Open XP

- 1 Turn **off** the UC Open XP's power.
- 2 Connect the input wiring to the screw terminals on the UC Open XP.

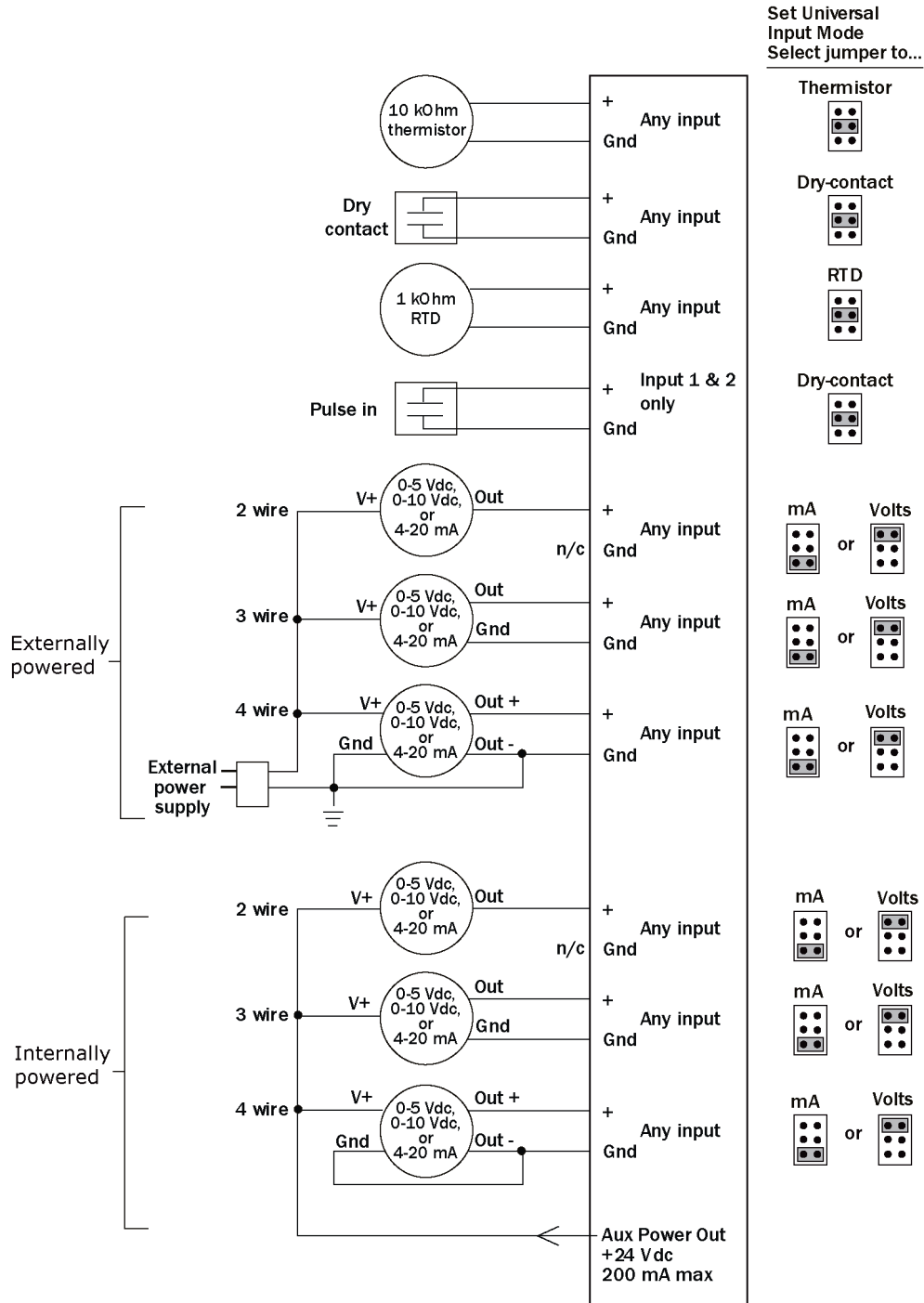

**NOTES**

- If using shielded wire, connect the shield to the GND terminal with the ground wire. Tape off the shield wire at the sensor end.
- Connect the shield wire to the **GND** terminal with the ground wire.
- Use only UI-1 or UI-2 for pulse counter or timed local override.
- For an internally-powered 4-20 mA sensor, wire the sensor's positive terminal to the **+** terminal on the UC Open XP's **Aux Power Out** port. Wire the sensor's negative terminal to an input's **+** terminal.

**3** Set the appropriate jumpers on the UC Open XP.

To use...	For...																														
Any input	Thermistor Dry contact 0-5 Vdc 0-10 Vdc 0-20 mA RTD	Set each input's <b>Universal Input Mode Select</b> jumper to the type of signal the input will receive.	<table border="0"> <tr> <td></td> <td>Even</td> <td>Odd</td> <td></td> </tr> <tr> <td>12</td> <td></td> <td></td> <td>11</td> </tr> <tr> <td>10</td> <td></td> <td></td> <td>9</td> </tr> <tr> <td>8</td> <td></td> <td></td> <td>7</td> </tr> <tr> <td>6</td> <td></td> <td></td> <td>5</td> </tr> <tr> <td>4</td> <td></td> <td></td> <td>3</td> </tr> <tr> <td>2</td> <td></td> <td></td> <td>1</td> </tr> </table>		Even	Odd		12			11	10			9	8			7	6			5	4			3	2			1
	Even	Odd																													
12			11																												
10			9																												
8			7																												
6			5																												
4			3																												
2			1																												
Aux Power Out port	Internally-powered 4-20 mA	Set the <b>Select</b> jumper to <b>+5V</b> or <b>+24V</b> as required by the sensor.																													

**4** Connect the binary output wiring to the screw terminals on the UC Open XP and to the controlled device.

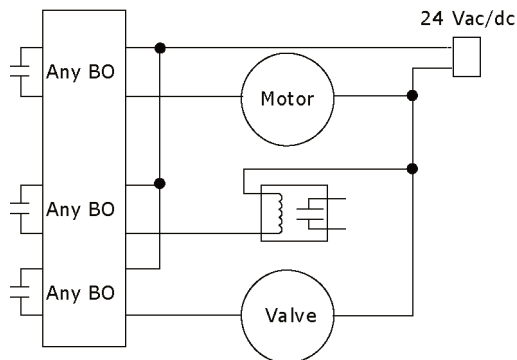

- 5 Connect the analog output wiring to the screw terminals on the UC Open XP and to the controlled device.

Set AO Mode Select jumper to...

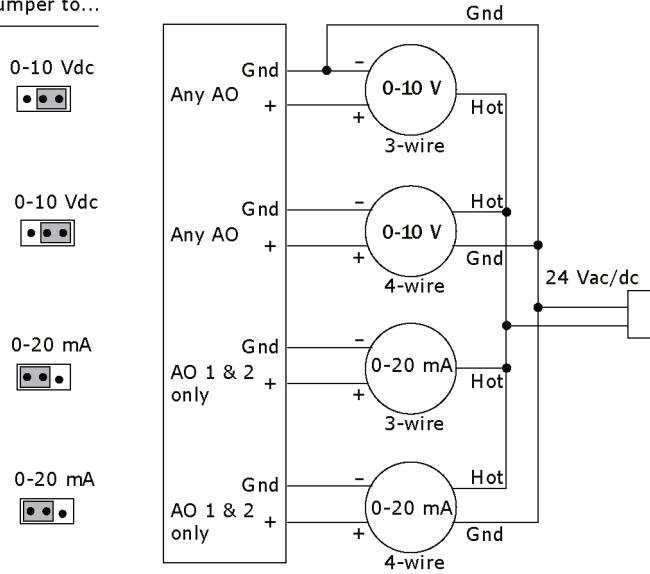

- 6 Set the **AO Mode Select** jumper to the type of device you are wiring the output to.
- 7 Turn **on** the UC Open XP's power.

## Installing the UC Open XP IO expander

- 1 *Mount the expander.* (page 14)
- 2 *Wire the expander for power.* (page 15)
- 3 *Wire inputs and outputs.* (page 17)



**CAUTION** Do not change the rotary switch address from the default setting of 1.

## To mount and attach the UC Open XP IO



### WARNING

When you handle the UC Open XP IO:

- Do not contaminate the printed circuit board with fingerprints, moisture, or any foreign material.
- Do not touch components or leads.
- Handle the board by its edges.
- Isolate from high voltage or electrostatic discharge.
- Ensure that you are properly grounded.

Wiring restrictions for connecting the UC Open XP IO to the UC Open XP

- Maximum length: 100 feet (30 meters)
- 22 or 24 AWG, low-capacitance, twisted, stranded, shielded copper wire

You can mount the UC Open XP IO in one of the following locations:

- On top of a UC Open XP, using the two allen cap screws provided. Connect Gnd to Gnd, Xnet- to Xnet-, Xnet+ to Xnet+.

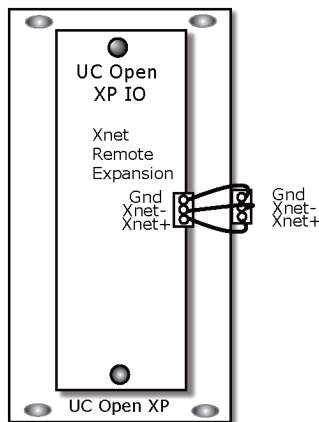

- Beside the UC Open XP, by screwing the UC Open XP IO into an enclosed panel using the mounting slots on the cover plate. Leave about 2 in. (5 cm) on each side of the expander for wiring. Mounting hole dimensions 1.5" from the left (width) by 10.2" (height). Connect Gnd to Gnd, Xnet- to Xnet-, Xnet+ to Xnet+. You can mount the UC Open XP IO up to 100 ft away from the UC Open XP.

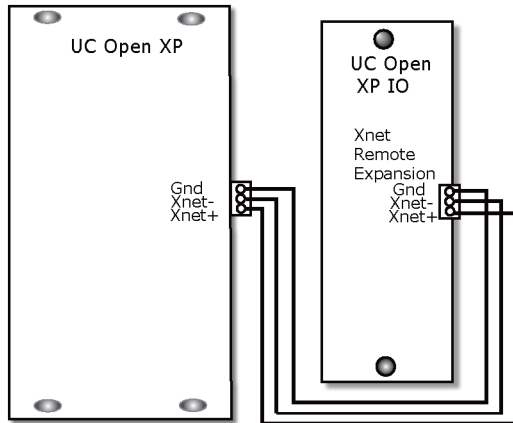

## To wire for power

Older models of the UC Open XP IO have a power jumper that you must set to turn the expander on and off.

### CAUTIONS

- The UC Open XP IO expander is powered by a Class 2 power source. Take appropriate isolation measures when mounting it in a control panel where non-Class 2 circuits are present.
- For the UC Open XP to recognize an attached expander, you must turn on the expander before you turn on the UC Open XP.

- 1 Pull the screw terminal connector from the controller's power terminals labeled **Gnd** and **24 Vac**.
- 2 Ground shielded wire to the UC Open XP IO's ground terminal.
- 3 Set the configuration jumpers for inputs 9 through 16 for thermistor/dry contact or 0-5 Vdc.
- 4 Insert the power screw terminal connector into the UC Open XP's power terminals.
- 5 Verify that the **Power** LED is on and the **Run** LED is blinking.

## Wiring inputs and outputs



**WARNING** Do not apply line voltage (mains voltage) to the controller's ports and terminals.

See *Appendix A* (page 33) to print a blank wire list.

## Input wiring specifications

Input	Maximum length	Minimum gauge	Shielding
0-5 Vdc	500 feet (152 meters)	22 AWG	100 feet Unshielded 100 - 500 feet Shielded
Thermistor Dry contact Pulse counter TLO	500 feet (152 meters)	22 AWG	100 feet Unshielded 100 - 500 feet Shielded

## Inputs on the UC Open XP IO

The UC Open XP IO has 16 inputs that accept the following signal types:

Signal Type	Description
Thermistor	Precon type 2 (10 kOhm at 77°F). Input voltages should be from 0.489 Vdc to 3.825 Vdc for thermistors.
Dry contact	A 5 Vdc wetting voltage detects contact position, resulting in a 1 mA maximum sense current when the contacts are closed.
0-5 Vdc	The input impedance of the UC Open XP IO is approximately 20 kOhm.
Pulse counter	10 pulses per second. Minimum pulse width (on or off time) required for each pulse is 50 msec.

## Binary outputs

The UC Open XP IO has 8 binary outputs. Each output is a dry contact that must be powered from a Class 2 power source.

To size output wiring, consider the following:

- Total loop distance from the power supply to the expander, and then to the controlled device  
**NOTE** Include the total distance of actual wire. For 2-conductor wires, this is twice the cable length.
- Acceptable voltage drop in the wire from the expander to the controlled device
- Resistance (Ohms) of the chosen wire gauge
- Maximum current (Amps) the controlled device requires to operate

## To wire inputs and outputs on UC Open XP IO

- 1 Verify that the UC Open XP IO's power and communications connections work properly.
- 2 Pull the screw terminal connector from the controller's power terminals labeled **Gnd** and **24 Vac**.
- 3 Connect the input wiring to the screw terminals on the UC Open XP IO.

**NOTE** Connect the shield wire to the **GND** terminal with the ground wire.

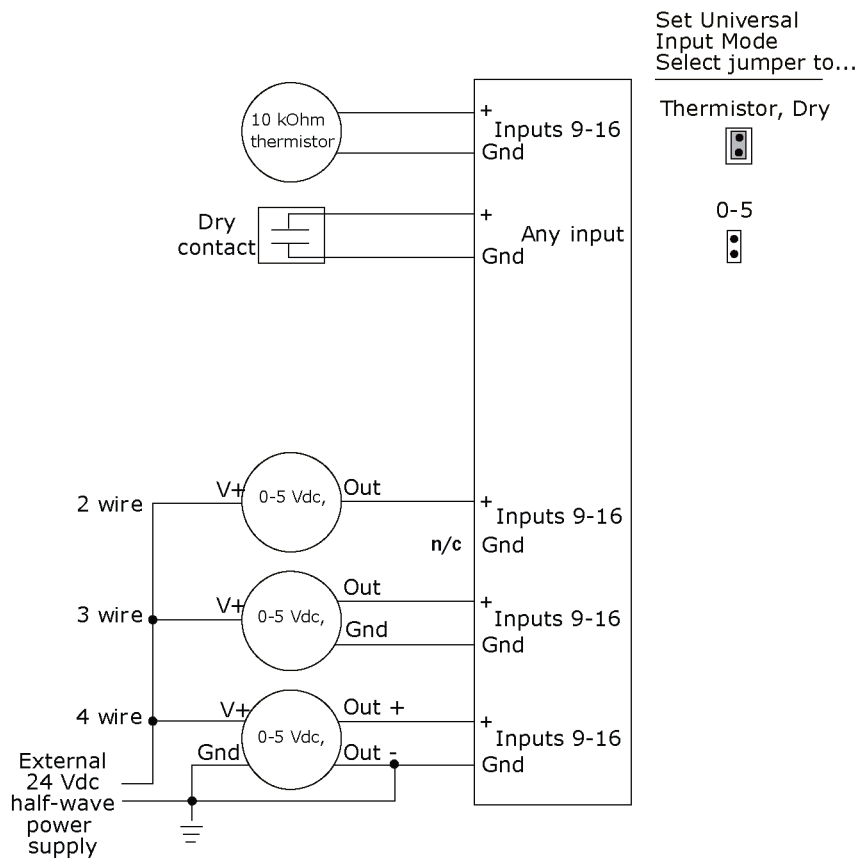

- 4 Set each input's **Universal Input Mode Select** jumper to indicate the type of input.  
**WARNING** Do not apply 24 Vac to these universal inputs.
- 5 Connect binary output wiring to the **BO** screw terminals on the UC Open XP IO and to the controlled device.
- 6 Wire **GND** for each binary output to its even-numbered terminal.

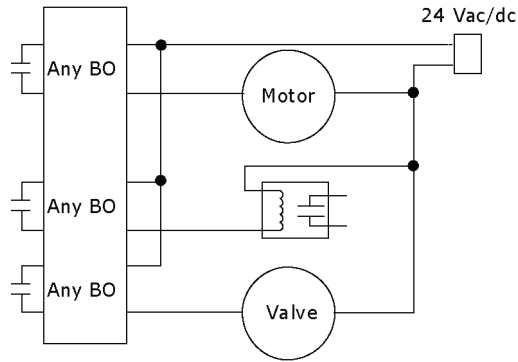

- 7 Insert the power screw terminal connector into the UC Open XP's power terminals.

## Wiring devices to the UC Open XP's Rnet port

---

The Rnet communicates at a rate of 115 kbps.

### Carrier wireless sensors

You can wire a Wireless Adapter to UC Open XP's **Rnet** port. The Wireless Adapter communicates with up to 15 wireless sensors. When using wireless sensors, the Rnet can have:

- Up to 15 wireless and ZS sensors (any combination)
- One Wireless Adapter
- One Equipment Touch

### ZS sensors

You can wire up to 15 ZS sensors to the UC Open XP's **Rnet** port. ZS sensors can share the Rnet with the devices listed above.

#### NOTES

- A control program can use no more than 5 ZS sensors, so you must use multiple control programs if your Rnet network has more than 5 sensors.
- The ZS CO2 model uses 190 mA during sample period. Use auxiliary 12 Vdc, unless it is the only device on the Rnet port.

## SPT sensors

You can wire SPT sensors to the UC Open XP's **Rnet** port. An Rnet can consist of any of the following combinations of devices wired in a daisy-chain or star configuration:

- 1 SPT Plus, SPT Pro, or SPT Pro-F
- 1–4 SPT Standards
- 1–4 SPT Standards, and 1 SPT Plus, SPT Pro, or SPT Pro-F

**NOTE** SPT sensors cannot share the Rnet with other devices.

## Equipment Touch

You can wire an Equipment Touch to the UC Open XP's Rnet port to view or change the controller's property values, schedule equipment, view trends and alarms, and more, without having to access the system's server. The Rnet can have one Equipment Touch, one Wireless Adapter, and up to 15 ZS sensors. SPT sensors cannot share the Rnet with an Equipment Touch.



### CAUTIONS

- Equipment Touch requires 24 Vac and cannot be powered by Rnet's 12 Vdc. For more details, see the *Equipment Touch Installation and Setup Guide*.

If you exceed 200 mA, then one or more devices need an auxiliary 12 Vdc power supply.

## Rnet wiring specifications

**NOTE** Use the specified type of wire and cable for maximum signal integrity.

Description	4 conductor, shielded or unshielded, CMP, plenum rated cable
Conductor	22 AWG (7x0096) bare copper if Rnet has only sensors
Maximum length	500 feet (152 meters)
Insulation	Low-smoke PVC (or equivalent)
Color Code	Black, white, green, red
Shielding	If shielded, Aluminum/Mylar shield (100% coverage) with TC drain wire, terminated at controller
UL temperature rating	32–167 °F (0–75 °C)
Voltage	300 Vac, power limited
Listing	UL: NEC CL2P, or better

## ZS sensor overview

ZS Sensors are thermistor-based temperature sensors that may optionally sense humidity, CO<sub>2</sub>, or VOC. ZS Sensors are wired to the Rnet port on most Carrier controllers.

### REQUIREMENTS

- A v6.0 or later i-Vu® system
- v6-xx-xxx or later controller drivers

You can use the following ZS sensors:

- ZS Standard
- ZS Plus
- ZS Pro
- ZS Pro-F

An Rnet can consist of the following devices wired in a daisy-chain or star configuration:

- Up to 15 ZS sensors if the controller contains multiple control programs for the sensors
- One Equipment Touch
- You cannot have SPT sensors and ZS sensors on the same Rnet.

For basic user instructions, see the *ZS Sensor User Guide*. For detailed installation instructions, see the *ZS Sensors Installation Guide*.

## SPT sensor overview

The SPT sensor is a wall-mounted space temperature sensor that monitors room temperature.

The UC Open XP supports the following:

- SPT Standard
- SPT Plus
- SPT Pro
- SPT Pro Plus

Wire the sensors to the controller's **Rnet** port.

**NOTE** If the Rnet has multiple SPT Standard sensors, you must give each a unique address on the Rnet.

For basic user instructions, see the *SPT Sensors Owner Guide*. For more detailed instructions, see the *Carrier Sensors Installation Guide*.

## To wire the ZS or SPT sensor to the UC Open XP

- 1 Partially cut, then bend and pull off the outer jacket of the Rnet cable(s). Do not nick the inner insulation. Strip about .25 inch (.6 cm) of the inner insulation from each wire.

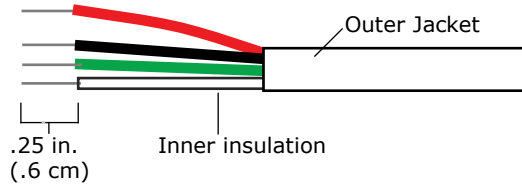

- 2 Wire each terminal on the sensor to the same terminal on the controller. See diagram below.

**NOTE** Carrier recommends that you use the following Rnet wiring scheme:

Connect this wire...	To this terminal...
Red	+12V
Black	Rnet-
White	Rnet+
Green	Gnd

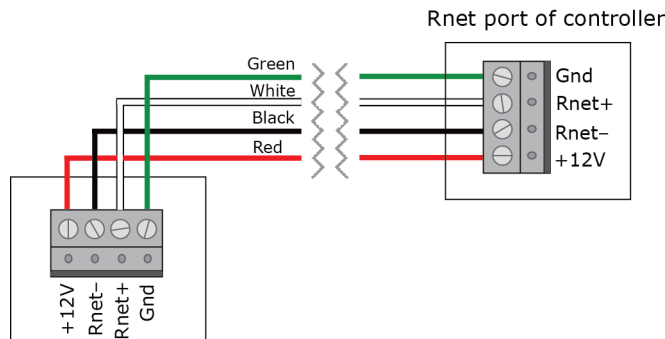

## Wireless sensor overview

The Carrier wireless sensors, designed for zone control, are low-power wireless devices that use light-harvesting through solar panels as their primary power source. The wireless line of sensors includes the models shown in the list below. All are available in 868, 902, and 928 MHz radio frequency. The sensors are thermistor-based temperature sensors that may optionally sense humidity.

Wireless sensors communicate through a Wireless Adapter, which is wired to the Rnet port of the controller.

### REQUIREMENTS

- A v6.5 or later i-Vu® system
- v6-xx-xxx or later controller drivers

The following is a list of all available wireless devices:

- Standard
- Plus
- Pro-F
- Motion/Lux Sensor
- Window/Door Sensor
- Adapter

To configure the control program for the desired user interaction with the sensor, see the *Wireless Sensors Application Guide*. For detailed instructions, see the *Wireless Sensors Installation Guide*.

## To install the Wireless Adapter for wireless sensors



**WARNING** Do not apply line voltage (mains voltage) to the Wireless Adapter.

### To wire, power, and mount the Wireless Adapter

#### NOTES

- The Wireless Adapter requires a 24 Vac or 24 Vdc power supply. It is not powered by the Rnet.
- If the Wireless Adapter will be:
  - Daisy-chained on the Rnet with ZS sensors or an Equipment Touch, use the standard 4-conductor Rnet wiring.
  - The only device on the Rnet, you can use a 3-conductor cable instead of the standard 4-conductor Rnet cable.

- 1 Turn off the power to the controller that the Wireless Adapter will be wired to.
- 2 Partially cut, then bend and pull off the outer jacket of the Rnet cable(s). Do not nick the inner insulation.

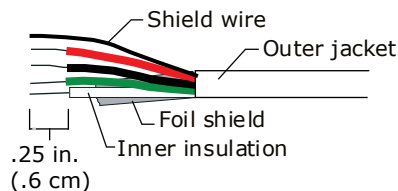

- 3 Strip about .25 inch (.6 cm) of the inner insulation from each wire.
- 4 Wire the **Rnet +**, **Rnet -**, and **Gnd** terminals on the controller's **Rnet** port to the terminals of the same name on the Wireless Adapter's Rnet connector.

**NOTE** If using shielded wire, connect the shield wire and the ground wire to the **Gnd** terminal.

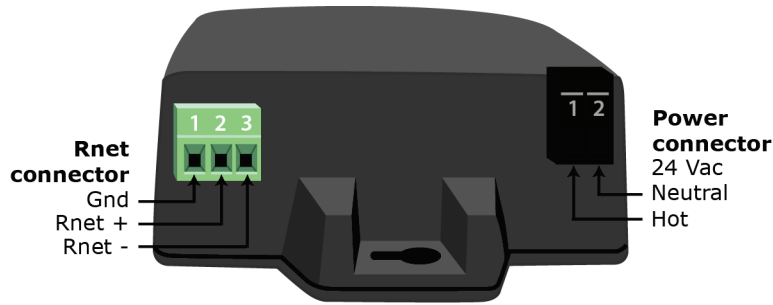

- 5 Wire the 24 Vac external power supply to the Wireless Adapter's power connector.
- 6 Mount the Wireless Adapter by inserting 2 screws through the mounting tabs on each end of the Wireless Adapter.
- 7 Apply power to the external power supply.
- 8 Verify that the LED on top of the Wireless Adapter is blinking. See "LED" below.
- 9 Turn on the controller's power.

## LED

The blue LED on the top of the Wireless Adapter indicates the following:

If the LED is...	Then the device...
Off	Is not powered or there is a problem.
Blinking	Is working properly.
Steadily on	Has a problem. Do one of the following: <ul style="list-style-type: none"> <li>• Cycle power to the device.</li> <li>• Insert a small screwdriver or paper clip into the hole next to the LED to reboot the device.</li> </ul>

## To wire an Equipment Touch to the UC Open XP

**NOTE** The Equipment Touch requires a 24 Vac power supply. It is not powered by the Rnet.



**CAUTION** Carrier controllers can share a power supply as long as you:

- Maintain the same polarity.
- Use the power supply only for Carrier controllers.

If the Equipment Touch will be:

- Daisy-chained on the Rnet with ZS sensors, use the standard 4-conductor Rnet wiring and follow the wiring instructions *To wire a ZS or an SPT sensor to the UC Open XP* (page 21).
- The only device on the Rnet, you can use a 2-conductor cable instead of the standard 4-conductor Rnet cable and follow the instructions below.

For complete Equipment Touch installation instructions including wiring diagrams, see the *Equipment Touch Installation and Setup Guide*.

- 1 Turn **off** the UC Open XP's power.
- 2 Partially cut, then bend and pull off the outer jacket of the cable. Do not nick the inner insulation.

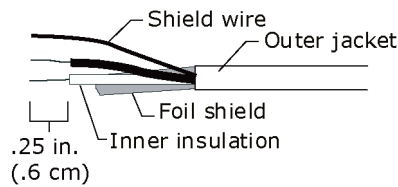

- 3 Strip about .25 inch (.6 cm) of the inner insulation from each wire.
- 4 Wire the UC Open XP's **Rnet+** and **Rnet-** terminals to the terminals of the same name on the Equipment Touch's connector.

**NOTE** If using shielded wire, connect the shield wire and the ground wire to the **Gnd** terminal.

- 5 Turn **on** the UC Open XP's power.
- 6 Turn on the Equipment Touch.

## Installing the UC Open XP into an i-Vu® Control System

You must complete the following procedures to successfully install your UC Open XP into an i-Vu® Control System. Use the Help in the referenced software for detailed descriptions of these procedures.

### EquipmentBuilder or Snap

- 1 Use EquipmentBuilder or Snap to create control program(s) for your UC Open XP.
- 2 If applicable, print the Sequence of Operation, which includes the points list.

**NOTE** You can create a points list under **Reports** in the i-Vu® application or Field Assistant after installing your control program.

### This Installation Guide

- 1 Prepare a wire list using the points list. Refer to *Appendix A* (page 33).
- 2 Use the wire list and the following installation procedures to install and wire I/O points to your UC Open XP and expander, if applicable.

### The i-Vu® or Field Assistant application

- 1 Upload the controller to the database by selecting the router in the navigation tree.
- 2 Select **Devices > Manage** tab.
- 3 Select the controller in the list on the page.
- 4 If you are adding a new control program, click **Add Control Program**. A dialog window appears.
- 5 Enter a name for your control program in **Display Name** and select your controller in the **Controller** drop-down list.

#### NOTES

- If you already have the maximum number of control programs for a controller, it will not appear in the list.
  - Optional: You can change the control program's **Reference Name** if needed.
- 6 Do one of the following:

---

#### If the control program is...

---

In the **Control Program** drop-down list

Select the control program.

Not in the **Control Program** drop-down list

- a. Click **Add New**.
  - b. Browse to select the control program.
  - c. Click **Open**.
  - d. Click **Continue**.
  - e. Click Close.
- 

- 7 To upload a graphic, click **Add New** under **Views** and browse to your .view file.
- 8 Click **Continue**. When message appears **File added successfully**, click **Close**.

- 9 Click **Close** again.
- 10 Right-click on the programmable controller in the controller list and select **Check Status** from the list. The status of the controller should say **File Mismatch**.
- 11 Click the **Download All Content** button.
- 12 Assign channel numbers to the physical points by selecting the controller in the navigation tree and going to **Properties** page > **I/O Points** tab.  
**NOTE** 39m AHU Equipment has pre-assigned IO channels. See *Appendix B* (page 37) for AHU VAV and *Appendix C* (page 40) for AHU CV Open. You must assign IO channels in all other applications by:
  - Entering your channel numbers under **Num**, using your wire list
  - Entering your expander address under **Exp**, if applicable
  - Selecting the appropriate value under **Sensor/Actuator Type**, if applicable
- 13 Configure the controller on the **Properties** page > **Control Program** tab.
- 14 Check out and commission the equipment.

## Local access to the UC Open XP

You can use the following items as a local user interface to an Open controller. These items let you access the controller information, read sensor values, and test the controller.

Connect...	To the controller's...	For...
<b>Field Assistant</b> <sup>1</sup> application	Local Access port	Temporary user interface for start-up
<b>Equipment Touch</b> <sup>2</sup> touchscreen device	Rnet port	Temporary or permanent user interface for start-up

<sup>1</sup> Requires a USB Link (Part #USB-L)

<sup>2</sup> See the *Equipment Touch Installation and Setup Guide* for detailed instructions.

 **CAUTION** If multiple controllers share power but polarity was not maintained when they were wired, the difference between the controller's ground and the computer's AC power ground could damage the USB Link and the controller. If you are not sure of the wiring polarity, use a USB isolator between the computer and the USB Link. Purchase a USB isolator online from a third-party manufacturer.

These are accessory items that do not come with the controller.

## Troubleshooting

If you have problems mounting, wiring, or addressing the UC Open XP or the UC Open XP IO, contact Carrier Control Systems Support.

**NOTE** To help you troubleshoot, obtain a Module Status (Modstat) from the controller and review the System Error and Warning details.

### UC Open XP LED's

The LED's indicate if the controller is speaking to the devices on the network. The LED's should reflect communication traffic based on the baud rate set. The higher the baud rate the more solid the LED's become.

Verify the LED patterns by cycling power to the controller and noting the lights and flashes.

LEDs	Status
Power	Lights when power is being supplied to the expander. <b>NOTE</b> The UC Open XP is protected by internal solid state Polyswitches on the incoming power and network connections. These Polyswitches are not replaceable, but they will reset themselves if the condition that caused the fault returns to normal.
Rx	Lights when the controller receives data from the network segment; there is an Rx LED for Ports 1 and 2.
Tx	Lights when the controller transmits data from the network segment; there is an Rx LED for Ports 1 and 2.
Run	Lights based on controller health.
Error	Lights based on controller health.

The **Run** and **Error** LED's indicate controller and network status.

If Run LED shows...	And Error LED shows...	Status is...
1 flash per second	1 flash per second, alternating with the <b>Run</b> LED	The controller files are archiving. Archive is complete when <b>Error</b> LED stops flashing.
2 flashes per second	Off	Normal
2 flashes per second	2 flashes, alternating with <b>Run</b> LED	Five minute auto-restart delay after system error
2 flashes per second	3 flashes, then off	The controller has just been formatted
2 flashes per second	4 flashes, then pause	Two or more devices on this network have the same network address
2 flashes per second	1 flash per second	The controller is alone on the network

If Run LED shows...	And Error LED shows...	Status Is...
2 flashes per second	On	Exec halted after frequent system errors, due to: <ul style="list-style-type: none"> <li>• Controller halted</li> <li>• Program memory corrupted</li> <li>• One or more programs stopped</li> </ul>
5 flashes per second	On	Exec start-up aborted, Boot is running
5 flashes per second	Off	Firmware transfer in progress, Boot is running
7 flashes per second	7 flashes per second, alternating with <b>Run</b> LED	Ten second recovery period after brownout
14 flashes per second	14 flashes per second, alternating with <b>Run</b> LED	Brownout
On	On	Failure. Try the following solutions: <ul style="list-style-type: none"> <li>• Turn the UC Open XP off, then on.</li> <li>• Download memory to the UC Open XP.</li> <li>• Replace the UC Open XP.</li> </ul>

**NOTE** If you resolve the issue but the **Error** LED does not turn off, cycle power to the controller.

## Expander LED's

The LED's indicate if the controller is speaking to the devices on the network. The LED's should reflect communication traffic based on the baud rate set. The higher the baud rate the more solid the LED's become.

LEDs	Status
<b>Power</b>	Lights when power is being supplied to the expander.  <b>NOTE</b> The UC Open XP is protected by internal solid state Polyswitches on the incoming power and network connections. These Polyswitches are not replaceable and will reset themselves if the condition that caused the fault returns to normal.
<b>Rx</b>	Lights when the expander receives data from the network segment; there is an Rx LED for Ports 1 and 2.
<b>Tx</b>	Lights when the expander transmits data from the network segment; there is an Rx LED for Ports 1 and 2.
<b>Run</b>	Lights based on expander health. See table below.
<b>Error</b>	Lights based on expander health. See table below.

The **Run** and **Error** LED's indicate expander and network status.

If Run LED shows...	And Error LED shows...	Status is..
2 flashes per second	Off	Normal
5 flashes per second	2 flashes per second	Boot is running or driver is updating
5 flashes per second	On	Fatal error. Replace expander or return for repair.

## To get the serial number

If you need the UC Open XP's serial number when troubleshooting, the number is on:

- a sticker on the back of the main controller board
- a Module Status report (Modstat) under **Core** (or **Main**) **board hardware**

```
Core board hardware:
Type=122, Model=1, manufactured on 06/27/2013 S/N 021362247P
RAM: 512 kBytes; FLASH: 1024 kBytes, type = 3
```

To obtain a modstat in the i-Vu® interface:

- 1 Select the UC Open XP in the navigation tree.
- 2 Right-click and select **Module Status**.

## To restore defaults



**CAUTION** This erases all archived information and user-configuration settings. You will have to reconfigure all custom settings. It is recommended to restore the factory defaults only under the guidance of Carrier Control Systems Support.

To erase volatile memory data and restore factory default configuration settings:

- 1 Turn off the UC Open XP's power switch.
- 2 Put the **Factory Defaults** jumper on.
- 3 Turn on the UC Open XP's power switch.
- 4 Remove the **Factory Defaults** jumper.

## To replace the UC Open XP's battery

---

To determine when to replace the battery, remove power and measure the voltage. If the voltage is below 2.9 volts, you need to replace the battery.



**CAUTION** Power must be **ON** to the UC Open XP when replacing the battery, or your date, time, and trend data will be lost.

- 1 Remove the battery from the controller, making note of the battery's polarity.
- 2 Insert the new battery, matching the battery's polarity with the polarity indicated on the UC Open XP.

## Compliance

### FCC Compliance

---

This equipment has been tested and found to comply with the limits for a Class A digital device, pursuant to Part 15 of the FCC Rules. These limits are designed to provide reasonable protection against harmful interference when the equipment is operated in a commercial environment. This equipment generates, uses, and can radiate radio frequency energy and, if not installed and used in accordance with the instruction manual, may cause harmful interference to radio communications. Operation of this equipment in a residential area is likely to cause harmful interference in which case the user will be required to correct the interference at his own expense.



**CAUTION** Changes or modifications not expressly approved by the responsible party for compliance could void the user's authority to operate the equipment.

### CE Compliance

---



**WARNING** This is a Class A product. In a domestic environment, this product may cause radio interference in which case the user may be required to take adequate measures.

### BACnet Compliance

---



Compliance of listed products to requirements of ASHRAE Standard 135 is the responsibility of BACnet International. BTL® is a registered trademark of BACnet International.

## Appendix A: UC Open XP and UC Open XP IO wire lists

These wire lists represent all the possible points for this application. The points that are actually used in your application depend on the equipment options you select in EquipmentBuilder.

### UC Open XP wire list

**Open System Network**  
UC Open XP Universal Controller

<b>Project Name:</b>				<b>Controller:</b>				
<b>Location:</b>				<b>Network Number:</b>				
				<b>MAC Address:</b>				
Aux power	1		5V	Jumper right 2				
	1		24V	Jumper left 2				
	2		GND					
<div style="display: flex; justify-content: space-around; align-items: center;"> <div style="text-align: center;"> <p>0-10V</p>  </div> <div style="text-align: center;"> <p>RTD Thermistor Dry-contact</p>  </div> <div style="text-align: center;"> <p>0-20mA</p>  </div> </div> <p>Universal Input Mode Select (Jumper Position of Pins)</p>								
Point/ Cable#	Inputs (+)	(G)	Input Type	Jumper Position of Pins	I/O	Sensor code	Equipment Name	Point Name
	3	5	0-10	Upper	UI-1			
	3	5	Pulse/Other	Middle				
	3	5	4-20	Lower				
	4	5	0-10	Upper	UI-2			
	4	5	Pulse/Other	Middle				
	4	5	4-20	Lower				
	6	8	0-10	Upper	UI-3			
	6	8	Other	Middle				
	6	8	4-20	Lower				
	7	8	0-10	Upper	UI-4			
	7	8	Other	Middle				
	7	8	4-20	Lower				
	9	11	0-10	Upper	UI-5			
	9	11	Other	Middle				
	9	11	4-20	Lower				
	10	11	0-10	Upper	UI-6			
	10	11	Other	Middle				
	10	11	4-20	Lower				
	12	14	0-10	Upper	UI-7			
	12	14	Other	Middle				
	12	14	4-20	Lower				
	13	14	0-10	Upper	UI-8			

Appendix A: UC Open XP and UC Open XP IO wire lists

	13	14	Other	Middle				
	13	14	4-20	Lower				
	15	17	0-10	Upper	UI-9			
	15	17	Other	Middle				
	15	17	4-20	Lower				
	16	17	0-10	Upper	UI-10			
	16	17	Other	Middle				
	16	17	4-20	Lower				
	18	20	0-10	Upper	UI-11			
	18	20	Other	Middle				
	18	20	4-20	Lower				
	19	20	0-10	Upper	UI-12			
	19	20	Other	Middle				
	19	20	4-20	Lower				

Point/ Cable#	Analog Outs (+)	(G)	A-Output Type	Jumper Position of Pins	I/O	Sensor code	Equipment Name	Point Name
	1	2	mA	Left 2 pins	AO-1			
			Volt	Right 2 pins				
	3	4	mA	Left 2 pins	AO-2			
			Volt	Right 2 pins				
	5	6	0-10	N/A	AO-3			
	7	8	0-10	N/A	AO-4			
	9	10	0-10	N/A	AO-5			
	11	12	0-10	N/A	AO-6			

Point/ Cable#	Binary Outs (+)	(G)	B-Output Type	Jumper Position of Pins	I/O	Sensor code	Equipment Name	Point Name
	1	2	N.C.	N/A	B0-1			
	3	2	N.O.					
	4	5	N.C.	N/A	B0-2			
	6	5	N.O.					
	7	8	N.C.	N/A	B0-3			
	9	8	N.O.					
	10	11	N.C.	N/A	B0-4			
	12	11	N.O.					
	13	14	N.C.	N/A	B0-5			
	15	14	N.O.					
	16	17	N.C.	N/A	B0-6			
	18	17	N.O.					

**NOTE** Only UI-1 and UI-2 have Pulse Count Ability (meter).

## UC Open XP IO wire list

<b>Open System Network</b> UC Open XP IO Universal Controller Expander								
<b>Project Name:</b>				<b>Controller:</b>				
<b>Location:</b>				<b>Network Number:</b>				
				<b>MAC Address:</b>				
Point/ Cable#	Inputs (+)	(G)	Input Type	Jumper Position of Pins		Sensor code	Equipment Name	Point Name
	1	2	BI			BI-1		
	3	4	BI			BI-2		
	5	6	BI			BI-3		
	7	8	BI			BI-4		
	9	10	BI			BI-5		
	11	12	BI			BI-6		
	13	14	BI			BI-7		
	15	16	BI			BI-8		
	1	2	0-5V	No Jumper		UI-9		
	1	2	Therm/Dry Contact	Jumper				
	3	4	0-5V	No Jumper		UI-10		
	3	4	Therm/Dry Contact	Jumper				
	5	6	0-5V	No Jumper		UI-11		
	5	6	Therm/Dry Contact	Jumper				
	7	8	0-5V	No Jumper		UI-12		
	7	8	Therm/Dry Contact	Jumper				
	9	10	0-5V	No Jumper		UI-13		
	9	10	Therm/Dry Contact	Jumper				
	11	12	0-5V	No Jumper		UI-14		
	11	12	Therm/Dry Contact	Jumper				
	13	14	0-5V	No Jumper		UI-15		
	13	14	Therm/Dry Contact	Jumper				
	15	16	0-5V	No Jumper		UI-16		
	15	16	Therm/Dry Contact	Jumper				
Point/ Cable#	Binary Outs (+)	(G)	B-Output Type	Jumper Position of Pins		Sensor code	Equipment Name	Point Name
	1	2	N.O.	N/A		B0-1		
	3	4	N.O.	N/A		B0-2		

Appendix A: UC Open XP and UC Open XP IO wire lists

	5	6	N.O.	N/A	B0-3			
	7	8	N.O.	N/A	B0-4			
	9	10	N.O.	N/A	B0-5			
	11	12	N.O.	N/A	B0-6			
	13	14	N.O.	N/A	B0-7			
	15	16	N.O.	N/A	B0-8			

**NOTE** All inputs can be pulse inputs.

## Appendix B: AHU VAV input and output points list

These wire lists represent all the possible points for this application. The points that are actually used in your application depend on the equipment options you select in EquipmentBuilder.

### AHU VAV inputs and outputs on the UC Open XP

I/O	Type	I/O Terminal	Gnd Terminal	Point Name/ Function	Hardware/ Signal	Jumper Position of Pins
UI-1	BI	3	5	Filter Status 1	Dry Contact	Middle
UI-2	AI	4	5	Supply Air Temp/ Cold Deck Temp	10K Thermistor	Middle
UI-3	AI	6	8	Mixed Air Temp	10K Thermistor	Middle
UI-4	AI	7	8	Outdoor Air Temp	5K Thermistor	Middle
UI-5	BI	9	11	Freezestat	Dry Contact	Middle
UI-6	BI	10	11	Supply Fan Status	Dry Contact	Middle
UI-7	AI	12	14	Return Air Temp	10K Thermistor	Middle
UI-8	AI	13	14	Space RH	4-20mA transmitter	Lower
UI-9	AI	15	17	Duct Static Pressure	4-20mA transmitter	Lower
UI-10	AI	16	17	Indoor Air Quality (CO2)	4-20mA transmitter	Lower
UI-11	AI	18	20	Outdoor Air Quality (CO2)	4-20mA transmitter	Lower
UI-12	AI	19	20	Building Pressure	4-20mA transmitter	Lower
BO-1	BO		2	Supply Fan S/S	Relay	N/A
BO-2	BO		5	Humidifier Enable	Relay	N/A
BO-3	BO		8	Return/Exhaust Fan S/S	Relay	N/A
BO-4	BO		11	DX Stage 1	Relay	N/A
BO-5	BO		14	DX Stage 2	Relay	N/A
BO-6	BO		17	DX Stage 3	Relay	N/A
AO-1	AO	1	2	Modulating OA Damper	0-10 Volt	N/A
AO-2	AO	3	4	Modulating HW Valve/Electric Heat Staging*	0-10 Volt	N/A
AO-3	AO	5	6	Modulating CW Valve/ F & B Damper	0-10 Volt	N/A
AO-4	AO	7	8	Supply Fan VFD	0-10 Volt	N/A
AO-5	AO	9	10	Return Fan VFD	0-10 Volt	N/A
AO-6	AO	11	12	Preheat Valve/FB Damper	0-10 Volt	N/A

I/O	Type	I/O Terminal	Gnd Terminal	Point Name/ Function	Hardware/ Signal	Jumper Position of Pins
<p>Legend</p> <p><b>AI</b> - Analog Input    <b>AO</b> - Analog Output  <b>BI</b> - Binary Input    <b>BO</b> - Binary Output</p> <p>* Electric Heat Staging AO is output to a Stage Sequencer</p> <p><b>NOTE</b> Connect ZS sensor, SPT sensor, or Wireless Adapter for the Wireless sensor to the Rnet port.</p>						

## AHU VAV inputs and outputs on the UC Open XP IO

I/O	Type	Input Terminal	Gnd Terminal	Point Name/ Function	Hardware/ Signal	Jumper position of terminals
BI-1	BI	1	2	Return/Exhaust Fan Status	Dry Contact	Middle
BI-2	BI	3	4	High Duct RH	Dry Contact	Middle
BI-3	BI	5	6	Fire Shutdown - FSD	Dry Contact	Middle
BI-4	BI	7	8	Smoke Evacuation- EVAC	Dry Contact	Middle
BI-5	BI	9	10	Smoke Pressurization - PRESS	Dry Contact	Middle
BI-6	BI	11	12	Smoke Purge - PURGE	Dry Contact	Middle
BI-7	BI	13	14	Enthalpy Switch Input	Dry Contact	Middle
BI-8						
UI-9	AI	1	2	Preheat Coil Temp	10K Thermistor	Middle
UI-10						
UI-11						
UI-12						
UI-13						
UI-14						
UI-15						
UI-16	BI	15	16	Filter Status 2	Relay	N/A
BO-1	BO	1	2	F&B 2 Pos Hot Water Valve	Relay	N/A
BO-2	BO	3	4	F&B 2 Pos Chilled Water Valve	Relay	N/A
BO-3	BO	5	6	DX Stage 4	Relay	N/A
BO-4	BO	7	8	DX Stage 5	Relay	N/A
BO-5	BO	9	10	DX Stage 6	Relay	N/A
BO-6	BO	11	12	Preheat 2 Pos Hot Water valve	Relay	N/A
BO-7	BO	13	14	Smoke Control K1	Relay	N/A
BO-8	BO	15	16	Smoke Control K2	Relay	N/A

I/O	Type	Input Terminal	Gnd Terminal	Point Name/ Function	Hardware/ Signal	Jumper position of terminals
<p>Legend</p> <p><b>UI</b> - Universal Input</p> <p><b>BI</b> - Binary Input</p> <p><b>BO</b> - Binary Output</p>						

## Appendix C: AHU CV Open input and output points list

These wire lists represent all the possible points for this application. The points that are actually used in your application depend on the equipment options you select in EquipmentBuilder.

### AHU CV Open inputs and outputs on the UC Open XP

I/O	Type	I/O Terminal	Gnd Terminal	Point Name/ Function	Hardware/ Signal	Jumper Position of Pins
UI-1	BI	3	5	Filter Status 1	Dry Contact	Middle
UI-2	AI	4	5	Supply Air Temp/ Cold Deck Temp	10K Thermistor	Middle
UI-3	AI	6	8	Mixed Air Temp	10K Thermistor	Middle
UI-4	AI	7	8	Outdoor Air Temp	5K Thermistor	Middle
UI-5	BI	9	11	Freezestat	Dry Contact	Middle
UI-6	BI	10	11	Supply Fan Status	Dry Contact	Middle
UI-7	AI	12	14	Return Air Temp	10K Thermistor	Middle
UI-8	AI	13	14	Space RH	4-20mA transmitter	Lower
UI-9				N/A		
UI-10	AI	16	17	Indoor Air Quality (CO2)	4-20mA transmitter	Lower
UI-11	AI	18	20	Outdoor Air Quality (CO2)	4-20mA transmitter	Lower
UI-12				N/A		
BO-1	BO		2	Supply Fan S/S	Relay	N/A
BO-2	BO		5	Humidifier Enable	Relay	N/A
BO-3	BO		8	Return/Exhaust Fan S/S	Relay	N/A
BO-4	BO		11	DX Stage 1	Relay	N/A
BO-5	BO		14	DX Stage 2	Relay	N/A
BO-6	BO		17	DX Stage 3	Relay	N/A
AO-1	AO	1	2	Modulating OA Damper	0-10 Volt	N/A
AO-2	AO	3	4	Modulating HW Valve/Electric Heat Staging*	0-10 Volt	N/A
AO-3	AO	5	6	Modulating CW Valve/ F & B Damper	0-10 Volt	N/A
AO-4				N/A		
AO-5				N/A		
AO-6	AO	11	12	Preheat Valve/FB Damper	0-10 Volt	N/A

I/O	Type	I/O Terminal	Gnd Terminal	Point Name/ Function	Hardware/ Signal	Jumper Position of Pins
Legend						
<b>AI</b> - Analog Input		<b>AO</b> - Analog Output				
<b>BI</b> - Binary Input		<b>BO</b> - Binary Output				
<b>NOTE</b> Connect ZS sensors, SPT sensors, or the Wireless Adapter for Wireless sensors to the Rnet port.						

## AHU CV Open inputs and outputs on the UC Open XP IO

I/O	Type	Input Terminal	Gnd Terminal	Point Name/ Function	Hardware/ Signal	Jumper position of terminals
BI-1	BI	1	2	Return/Exhaust Fan Status	Dry Contact	Middle
BI-2	BI	3	4	High Duct RH	Dry Contact	Middle
BI-3	BI	5	6	Fire Shutdown - FSD	Dry Contact	Middle
BI-4	BI	7	8	Smoke Evacuation- EVAC	Dry Contact	Middle
BI-5	BI	9	10	Smoke Pressurization - PRESS	Dry Contact	Middle
BI-6	BI	11	12	Smoke Purge - PURGE	Dry Contact	Middle
BI-7	BI	13	14	Enthaply Switch Input	Dry Contact	Middle
BI-8						
UI-9	AI	1	2	Preheat Coil Temp	10K Thermistor	Middle
UI-10						
UI-11						
UI-12						
UI-13						
UI-14						
UI-15						
UI-16	BI	15	16	Filter Status 2	Relay	N/A
BO-1	BO	1	2	F&B 2 Pos Hot Water Valve	Relay	N/A
BO-2	BO	3	4	F&B 2 Pos Chilled Water Valve	Relay	N/A
BO-3	BO	5	6	DX Stage 4	Relay	N/A
BO-4	BO	7	8	DX Stage 5	Relay	N/A
BO-5	BO	9	10	DX Stage 6	Relay	N/A
BO-6	BO	11	12	Preheat 2 Pos Hot Water valve	Relay	N/A
BO-7	BO	13	14	Smoke Control K1	Relay	N/A
BO-8	BO	15	16	Smoke Control K2	Relay	N/A

Appendix C: AHU CV Open input and output points list

<b>I/O</b>	<b>Type</b>	<b>Input Terminal</b>	<b>Gnd Terminal</b>	<b>Point Name/ Function</b>	<b>Hardware/ Signal</b>	<b>Jumper position of terminals</b>
<p>Legend</p> <p><b>UI</b> - Universal Input</p> <p><b>BI</b> - Binary Input</p> <p><b>BO</b> - Binary Output</p>						

## Document revision history

Important changes to this document are listed below. Minor changes such as typographical or formatting errors are not listed.

Date	Topic	Change description	Code*
2/24/17		Chaneg all "WS" to "wireless".	C-D
1/19/17	Wireless sensor overview To install the Wireless Adapter for Wireless sensors	New topics	C-D
	Wiring devices to the UC Open XP's Rnet port	Add Wireless Adapter, Wireless sensors	C-D
	Input wiring specifications	Added Wireless Adapter for Wireless sensors	C-D
	To wire the controller to the network	Added BACnet ARC156 connection information.	C-D
	Wiring for communications.	Changed from Wiring the UC Open XP to the MS/TP network	C-D
	UC Open XP specifications	Added BACnet ARC156 port.	C-D
	What are the UC Open XP and the UC Open XPIO	Changed UC Open XP to new silkscreen	
2/22/16	Local access to the UC Open XP	Added USB Link wiring caution.	C-TS-RD-E-JH
1/11/16	Expander LED's	New topic	C-D-LJ-O
8/4/14	UC Open XP specifications	Maximum number of BACnet third-party integration points using Snap - changed to unlimited, depending on memory Power - removed references to BACview Rnet port - added Equipment Touch and removed BACview Rnet port - added note that number of possible ZS sensors you can have with an Equipment Touch is 15 Local Access port - removed BACview, added Equipment Touch	C-D-LJ-O
	Wiring devices to the Rnet port	Changed from "Wiring a communicating zone sensor to the UC Open XP" Removed BACview	
	Connecting an SPT sensor	Removed BACview and added Equipment Touch	
	To wire an Equipment Touch to the UC Open XP	New topic	
	BACview devices	Removed references and topics	
	Local Access to the UC Open XP	Removed BACview and added Equipment Touch	
	To wire the Equipment Touch to the UC Open XP	Added Caution to maintain polarity and use the power supply only for Carrier controllers	C-TS-RD-E
	Restore factory defaults	Added information on using the Factory Defaults jumper	C-D-LJ-E-RD
* For internal use only			







CARRIER CORPORATION ©2017

A member of the United Technologies Corporation family · Stock symbol UTX · Catalog No. 11-808-437-01 · 2/24/2017