

LEAD FREE***Series LFM115-7****Pressure Reducing Control Valve with Downstream Surge Control Feature****Full Port Ductile Iron Single Chamber Valve****Features**

- Throttles to reduce high upstream pressure to constant lower downstream pressure
- Closes quickly when downstream pressure exceeds reduced pressure setpoint
- Ideal for use when high capacity on-off equipment is installed downstream
- Reducing and Surge Control setpoints are separately adjustable

Standard Components

- 1 – Main Valve (M100 - Single Chamber)
- 2 – Pressure Reducing Control
- 3 – Downstream Surge Control
- 4 – Fixed Orifice
- X – Isolation Cocks

Options and Accessories

- FC Flo-Clean Strainer (Standard 1¼" – 4")
- Y Y-Strainer (Replaces Flo-Clean)
- ACS Adjustable Closing Speed (Replaces Fixed Orifice)
- AOS Adjustable Opening Speed (Standard 1¼" – 4")
- P Position Indicator
- L Limit Switch

Operation

The Combination Pressure Reducing and Surge Automatic Control Valve (ACV) is designed to automatically reduce a fluctuating higher upstream pressure to a constant lower downstream pressure, and will quickly modulate toward a closed position if downstream pressure suddenly becomes greater than the desired regulated setpoint. The quick closing action prevents possible damaging high inlet pressure from passing through the valve to downstream piping. Normal regulating action is controlled by a normally open, pressure reducing pilot designed to: 1) Open (allowing fluid out of the main valve cover chamber) when downstream pressure is below the adjustable setpoint, and 2) Close (allowing fluid to fill the main valve cover chamber) when downstream pressure is above the adjustable setpoint. A decrease in downstream pressure causes the valve to modulate toward an open position, raising downstream pressure. An increase in downstream pressure causes the valve to modulate toward a closed position, lowering downstream pressure.

If downstream pressure suddenly becomes greater than the desired regulated setpoint, the normally closed surge control pilot opens and rapidly admits higher inlet pressure into the valve cover, increasing rate of valve closure. Normal pressure reducing operation resumes when downstream pressure decreases below the desired regulated setpoint.

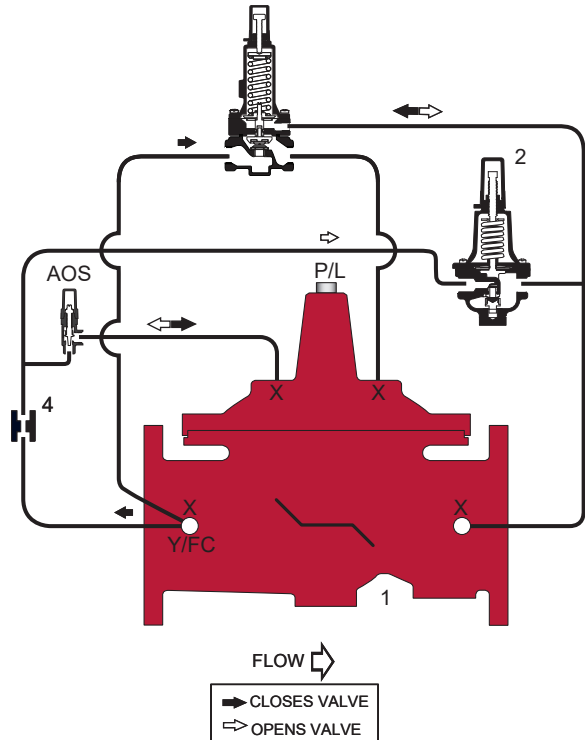

*The wetted surface of this product contacted by consumable water contains less than 0.25% of lead by weight.

NOTICE

The information contained herein is not intended to replace the full product installation and safety information available or the experience of a trained product installer. You are required to thoroughly read all installation instructions and product safety information before beginning the installation of this product.

M Series Basic Valves

Pressure Reducing Control Valve with Downstream Surge Control Feature

Full Port Ductile Iron Single Chamber Basic Valve

This Watts Automatic Control Valve (ACV) is a full port, single chamber basic valve that incorporates a one-piece disc and diaphragm assembly. This assembly is the only moving part within the valve allowing it to open, close, or modulate as commanded by the pilot control system.

Watts ACV Main Valves are Lead Free. The Watts ACV piloting system contains Lead Free* components, ensuring all of our configurations are Lead Free compliant.

Globe Pattern Single Chamber Basic Valve (M100)
Angle Pattern Single Chamber Basic Valve (M1100)

Basic Valve Body Options



Globe Flanged



Angle Flanged



Globe Grooved End



Angle Grooved End



Globe Threaded



Angle Threaded

Standard Materials

Body and Cover: Ductile Iron ASTM A536

Coating: NSF Listed Fusion Bonded Epoxy Lined and Coated

Trim: 316 Stainless Steel

Elastomers: Buna-N (standard)
EPDM (optional)
Viton® (optional)



Nut, Spring and Stem: Stainless Steel

Anti-Scale (Optional): Xylan Coated Stem and Seat

Viton® is a registered trademark of DuPont Dow Elastomers.

Operating Pressure

Threaded = 400psi (27.6 bar)
150# Flanged = 250psi (17.2 bar)
300# Flanged = 400psi (27.6 bar)
Grooved End = 400psi (27.6 bar)

Operating Temperature

Buna-N: 160°F (71°C) Maximum
EPDM: 300°F (140°C) Maximum
Viton®: 250°F (121°C) Maximum
Epoxy Coating**: 225°F (107°C) Maximum

** Valves can be provided without internal epoxy coating consult factory

ACV Schematic - Series LFM115-7

Flow Data

Valve Size - Inches		1/4	1/2	2	2 1/2	3	4	6	8	10	12	14	16
Suggested	Maximum Continuous Flow Rate Gpm (Water)	95	130	210	300	485	800	1850	3100	5000	7000	8500	11100
	Maximum Intermittent Flow Rate Gpm (Water)	119	161	265	390	590	1000	2300	4000	6250	8900	10800	14100
	Minimum Flow Rate Gpm (Water)	3	5	6	9	15	16	17	25	55	70	190	400
Cv	Cv Factor GPM (Globe)	26	26	48	75	112	188	387	764	1215	1734	2234	3131
	Cv Factor GPM (Angle)	26	27	57	91	125	207	571	889	1530	1945		

- Maximum continuous flow based on velocity of 20 ft. per second.
- Maximum intermittent flow based on velocity of 25 ft. per second.
- Minimum flow rates based on a 20-40 psi pressure drop.
- The C_v Factor of a valve is the flow rate in US GPM at 60°F that will cause a 1psi drop in pressure.
- C_v factor can be used in the following equations to determine Flow (Q) and Pressure Drop (ΔP):

$$Q \text{ (Flow)} = C_v \sqrt{\Delta P} \quad \Delta P \text{ (Pressure Drop)} = (Q/C_v)^2$$
- The C_v factors stated are based upon a fully open valve.
- Many factors should be considered in sizing control valves including inlet pressure, outlet pressure and flow rates.
- For sizing questions including cavitation analysis consult Watts with system details.

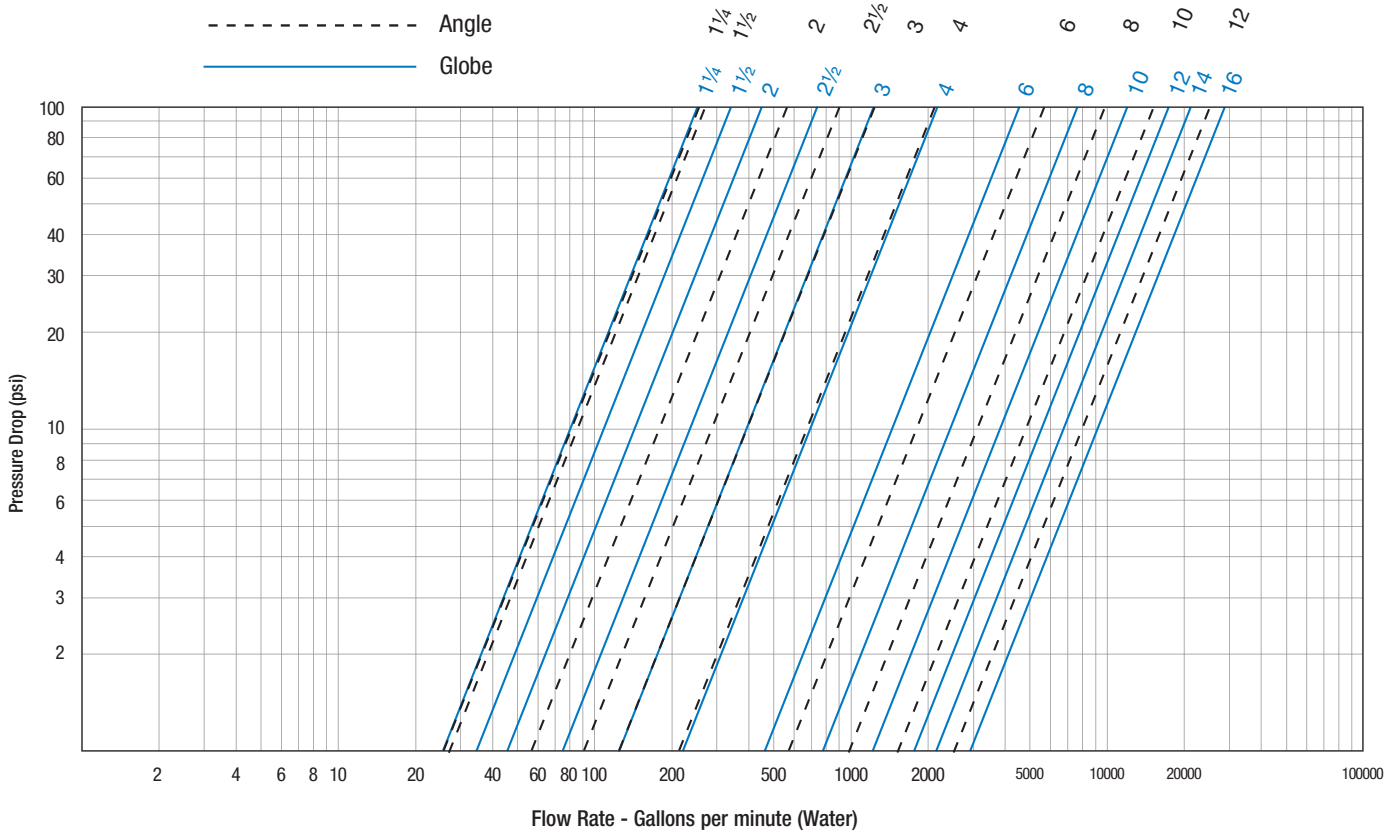

Valve Cover Chamber Capacity

Valve Size - Inches	1/4	1/2	2	2 1/2	3	4	6	8	10	12	14	16
fl.oz.	4	4	4	10	16	22	70					
U.S. Gal								1 1/4	2 1/2	4	6 1/2	9 1/2

Valve Travel

Valve Size - Inches	1/4	1/2	2	2 1/2	3	4	6	8	10	12	14	16
Travel - Inches	3/8	3/8	1/2	5/8	3/4	1	1 1/2	2	2 1/2	3	3 1/2	4

ACV Schematic - Series LFM115-7

M100 Basic Valve

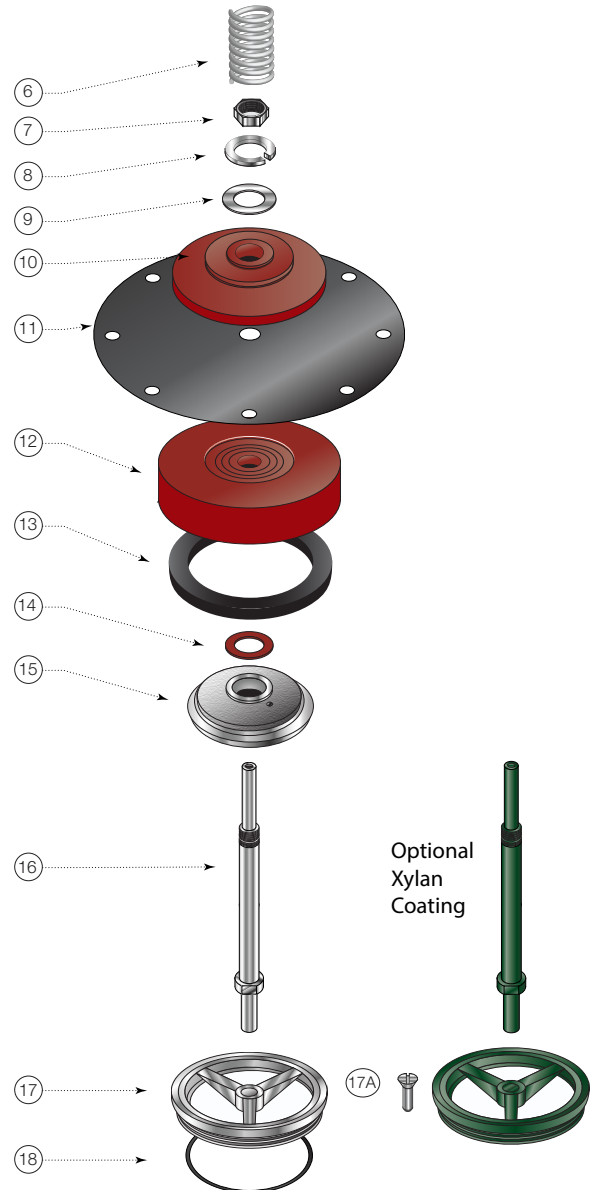
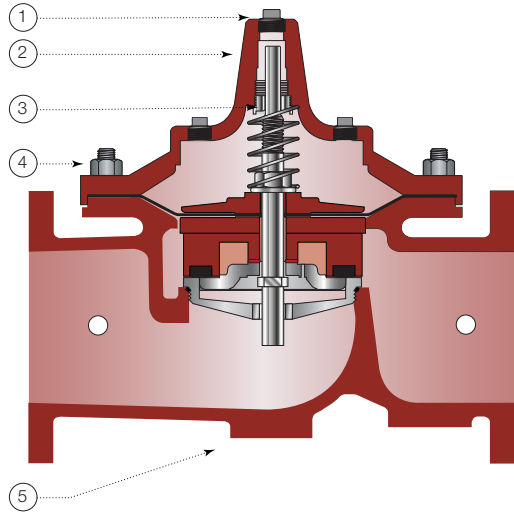

Item	Description	Material
1	Pipe Plug	Lead Free Brass
2	Cover	ASTM A536 65-45-12 Epoxy Coated Ductile Iron
3	Cover Bearing	ASTM A276 304 Stainless Steel
4	Stud with Cover Nut and Washer	ASTM A570 Gr.33 Zinc Plated Steel
5	Body	ASTM A536 65-45-12 Epoxy Coated Ductile Iron
6	Spring	ASTM A276 302 Stainless Steel
7	Stem Nut	ASTM A276 304 Stainless Steel
8	Lock Washer	ASTM A276 304 Stainless Steel
9	Stem Washer	ASTM A276 304 Stainless Steel
10	Diaphragm Washer	ASTM A536 65-45-12 Epoxy Coated Ductile Iron
11	Diaphragm*	Buna-N (Nitrile)
12	Disc Retainer	ASTM A536 65-45-12 Epoxy Coated Ductile Iron
13	Seat Disc*	Buna-N (Nitrile)
14	Spacer Washer* x5	NY300 Fiber*
15	Disc Guide	ASTM A743 CF8M (316) Stainless Steel
16	Shaft	ASTM A276 304 Stainless Steel
17	Seat Ring**	ASTM A743 CF8M (316) Stainless Steel
17A	Seat Screw** (8 " and Larger)	ASTM A276 304 Stainless Steel
18	Seat Gasket*	Buna-N (Nitrile)

* Contained in Main Valve Repair Kit

**Note: 6 inch and Smaller Valves, Seat Ring is threaded

NOTICE

Installation: If unit is installed in any orientation other than horizontal (cover up) OR extreme space constraints exist, consult customer service prior to or at the time of order.

ACV Schematic - Series LFM115-7

Dimensions

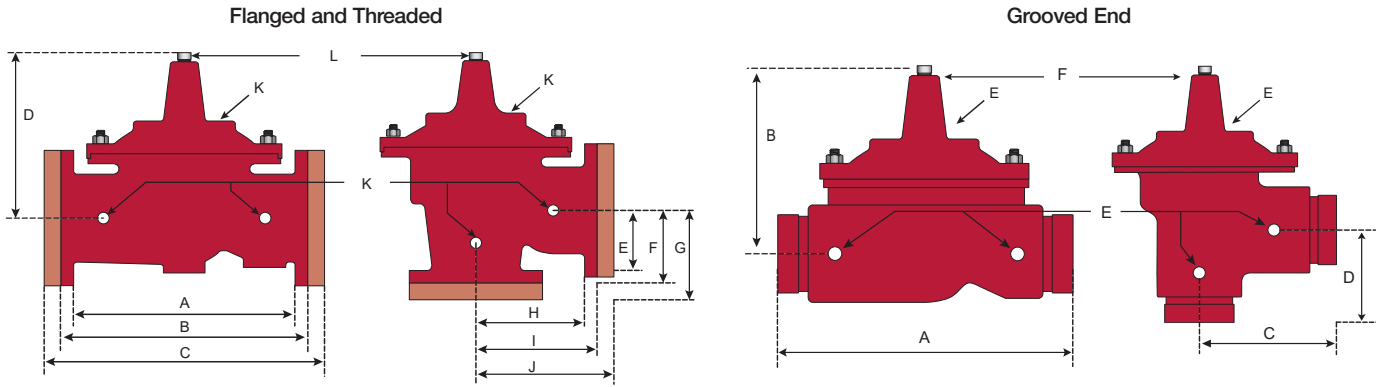

Flanged and Threaded Dimensions

Valve Size	Globe Thread		Globe 150#		Globe 300#		Cover To Center		Angle Thread		Angle 150#		Angle 300#		Angle Thread		Angle 150#		Angle 300#		Port Size NPT	Port Size NPT	Shipping Weights*	
	A	B	C	D	E	F	G	H	I	J	K	L												
in.	in.	mm	in.	mm	in.	mm	in.	mm	in.	mm	in.	mm	in.	mm	in.	mm	in.	mm	in.	mm	in.	in.	lbs.	kgs.
1¼	7¼	184					5½	140													¾	¼	20	9
1½	7¼	184	8½	216			5½	140	¾	83					1⅞	48					¾	¼	25	11
2	9⅞	238	9⅞	238	10	254	6¾	171	4¾	120	4¾	121	5	127	3¼	83	3¼	83	3½	89	¾	½	40	18
2½	11	279	11	279	11½	295	7½	191	5½	140	5½	140	5⅞	149	4	102	4	102	4⅞	110	½	½	65	29
3	12½	318	12	305	13¼	337	8¼	210	6¼	159	6	152	6⅞	162	4½	114	4	102	4⅞	111	½	½	95	43
4			15	381	15⅞	397	10⅞	270			7½	191	7⅞	200			5	127	5⅞	135	¾	¾	190	86
6			20	508	21	533	13	330			10	254	10½	267			6	152	6½	165	¾	¾	320	145
8			25⅜	645	26⅜	670	16	406			12¾	324	13¼	337			8	203	8½	216	1	1	650	295
10			29¾	756	31⅞	791	17	430			14⅞	378	15⅞	395			8⅞	219	9⅞	237	1	1	940	426
12			34	864	35½	902	20⅞	530			17	432	17¾	451			13¾	349	14½	368	1	1¼	1500	680
14			39	991	40½	1029	24¼	616													1	1½	1675	760
16			41⅜	1051	43½	1105	25¼	640													1	2	3100	1406

Grooved End Dimensions

Valve Size	Globe Grooved		Cover To Center		Angle Grooved		Angle Grooved		Port Size (npt)	Port Size (npt)	Shipping Weights*	
	A	B	C	D	E	F					lbs.	kgs.
in.	in.	mm	in.	mm	in.	mm	in.	mm	in.	in.		
1¼	8½	216	5½	140	4¼	108	¾	83	¾	¼	25	11
1½	8½	216	5½	140	4¼	108	¾	83	¾	¼	25	11
2	9	229	6½	165	4¾	121	¾	83	¾	½	40	18
2½	11	279	7½	191	5½	140	4	102	½	½	65	29
3	12½	318	8¼	210	6	152	4¼	108	½	½	95	43
4	15	381	10⅞	270	7½	191	5	127	¾	¾	190	86
6	20	508	13⅜	340					¾	¾	320	145
8	25⅜	645	16	406					1	1	650	295

LEAD FREE*

Model LFCP15

Pressure Reducing Pilot

Size: 3/8 " NPT

The Model LFCP-15 is a direct acting, diaphragm actuated Pilot that automatically reduces a higher upstream (inlet) pressure to a constant downstream (outlet) pressure. It is normally held open by the force of the adjustable spring setting above the diaphragm.

The Pilot modulates towards a closed position when outlet pressure exceeds the spring setpoint, lowering the delivery pressure. It modulates towards an open position when the outlet pressure falls below the spring setpoint, increasing the delivery pressure.

When a Model LFCP-15 is installed in the piping circuit of an Automatic Control Valve, its throttling action causes the Main Valve to throttle open or closed accordingly. Turning the adjustment screw clockwise raises the control setpoint, increasing main valve outlet pressure. Turning the adjustment screw counterclockwise lowers the control setpoint, decreasing Main Valve outlet pressure.

The Model LFCP-15 is equipped with one 3/8 " NPT inlet and two outlet ports for ease of installation. The unused outlet port may be plugged or used as a pressure gauge connection.



Model LFCP15

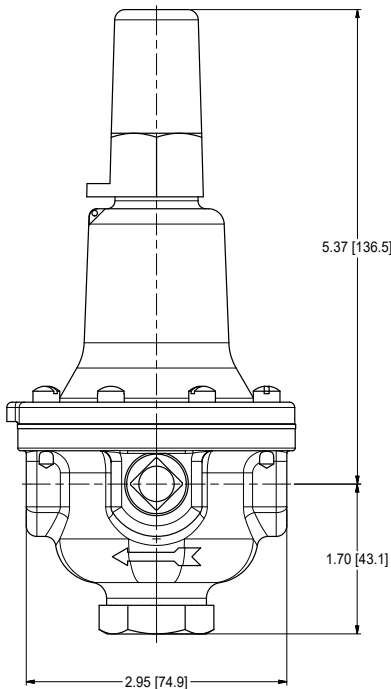

Specifications

Body Material:	Lead Free Copper Silicon Alloy CF8M (316) Stainless Steel (optional)
Seat:	316 Stainless Steel
Elastomers:	Buna-N (standard) Viton® (optional) EPDM (optional)
Inlet Pressure Rating:	400psi (27.6 bar) maximum
Adjustment Range:	30-300psi (2.1 - 20.7 bar) (standard) 2-30psi (0.15-2 bar) (optional)

Viton® is a registered trademark of DuPont Dow Elastomers.

*The wetted surface of this product contacted by consumable water contains less than 0.25% of lead by weight.

Model LFCP15

Pressure Reducing Pilot

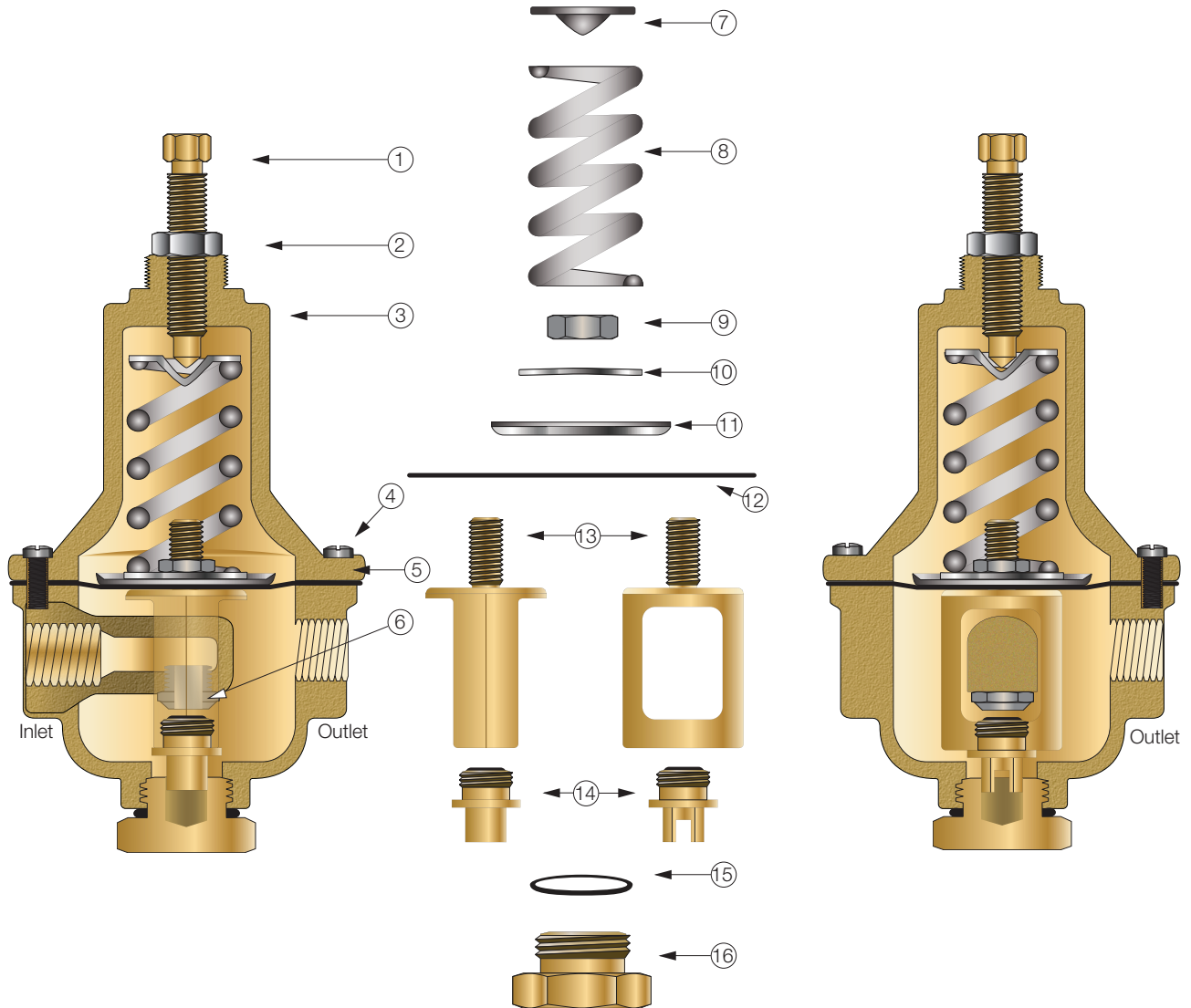

Item	Description
1	Adjusting Screw
2	Nut
3	Spring Housing
4	Cap Screw
5	Body
6	Seat
7	Spring Guide
8	Spring
9	Nut
10	Belleville Washer
11	Diaphragm Washer
12	Diaphragm*
13	Yoke
14	Disc and Retainer Assembly*
15	O-Ring*
16	Bottom Cap

* Included in Repair Kit

LEAD FREE*

Model LFPV20C

Pressure Relief, Sustaining or Backpressure Pilot

Size: 1/2 " NPT

The Model LFPV20C is a remote sensed direct acting, diaphragm actuated Pilot that is used on various configurations of Automatic Control Valves.

It is normally held closed by the force of the adjustable spring setting above the diaphragm. It modulates toward an open position when control pressure, exerting force below the diaphragm, exceeds the spring setpoint, and modulates toward a closed position when the control pressure falls below the spring setpoint. The LFPV20C senses control pressure through a tapped port below the diaphragm. The large diaphragm-to-seat ratio allows it to open and close within tight pressure tolerances, accurately positioning the Main Valve.

Turning the adjustment screw clockwise raises the control setpoint. Turning the adjustment screw counterclockwise lowers the control setpoint.

The LFPV20C is equipped with one 1/2 " NPT inlet and outlet port and a 1/4 " NPT side sensing port located on the power chamber. The 1/4 " side sensing port is used to monitor upstream or downstream pressure as required by specific valve function.



Model LFPV20C

Specifications

Body Material:	Lead Free Copper Silicon Alloy
Seat:	316 Stainless Steel
Elastomers:	Buna-N (standard) Viton® (optional) EPDM (optional)
Inlet Pressure Rating:	400psi (27.6 bar) maximum
Adjustment Rating:	20-200psi (1.4 - 13.8 bar) (standard) 0-30psi (0 - 2.1 bar) (optional) 100-300psi (6.9 - 20.7 bar) (optional) 200-450psi (13.8 - 31.0 bar) (optional)

Viton® is a registered trademark of DuPont Dow Elastomers.

*The wetted surface of this product contacted by consumable water contains less than 0.25% of lead by weight.

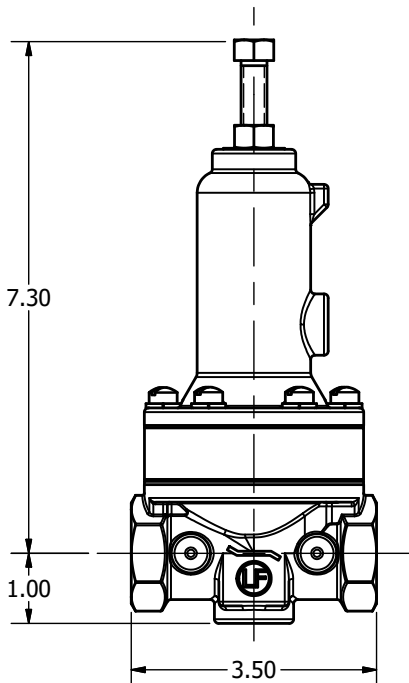

Model LFPV20C

Pressure Relief, Sustaining or Backpressure Pilot

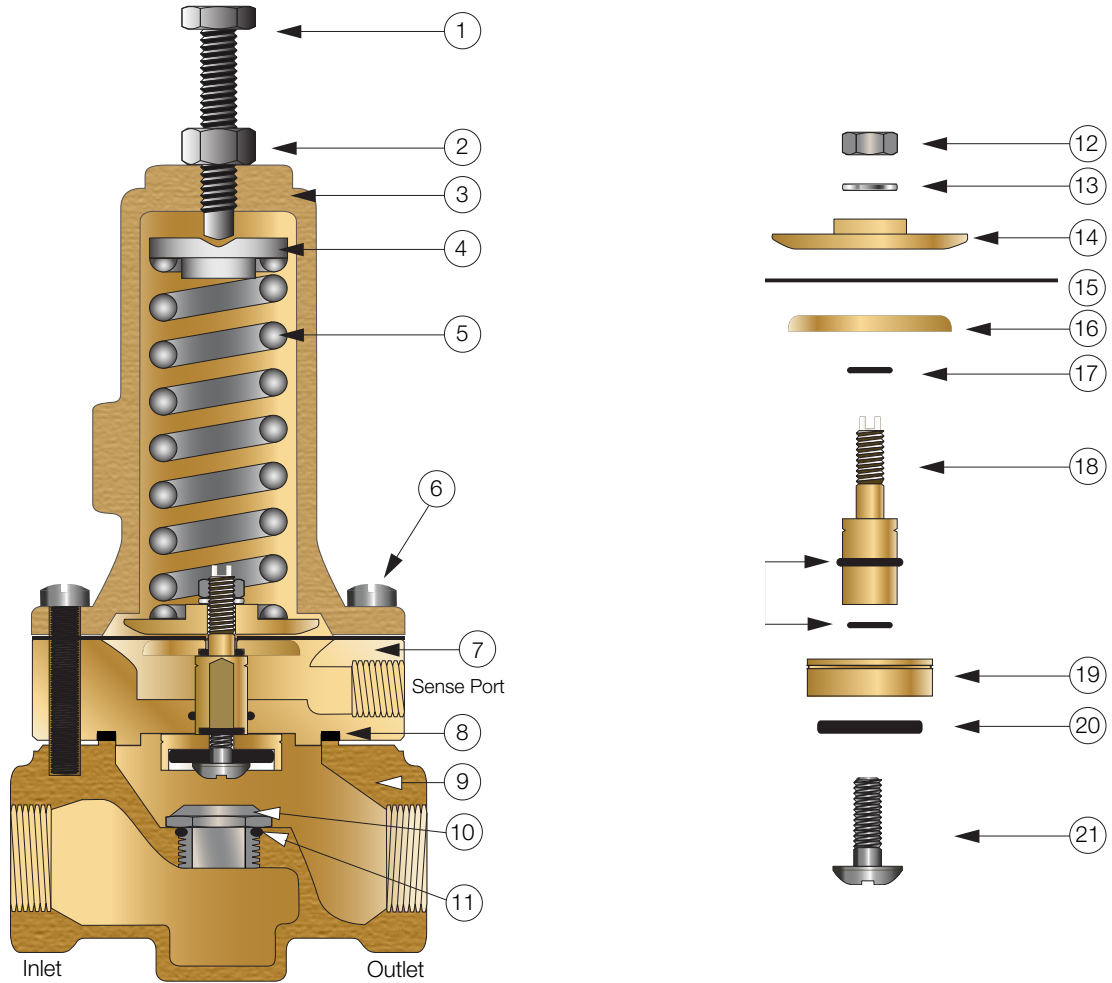

Item	Description
1	Adjusting Screw
2	Jam Nut
3	Spring Housing
4	Spring Guide
5	Spring
6	Cap Screw
7	Power Chamber
8	O-Ring*
9	Body
10	Seat
11	O-Ring*

Item	Description
12	Nut
13	Lockwasher
14	Diaphragm Washer
15	Diaphragm*
16	Diaphragm Washer
17	O-Ring*
18	Stem
19	Retainer
20	Rubber Disc*
21	Screw

*Included in Repair Kit

LEAD FREE*

Model BV

Ball Valve

Size: 1/4 " - 1 " NPT

Model BV Ball Valves are used in pilot lines to provide a positive shutoff in any override or maintenance situation for simple trouble shooting. This 2-piece, full port valve features: bottom loaded stems, PTFE seats and packing.

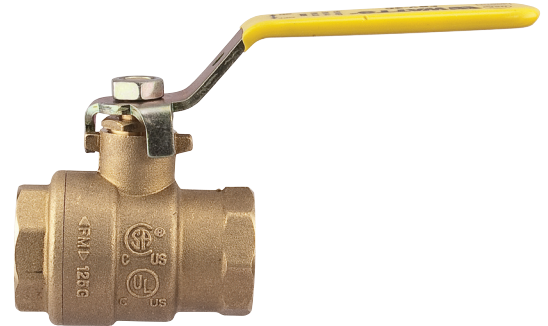

Lead Free Ball Valve

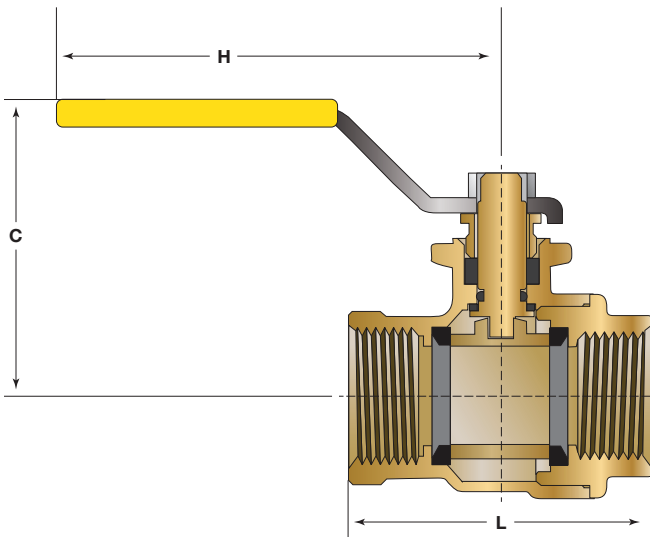

Size	Dimensions						Weight	
	C		H		L		lbs.	kg.
in.	in.	mm	in.	mm	in.	mm		
1/4	1 13/16	46	3 7/16	87	1 3/4	45	0.4	0.2
3/8	1 13/16	46	3 7/16	87	1 3/4	45	0.4	0.2
1/2	1 13/16	46	3 7/16	87	1 13/16	50	0.4	0.2
3/4	2 1/4	57	4	101	2 5/16	59	0.8	0.3

Specifications

Standard Material: Copper Silicon Alloy Body and Adaptor
Chrome Plated Ball

Optional Material: Stainless Steel Housing, Body and Adaptor
Stainless Steel Ball

Pressure Rating: 600psi (41 bar) Non Shock

Temp Rating: -40°F - 400°F

*The wetted surface of this product contacted by consumable water contains less than 0.25% of lead by weight.

LEAD FREE*

Model LF60

Flo-Clean Strainer

Size: 1/4 " - 3/4 " NPT

Model LF60 Flo-Clean Strainers are used to filter the fluid passing through the pilot circuit, and provide protection to pilot circuit speed controls and pilots. It is installed in the inlet body port of the Main Valve, exposing the strainer element to main line flow. The currents and flow across the screen create a self-scouring effect, cleaning the filter element.

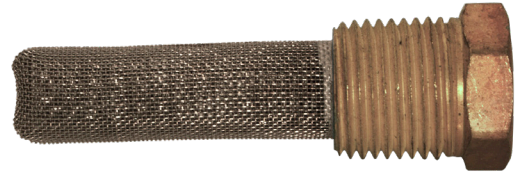

Model LF60

Valve inlet with Filter installed

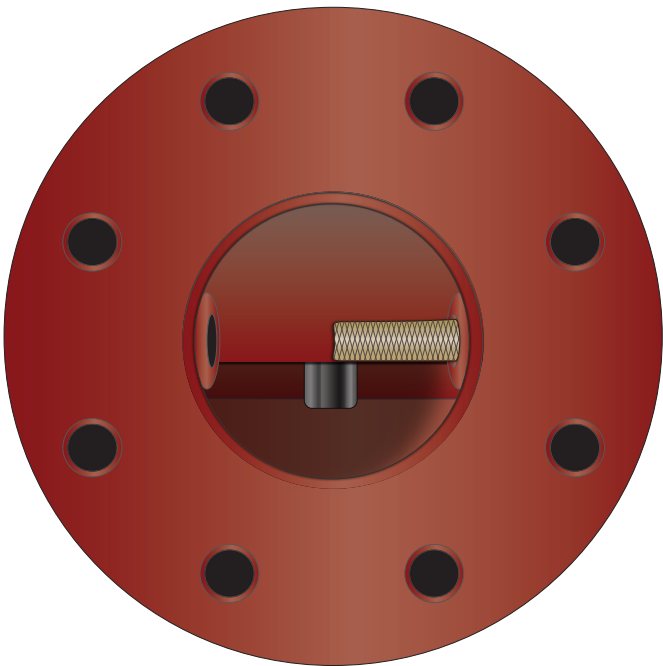

Specifications

- Body Material:** Lead Free Brass (standard)
Stainless Steel (optional)
- Pressure Rating:** 400psi (27.6 bar)
- Filter Element:** Monel
- Screen Mesh:** 40 Mesh (standard)

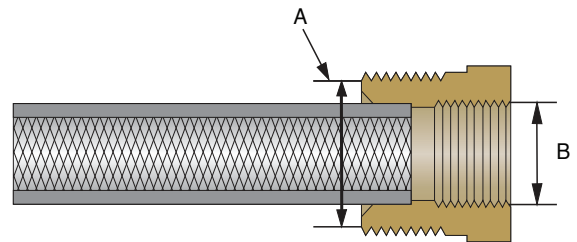

A	B
Male Pipe Thread	Female Pipe Thread
in.	in.
1/4	1/8
3/8	1/4
1/2	3/8

*The wetted surface of this product contacted by consumable water contains less than 0.25% of lead by weight.

LEAD FREE*

Model LF60-1

Y-Pattern Strainer

Size: 1/4 " - 3/4 " NPT

Model LF60-1 Y-Pattern Strainers are used to filter the fluid passing through the pilot circuit, and provide protection to pilot circuit speed controls and pilots. The filter element can be accessed for cleaning by removing the clean-out cap, or may be cleaned by installing an optional "blow-down" ball valve.



Model LF60-1

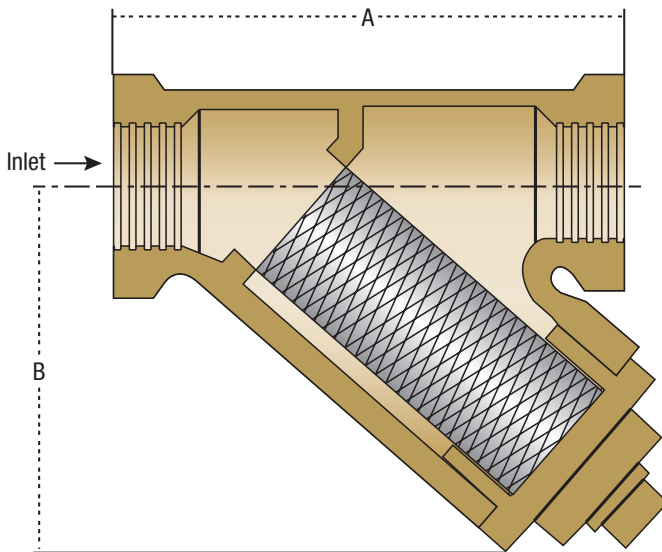

Specifications

- Body Material:** Lead Free Copper Silicon Alloy
CF8M (316) Stainless Steel (optional)
- Retainer Cap:** Lead Free Copper Silicon Alloy
- Cap Gasket:** EPDM
- Pressure Rating:** 400psi (27.6 bar)
- Filter Element:** 304 Stainless Steel
- Mesh Options:** 60 Mesh (standard)
100 Mesh (optional)

Dimensions

SIZE	DIMENSIONS				WEIGHT	
	A		B		lbs.	kgs.
in.	in	mm	in	mm		
1/4	2 1/16	68	1 1/16	43	1.7	0.77
3/8	2 1/16	68	1 1/16	43	1.7	0.77
1/2	3	76	2	51	1.7	0.77
3/4	3 5/16	84	2 5/16	59	1.7	0.77

*The wetted surface of this product contacted by consumable water contains less than 0.25% of lead by weight.

LEAD FREE*

Model LFFC

Flow Control

Size: 1/2 " NPT

A Flow Control is an adjustable device used for tuning valve performance. It can be installed to either control the opening or closing the speed of the automatic control main valve. When the flow is in the direction of the needle the flow control is an adjustable restriction. In the free flow direction the seat moves out of the flow path to all unrestricted flow.

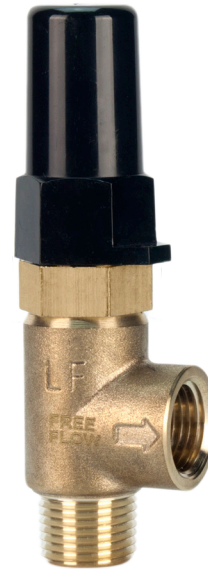

Model LFFC

CLOSED
Fluid Speed
Controlled by Needle

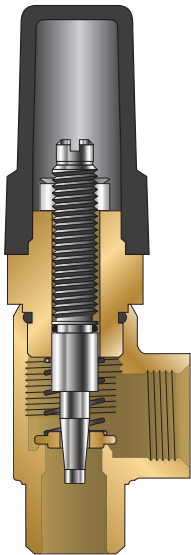

OPEN
Free Flow
Seat Full Open

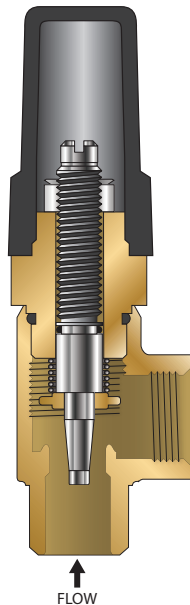

Specifications

Size:	1/2 " NPT
Body Material:	Lead Free Brass Stainless Steel (optional)
Seat:	Lead Free Brass
Needle:	Stainless Steel (304)
Elastomers:	Buna-N (standard)

*The wetted surface of this product contacted by consumable water contains less than 0.25% of lead by weight.

LEAD FREE*

Model 50 Position Indicator

When specified as an option on a Control Valve, the Model 50 Position Indicator is installed in the topmost cover port of the Main Valve and allows for visual indication of valve position. The Model 50 is also very useful during valve start-up and troubleshooting procedures.

A stainless steel indicating rod threads into the tapped portion of the Main Valve stem and moves inside of a cylindrical Pyrex sight tube. The indicating rod travels up and down, following Main Valve stem movement. The housing protects the sight tube and indicating rod, and allows visibility on two sides. The screw driver operated test cock installed on the top of the Model 50 housing provides a controlled method of removal of air from the cover chamber during start-up or troubleshooting of the Main Valve.



Model LF50

Dimensions

Valve Size (in)	Dimension (in)
1¼ - 1½	7¾
2	4¾
2½	4¾
3	4¾
4	5
6	5
8	5¾
10	5¾
12	7¼
14	7¼
16	7¼
18*	7¼
20*	7¼
24*	7¼

*Reduced Port



Specifications

Standard Material:

Stainless Steel Housing and Body
Stainless Steel Indicating Rod
Lead Free Test Cock
Pyrex Sight Tube

Optional Material:

Stainless Steel Test Cock

Pressure Rating:

400psi (27.6 bar)

*The wetted surface of this product contacted by consumable water contains less than 0.25% of lead by weight.

Model 50

Position Indicator

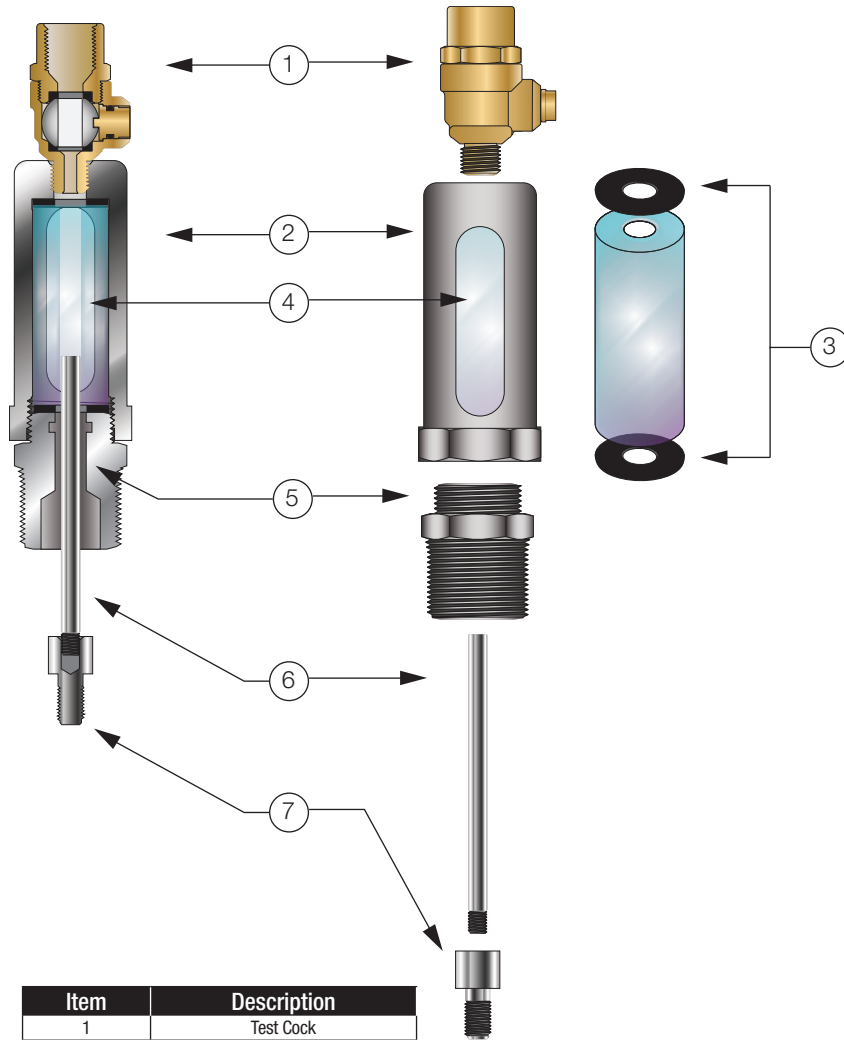

Item	Description
1	Test Cock
2	Housing
3	Gasket
4	Pyrex Sight Tube
5	Body
6	Indicating Rod
7	Stem Adaptor (8 " or Larger)

LEAD FREE*

Model 51

Single Limit Switch

The Model 51 Single Limit Switch provides visual indication of valve position, as well as remote electrical indication of "valve open" or "valve closed". The single pole double throw Micro-Switch can be connected to open or close an electrical circuit when the valve opens or closes.

The adjustable collar is normally set to contact the trip arm when the main valve is closed. The collar can be positioned on the stem by loosening the set-screw to actuate the switch at the desired point of valve travel.

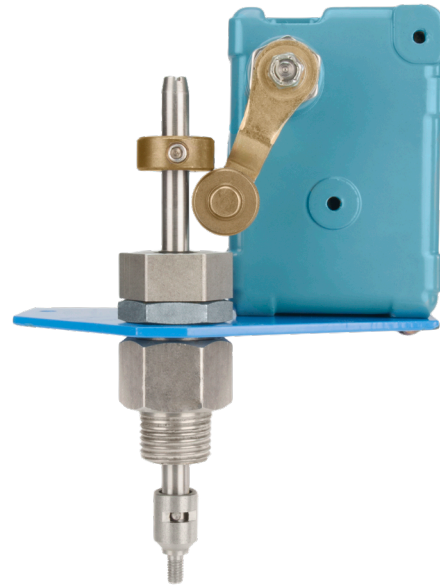

Model LF51

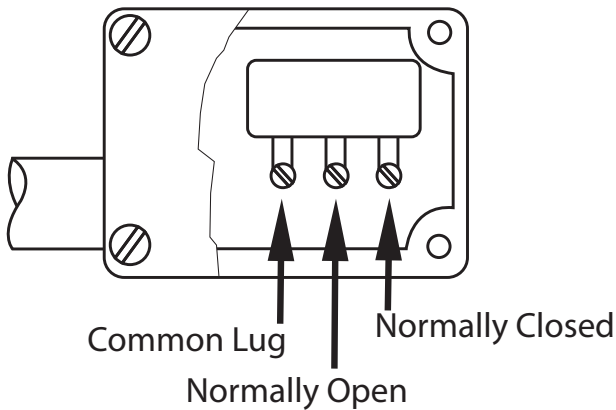

Single Pole Double Throw Switch

Specifications

Body Material: Stainless Steel

Elastomers: Buna-N (standard)
EPDM (optional)
Viton® (optional)

Enclosure: NEMA 1, 3, 4 and 13 General Purpose (standard)
NEMA 1,7 and 9 Explosion Proof (optional)

Electrical: Form C SPDT Switch
15 amp. 125, 250 or 480 VAC
½ amp. 125 VDC
¼ amp. 250 VDC
½" Conduit Connection

Viton® is a registered trademark of DuPont Dow Elastomers.

*The wetted surface of this product contacted by consumable water contains less than 0.25% of lead by weight.

Model 51

Single Limit Switch

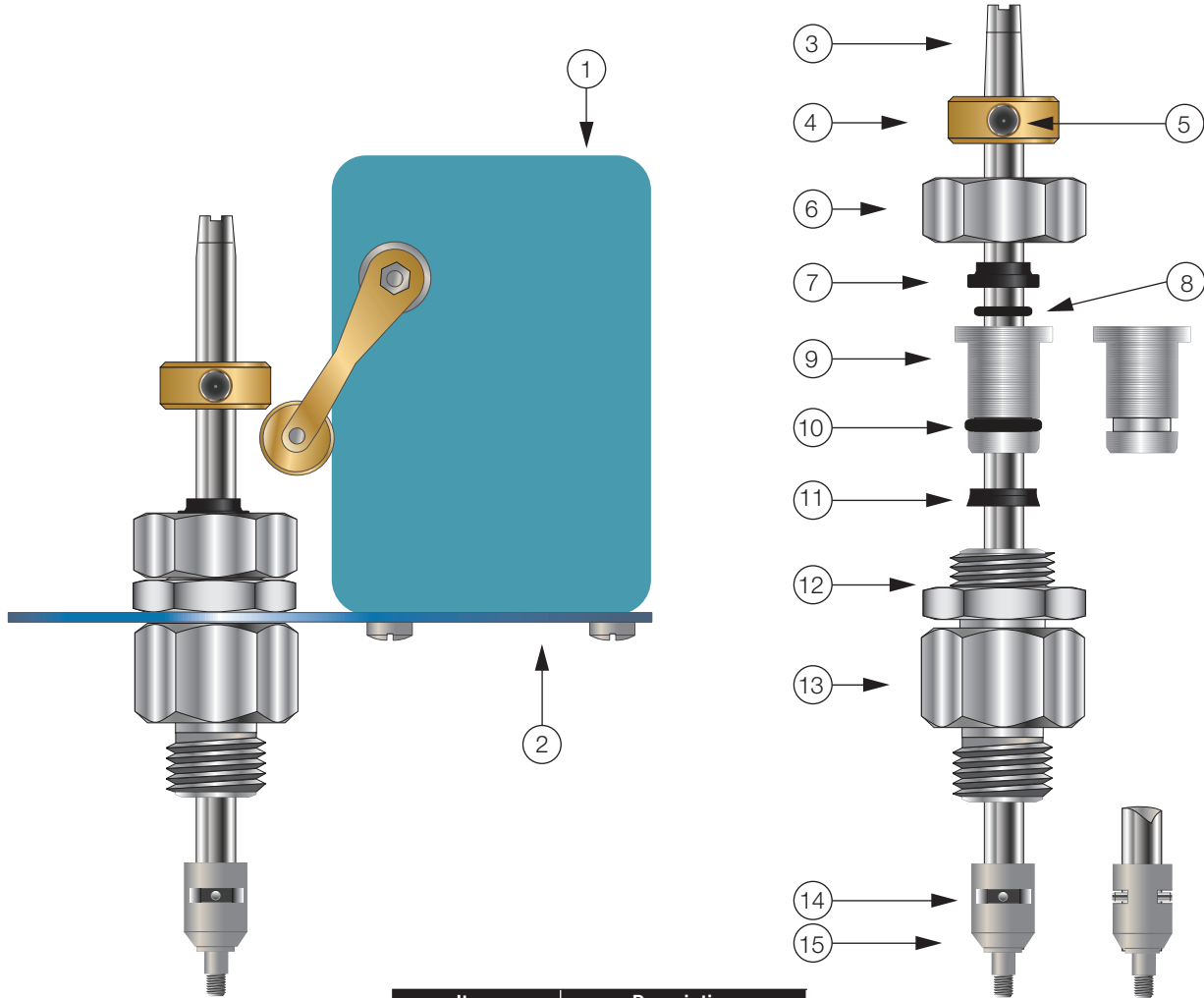

Item	Description
1	Limit Switch
2	Bracket
3	Stem
4	Trip collar
5	Set Screw
6	Cap
7	Wiper Ring*
8	O-Ring*
9	Guide
10	O-Ring*
11	Polypak*
12	Locknut
13	Body
14	Pin
15	Coupling

*Included in Repair Kit



USA: T: (978) 689-6066 • F: (978) 975-8350 • Watts.com
 Canada: T: (888) 208-8927 • F: (905) 332-7068 • Watts.ca
 Latin America: T: (52) 55-4122-0138 • Watts.com