

59MN7B Infinity® Modulating 4- Way Multipoise Condensing Gas Furnace

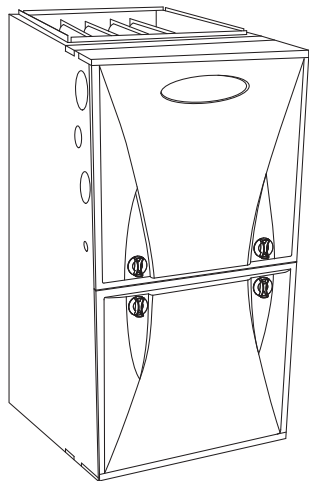

Product Data



A11263

The 59MN7B Multipoise Variable-Capacity Condensing Gas Furnace features the modulating Infinity® System. The innovative modulating gas valve is at the heart of this furnace's quiet operation, along with the variable-speed Infinity ECM blower motor and variable-speed inducer motor. This furnace also provides 3.5 times tighter temperature control than single stage furnaces. With an Annual Fuel Utilization Efficiency (AFUE) up to 98.5%, this Infinity gas furnace provides exceptional savings over standard furnaces as well. This Infinity Gas Furnace also features 4-way multipoise installation flexibility. The 59MN7B can be vented as a direct vent/two-pipe furnace or as an optional ventilated combustion air application. A Carrier Infinity® Control and an Infinity® Air Conditioner or Heat Pump can be used to form a complete Infinity System. Low NOx units are designed for California installations and meet 40 ng/J NOx emissions. Can be installed in air quality management districts with a 40 ng/J NOx emissions requirement. All sizes are design certified in Canada. This furnace is not designed for use in recreation vehicles, manufactured (mobile) homes or outdoors.

STANDARD FEATURES

- Our quietest furnace. Compare for yourself at HVACpartners.com.
- All sizes meet ENERGY STAR® Version 4.0 criteria for gas furnaces: 95%+AFUE
- Supports single- and multiple-zone Infinity® systems.
- Ideal height 35" (889 mm) cabinet: short enough for taller coils, but still allows enough room for service.
- Infinity® Features—match with the Infinity® Control for Infinity® System benefits
- Integral part of the Ideal Humidity System® Technology.
- Silicon Nitride Power Heat™ Hot Surface Igniter.
- SmartEvap™ technology helps control humidity levels in the home when used with a compatible humidity control system.
- ComfortFan™ technology allows control of continuous fan speed from a compatible thermostat.
- External Media Filter Cabinet included.
- 4-way multipoise design for upflow, downflow or horizontal installations, with unique vent elbow and optional through-the-cabinet downflow venting capability.
- Variable-Speed blower and inducer motors, modulating gas valve.
- Self-diagnostics and extended diagnostic data through the Advanced Product Monitor (APM) accessory or Infinity® User Interface.
- Adjustable blower speed for cooling, continuous fan, and dehumidification.
- Aluminized-steel primary heat exchanger.
- Stainless-steel condensing secondary heat exchanger.
- Propane convertible (See Accessory list).
- Factory-configured ready for upflow applications.
- Fully-insulated casing including blower section.
- Convenient Air Purifier and Humidifier connections.
- Direct-vent/sealed combustion or ventilated combustion air venting.
- Installation flexibility: sidewall or vertical vent.
- Residential installations may be eligible for consumer financing through the Retail Credit Program.
- Cabinet air leakage less than 2.0% at 1.0 in. W.C. and cabinet air leakage less than 1.4% at 0.5 in. W.C. when tested in accordance with ASHRAE standard 193.



Use of the AHRI Certified TM Mark indicates a manufacturer's participation in the program. For verification of certification for individual products, go to www.ahridirectory.org.



SAP ORDERING NO.	CASING DIMENSIONS (IN.)			RATED HEATING OUTPUT† (BTUH)		AFUE		ENERGY STAR®	HEATING AIRFLOW			COOLING CFM @ 0.5 ESP	MOTOR HP (VARIABLE SPEED)	MEDIA CABINET SUPPLIED (IN.)
	H	D	W	Maximum	Minimum	Upflow/ Horizontal	Downflow		CFM‡	CFM	Rated Heating ESP			
									(Minimum Heating)	(Maximum Heating)	@ Maximum			
59MN7B060C17--14	35	29.5	17.5	59,000	24,000	97.4%	95.0%	YES	415	1075	0.12	510 - 1335	1/2	16
59MN7B060C21--20	35	29.5	21.0	60,000	24,000	98.5%	96.7%	YES	555	1085	0.12	510 - 1905	1	20
59MN7B080C17--14	35	29.5	17.5	78,000	31,000	97.4%	95.0%	YES	620	1500	0.15	490 - 1375	1/2	16
59MN7B080C21--20	35	29.5	21.0	78,000	31,000	97.2%	95.0%	YES	620	1345	0.15	750 - 1945	1	20
59MN7B100C21--22	35	29.5	21.0	98,000	39,000	97.3%	95.0%	YES	725	1575	0.20	715 - 2160	1	20
59MN7B120C24--22	35	29.5	24.5	117,000	47,000	97.2%	95.0%	YES	900	1820	0.20	885 - 2185	1	24

†Capacity in accordance with DOE test procedures. Ratings are position dependent. See rating plate.

‡Minimum heat CFM when low-heat rise adjustment switch (SW 1 - 3) and comfort/efficiency adjustment switch (SW1 - 4) on control center are OFF.
ESP - External Static Pressure

FEATURES AND BENEFITS

Greenspeed™ Intelligence — Adaptable-speed technology paired with Infinity® intelligence, our new technology takes into account a home owner's complete comfort. It provides precise comfort by adjusting the heating demands of the home. This translates into reduced energy use and reduced temperature swings. Integrating luxury-level comfort control into a home so smoothly and quietly, you'll forget it's there.

Fully Modulating Gas Valve — When paired with the Infinity® control, this furnace improves comfort by adjusting heating output in 1% increments from 40% to 100% capacity to meet the heating needs of the home. Precision begins with a stepper motor to adjust manifold pressures. Stepper motors are used in electronic devices, such as computer disc drives, which require precise mechanical positioning. The precision of the stepper motor, combined with our unique two-point calibration, allows the modulating furnace to accurately control and directly deliver the right amount of gas to the burners every time.

Ideal Humidity System® Technology — This system actively controls both temperature and humidity in the home to provide the best comfort all year long. Other systems depend on heating or cooling demand to manage the moisture in the air but the Ideal Humidity system gives the homeowner the right amount of humidity day and night, even in mild weather. No other manufacturer can do this! Ideal Humidity saves energy, too. By keeping humidity under control, the homeowner can set their thermostat lower to stay comfortable and save energy.

SmartEvap™ Technology — When paired with a compatible thermostat, this dehumidification feature overrides the cooling blower off-delay when there is a call for dehumidification. By deactivating the blower off-delay, SmartEvap technology prevents condensate that remains on the coil after a dehumidification cycle from re-humidifying throughout the home. This results in reduced humidity and a more comfortable indoor environment for the homeowner.

Unlike competitive systems, SmartEvap technology only overrides the cooling when humidity control is needed. Once humidity is back in control, SmartEvap re-enables the energy-saving cooling blower off-delay.

ComfortFan™ Technology — Sometimes the constant fan setting on a standard furnace system can actually reduce homeowner comfort by providing too much or too little air! Comfort Fan technology improves comfort all year long by allowing the homeowner to select the continuous fan speed of their choice using a compatible thermostat.

Power Heat™ Igniter — Carrier's unique SiN igniter is not only physically robust but it is also electrically robust. It is capable of running at line voltage and does not require complex voltage regulators as do other brands. This unique feature further enhances the gas furnace reliability and continues Carrier's tradition of technology leadership and innovation in providing a reliable and durable product.

Full-Featured, Communicating, Variable Speed Motors — Our ECMs (Electronically Commutated Motors) provide variable-speed operation to optimize comfort levels in the home year round; features such as passive/active dehumidification, ramping profiles, constant air flow and quiet operation. They can provide cooling match enhancements to increase the effective SEER of select Carrier air conditioner or heat pump systems, and feature the highest efficiency of all indoor fan motors.

Reliable Heat Exchanger Design — The aluminized steel, clam shell primary heat exchanger was re-engineered to achieve greater efficiency out of a smaller size. The first two passes of the heat exchanger are based on the current 80% product, a design with

more than ten years of field-proven performance and success. These innovations, paired with the continuation of a crimped, no-weld seam create an efficient, robust design for this essential component.

The condensing heat exchanger, a stainless steel fin and tube design, is positioned in the furnace to extract additional heat. Stainless steel coupling box componentry between heat exchangers has exceptional corrosion resistance in both natural gas and propane applications.

Media Filter Cabinet — Enhanced indoor air quality in the home is made easier with our media filter cabinet—a standard accessory on all deluxe furnaces. When installed as a part of the system, this cabinet allows for easy and convenient addition of a Carrier high efficiency air filter.

4-Way Multipoise Design — One model for all applications — there is no need to stock special downflow or horizontal models when one unit will do it all. The heat exchanger design allows these units to achieve the certified AFUE in all positions.

Direct Venting or Optional Ventilated Combustion Air — This furnace can be installed as a 2-pipe (Direct Vent) furnace or as an optional ventilated combustion air application. This provides added flexibility to meet diverse installation needs.

Sealed Combustion System — This furnace brings in combustion air from outside the furnace, which results in especially quiet operation. By sealing the entire combustion vestibule, the entire furnace can be made quieter, not just the burners.

Insulated Casing — Foil-faced insulation in the heat exchanger section of the casing minimizes heat loss. The acoustical insulation in the blower compartment reduces air and motor noise for quiet operation.

Monopoint Burners — The burners are specially designed and finely tuned for smooth, quiet combustion and economical operation.

Bottom Closure — Factory-installed for side return; easily removable for bottom return. The multi-use bottom closure can also serve for roll-out protection in horizontal applications, and act as the bottom closure for the optional return air base accessory.

Blower Access Panel Switch — Automatically shuts off 115-v power to furnace whenever blower access panel is opened.

Quality Registration — Our furnaces are engineered and manufactured under an ISO 9001 registered quality system.

Certifications — This furnace is CSA (AGA and CGA) design certified for use with natural and propane gases. The furnace is factory-shipped for use with natural gas. A CSA listed gas conversion kit is required to convert furnace for use with propane gas. The efficiency is AHRI efficiency rating certified. This furnace meets 40ng/J Air Quality Management District emission requirements.

SPECIFICATIONS

The furnace should be sized to provide 100 percent of the design heating load requirement plus any margin that occurs because of furnace model size capacity increments. None of the furnace model sizes can be used if the heating load is 20,000 BTU or lower. Use Air Conditioning Contractors of America (Manual J and S); American Society of Heating, Refrigerating, and Air-Conditioning Engineers; or other approved engineering method to calculate heating load estimates and select the furnace. Excessive oversizing of the furnace may cause the furnace and/or vent to fail prematurely, customer discomfort and/or vent freezing. Failure to follow these guidelines is considered faulty installation and/or misapplication of the furnace; and resulting failure, damage, or repairs may impact warranty coverage.

Heating Capacity and Efficiency			060-14	060-20	080-14	080-20	100-22	120-22	
Input	Maximum Heat	(BTUH)	60,000	60,600	80,000	80,000	100,000	120,000	
	Intermediate Heat	(BTUH)	39,000	39,000	52,000	52,000	65,000	78,000	
	Minimum Heat	(BTUH)	24,000	24,000	32,000	32,000	40,000	48,000	
Output	Maximum Heat	(BTUH)	59,000	60,000	78,000	78,000	98,000	117,000	
	Intermediate Heat	(BTUH)	38,000	39,000	51,000	51,000	64,000	76,000	
	Minimum Heat	(BTUH)	24,000	24,000	31,000	31,000	39,000	47,000	
Certified Temperature Rise Range °F (°C)		Maximum Heat	35 - 65 (19 - 36)	35 - 65 (19 - 36)	40 - 70 (22 - 39)	40 - 70 (22 - 39)	45 - 75 (25 - 42)	45 - 75 (25 - 42)	
		Intermediate Heat	50 - 80 (28 - 44)	40 - 70 (22 - 39)	50 - 80 (28 - 44)	50 - 80 (28 - 44)	50 - 80 (28 - 44)	50 - 80 (28 - 44)	
		Minimum Heat	35 - 65 (19 - 36)	25 - 55 (14-31)	35 - 65 (19 - 36)	35 - 65 (19 - 36)	35 - 65 (19 - 36)	35 - 65 (19 - 36)	
Airflow Capacity and Blower Data									
Rated External Static Pressure (in. w.c.)		Heating	0.12	0.12	0.15	0.15	0.20	0.20	
		Cooling	0.5	0.5	0.5	0.5	0.5	0.5	
Airflow Delivery @ Rated ESP (CFM)		Maximum Heat	1075	1080	1500	1345	1575	1820	
		Intermediate Heat	530	690	750	795	955	1100	
		Minimum Heat	415	555	620	595	745	900	
		Cooling	1335	1905	1375	1945	2160	2185	
Cooling Capacity (tons)		400 CFM/ton	3	4.5	3.5	4.5	5.5	5.5	
		350 CFM/ton	3.5	5.5	4	5.5	6	6	
Direct-Drive Motor Type			Electronically Commutated Motor (ECM)						
Direct-Drive Motor HP			1/2	1	1/2	1	1	1	
Motor Full Load Amps			7.7	12.8	7.7	12.8	12.8	12.8	
RPM Range			300 - 1300						
Speed Selections			Variable (Communicating)						
Blower Wheel Dia x Width		in.	11 x 8	11 x 10	11 x 8	11 x 10	11 x 10	11 x 11	
Air Filtration System			Factory Supplied Media Cabinet Field Supplied Filter						
Filter Used for Certified Watt Data*			KGAWF**06UFR						
Electrical Data									
Input Voltage		Volts-Hertz-Phase	115-60-1						
Operating Voltage Range		Min-Max	104 -127						
Maximum Input Amps		Amps	9.0	14.1	9.0	14.1	14.1	14.1	
Unit Ampacity		Amps	12.0	18.4	12.0	18.4	18.4	18.4	
Minimum Wire Size		AWG	14	12	14	12	12	12	
Maximum Wire Length @ Minimum Wire Size		Feet	30	31	30	31	31	31	
		(M)	(9.4)	(9.5)	(9.4)	(9.5)	(9.5)	(9.5)	
Maximum Fuse/Ckt Bkr (Time-Delay Type Recommended)		Amps	15	20	15	20	20	20	
Transformer Capacity (24vac output)			40 VA						
External Control Power Available		Heating	27.9 VA						
		Cooling	34.6 VA						
Controls									
Gas Connection Size			1/2" - NPT						
Burners (Monoport)			3	3	4	4	5	6	
Gas Valve (Redundant)		Manufacturer	White Rogers						
Minimum Inlet Gas pressure (in. wc)			4.5						
Maximum Inlet Gas pressure (in. wc)			13.6						
Manufactured (Mobile) Home Kit			<i>not approved for MH use</i>						
Twinning Kit			<i>not approved for twinning</i>						
Ignition Device			Silicon Nitride						
Heating Blower Control (Heating Off-Delay)			Adjustable: 90, 120, 150, 180 seconds						
Cooling Blower Control (Time Delay Relay)			90 seconds						
Communication System			Infinity®; Infinity® Zoning						
Thermostat Connections			R, W/W1, W2 Y/Y2, Y1, G, Com 24V, DHUM						
Accessory Connections			EAC (115vac); HUM (24vac); 1-stg AC (via Y/Y2)						

* See Accessory List for part numbers available.

MODEL NUMBER NOMENCLATURE

1, 2 Gas Furnace 58	3 Heating Stages M	4 Tier N	5 Min. AFUE/NOx 7	6 Major Series B	7, 8, 9 Heating Input 060	10 Motor Type E	11, 12 Width 17	13 Voltage (1-phase) 1	14 Minor Series 1	15, 16 Airflow 16
58 = 80% Non-Condensing 58 = 90%+ Condensing	M = Modulating S = Single Stage T = Two Stage	B = Base C = Comfort E = Export N = Infinity P = Performance U = Ultra Low Nox	0 = Std. NOx 80% 1 = 80% Low Nox --- 2 = 92% 5 = 95% 6 = 98% 7 = 97% 8 = 98%	A B C ---	026 = 26,000 BTU 040 = 40,000 BTU 060 = 60,000 BTU --- 155 = 155,000 BTU	C = Comm. Variable-Speed Constant Airflow (VCA) ECM E = Fixed-Speeds Constant Torque (FCT) ECM V = Variable-Speed Constant Torque (VCT) ECM	14 - 14.2" 17 - 17.5" 21 - 21.0" 24 - 24.5"	1 = 110V/60Hz 2 = 230V/50Hz	1 2 3 ---	08 = 800 CFM 10 = 1000 CFM 12 = 1200 CFM 14 = 1400 CFM 16 = 1600 CFM 20 = 2000 CFM 22 = 2200 CFM

A190041

For California Residents:

For installation in SCAQMD only: This furnace does not meet the SCAQMD Rule 1111 14 ng/J NOx emission limit, and thus is subject to a mitigation fee of up to \$450. This furnace is not eligible for the Clean Air Furnace Rebate Program: www.CleanAirFurnaceRebate.com

FURNACE COMPONENTS

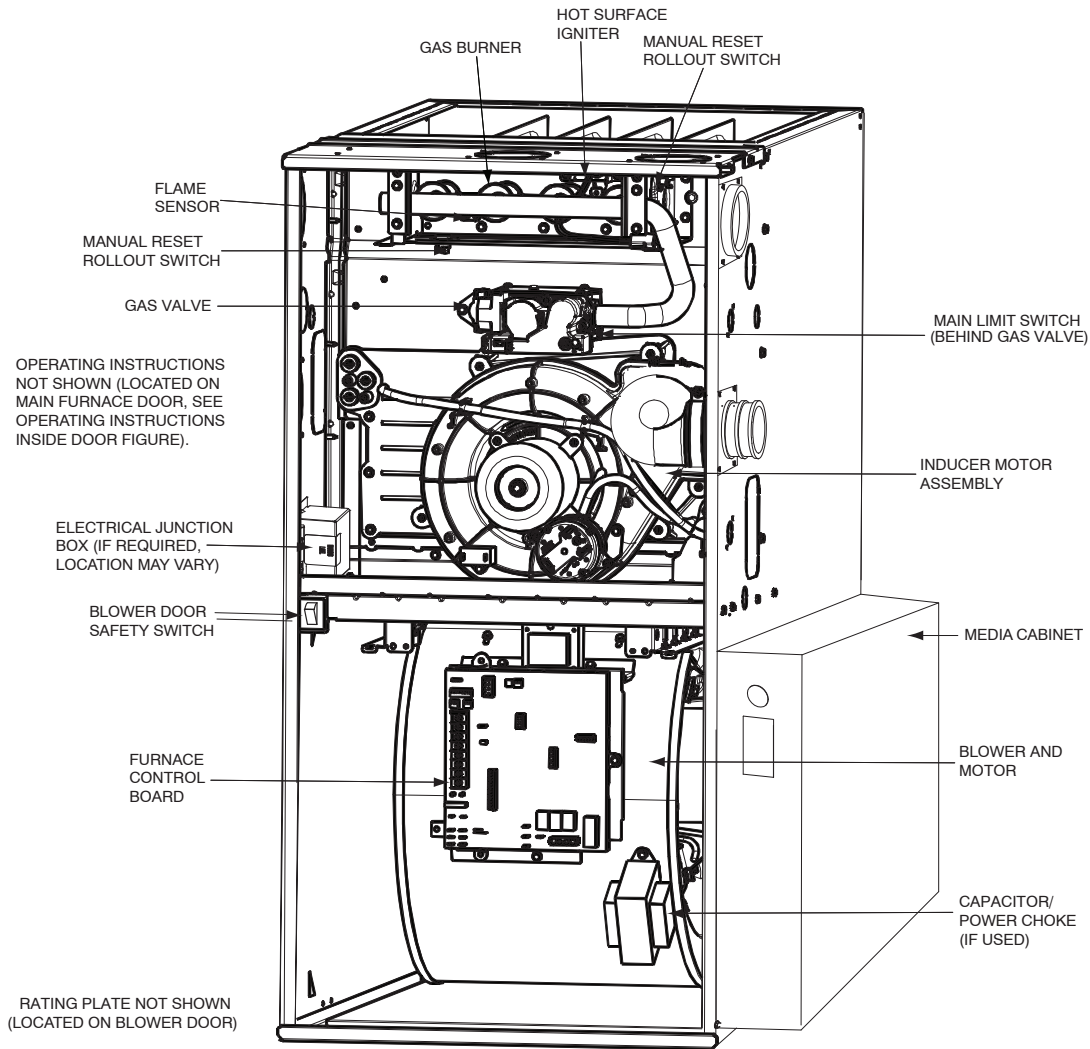

REPRESENTATIVE DRAWING ONLY, SOME MODELS MAY VARY IN APPEARANCE.

A170154

ACCESSORIES

DESCRIPTION	PART NUMBER	060-14	060-20	080-14	080-20	100-22	120-22
Venting Accessories							
Vent Kit - Through the Cabinet	KGADC0101BVC	●	●	●	●	●	●
Vent Terminal - Concentric - 2" (51 mm)	KGAVT0701CVT	See Venting Tables					
Vent Terminal - Concentric - 3" (76 mm)	KGAVT0801CVT						
Vent Terminal Bracket - 2" (51 mm)	KGAVT0101BRA						
Vent Terminal Bracket - 3" (76 mm)	KGAVT0201BRA						
Vent Kit - Rubber Coupling	KGAAC0101RVC						
Condensate Drainage Accessories							
Freeze Protect Kit - Condensate Drain Line Tape	KGAHT0101CFP	●	●	●	●	●	●
Freeze Protect Kit - Condensate Trap with Heat Pad	KGAHT0201CFP	●	●	●	●	●	●
CPVC to PVC Drain Adapters - 1/2" CPVC to 3/4" PVC	KGAAD0110PVC	●	●	●	●	●	●
Horizontal Trap Grommet - Direct Vent	KGACK0101HCK	All DV Horizontal					
Condensate Neutralizer Kit	P908 - 0001	●	●	●	●	●	●
External Trap Kit	KGAET0201ETK	●	●	●	●	●	●
Ductwork Adapter Accessories							
Furnace Base Kit for Combustible Floors	KGASB0201ALL	●	●	●	●	●	●
Coil Adapter Kits - No Offset	KGADA0101ALL	●	●	●	●	●	●
Coil Adapter Kits - Single Offset	KGADA0201ALL	●	●	●	●	●	●
Coil Adapter Kits - Double Offset	KGADA0301ALL	●	●	●	●	●	●
Return Air Base (Upflow Applications) 17.5- in. wide	KGARP0301B17	●	●	●	●	●	●
Return Air Base (Upflow Applications) 21.0- in. wide	KGARP0301B21	●	●	●	●	●	●
Return Air Base (Upflow Applications) 24.5- in. wide	KGARP0301B24	●	●	●	●	●	●
IAQ Device Duct Adapters 20.0- in. IAQ to 16 in. Side Return	KGAAD0101MEC	20"x25" IAQ Devices					
IAQ Device Duct Adapters 24.0- in. IAQ to 16 in. Side Return	KGAAD0201MEC	24"x25" IAQ Devices					
Gas Conversion Accessories							
Gas Conversion Kit - Nat to LP	AGAGC9NPS01A	●	●	●	●	●	●
Gas Conversion Kit - LP to Nat	AGAGC9PNS01A	●	●	●	●	●	●
Gas Orifice Kit - #42 (Nat Gas)	LH32DB207	●	●	●	●	●	●
Gas Orifice Kit - #43 (Nat Gas)	LH32DB202	●	●	●	●	●	●
Gas Orifice Kit - #44 (Nat Gas)	LH32DB200	●	●	●	●	●	●
Gas Orifice Kit - #45 (Nat Gas)	LH32DB205	●	●	●	●	●	●
Gas Orifice Kit - #46 (Nat Gas)	LH32DB208	●	●	●	●	●	●
Gas Orifice Kit - #47 (Nat Gas)	LH32DB078	●	●	●	●	●	●
Gas Orifice Kit - #48 (Nat Gas)	LH32DB076	●	●	●	●	●	●
Gas Orifice Kit - #54 (LP)	LH32DB203	●	●	●	●	●	●
Gas Orifice Kit - #55 (LP)	LH32DB201	●	●	●	●	●	●
Gas Orifice Kit - #56 (LP)	LH32DB206	●	●	●	●	●	●
Gas Orifice Kit - 1.25mm (LP)	LH32DB209	●	●	●	●	●	●
Gas Orifice Kit - 1.30mm (LP)	LH32DB210	●	●	●	●	●	●
Gas Valve Adapter							
Gas Valve Tower Port Adapter Kit	92- 1003	●	●	●	●	●	●
Control Accessories							
ECM Motor Simulator Kit	KGBSD0301FMS	●	●	●	●	●	●
Advanced Product Monitor - APM	KGASD0301APM	●	●	●	●	●	●
Infinity® Touch Control - Wi- Fi	SYSTXCCITW01	●	●	●	●	●	●
Infinity® Touch Control - Non- Wi- Fi	SYSTXCCITN01	●	●	●	●	●	●
IAQ Accessories							
Bottom Filter Rack - 17.5 inches (455 mm)	KGBFR0401B17	●	●	●	●	●	●
Bottom Filter Rack - 21 inches (533 mm)	KGBFR0501B21	●	●	●	●	●	●
Bottom Filter Rack - 24.5 inches (622 mm)	KGBFR0601B24	●	●	●	●	●	●
Filter Pack (6 pack) - Washable - 16x25x1 (406x635x25 mm)	KGAWF1306UFR	●	●	●	●	●	●
Filter Pack (6 pack) - Washable - 24x25x1 (610x635x25 mm)	KGAWF1506UFR	●	●	●	●	●	●
EZ-Flex Filter - 16" (406 mm)	EXPXXFIL0016	Use with EZXCAB- 1016					
EZ-Flex Filter - 20" (508 mm)	EXPXXFIL0020	Use with EZXCAB- 1020					
EZ-Flex Filter - 24" (610 mm)	EXPXXFIL0024	Use with EZXCAB- 1024					
EZ-Flex Filter with End Caps - 16" (406 mm)	EXPXXUNV0016	Use with EZXCAB- 1016					
EZ-Flex Filter with End Caps - 20" (508 mm)	EXPXXUNV0020	Use with EZXCAB- 1020					
EZ-Flex Filter with End Caps - 24" (610 mm)	EXPXXUNV0024	Use with EZXCAB- 1024					
Cartridge Media Filter - 16" (406 mm)	FILXXCAR0016	Use with FILCABXL- 1016					
Cartridge Media Filter - 20" (508 mm)	FILXXCAR0020	Use with FILCABXL- 1020					
Cartridge Media Filter - 24" (610 mm)	FILXXCAR0024	Use with FILCABXL- 1024					
Carrier Infinity® Air Purifier - 16x25 (406x635 mm)	DGAPAXX1625	Up to 1600 CFM					
Carrier Infinity® Air Purifier - 20x25 (508x635 mm)	DGAPAXX2025	Up to 2000 CFM					
Carrier Infinity® Air Purifier Repl. Filter- 16x25 (406x635 mm)	GAPACCCAR1625-A05	GAPAAXCC1625- A08					
Carrier Infinity® Air Purifier Repl. Filter- 20x25 (508x635 mm)	GAPACCCAR2025-A05	GAPAAXCC2025- A08					
Carbon Monoxide Alarm (10 pack)	COALMBNBR01- A10	●	●	●	●	●	●

● = Used with the model furnace

AIR DELIVERY - CFM

Cooling⁴ and Heating Air Delivery - CFM (Bottom Return⁵ With Filter)

(SW1-5 and SW4-3 set to OFF, except as indicated. See notes 1 and 2.)

Unit Size: 060C17-14													
Clg/CF Switch settings				External Static Pressure (ESP)									
Clg Switches	SW2-3	SW2-2	SW2-1	0.1	0.2	0.3	0.4	0.5	0.6	0.7	0.8	0.9	1.0
Clg Default:	OFF	OFF	OFF	1060	1070	1080	1080	1075	1065	1050	1035	1025	1010
CF Switches	SW3-3	SW3-2	SW3-1										
Low-Clg Default:	OFF	OFF	OFF	545	530	520	525	510	See note 4				
Cooling Airflow (SW2) Low-Cooling Airflow (SW3)	OFF	OFF	ON	545	530	520	525	510	See note 4				
	OFF	ON	OFF	710	710	710	695	690	See note 4				
	OFF	ON	ON	875	880	890	895	895	890	885	880	870	855
	ON	OFF	OFF	1060	1070	1080	1080	1075	1065	1050	1035	1025	1010
	ON	OFF	ON	1235	1240	1250	1255	1255	1250	1230	1190	1155	1115
	ON	ON	OFF	1235	1240	1250	1255	1255	1250	1230	1190	1155	1115
	ON	ON	ON	1235	1240	1250	1255	1255	1250	1230	1190	1155	1115
	Maximum Clg Airflow²				1425	1425	1405	1370	1335	1300	1260	1225	1190
CF Switches	SW3-3	SW3-2	SW3-1										
Cont. Fan Default:	OFF	OFF	OFF	545	530	520	525	510	See note 4				
Continuous Fan Airflow (SW3)	OFF	OFF	ON	545	530	520	525	510	See note 4				
	OFF	ON	OFF	710	710	710	695	690	See note 4				
	OFF	ON	ON	875	880	890	895	895	890	885	880	870	855
	ON	OFF	OFF	1060	1070	1080	1080	1075	1065	1050	1035	1025	1010
	ON	OFF	ON	1235	1240	1250	1255	1255	1250	1230	1190	1155	1115
	ON	ON	OFF	1425	1425	1405	1370	1335	1300	1260	1225	1190	1155
	ON	ON	ON	1425	1425	1405	1370	1335	1300	1260	1225	1190	1155
					1425	1425	1405	1370	1335	1300	1260	1225	1190
Heating (SW1)	Maximum Heat Airflow³			1075	1085	1095	1095	1090	1080	1065	1050	1035	1020
	Intermediate Heat Airflow³			535	515	505	515	495	See note 4				
	Minimum Heat Airflow³			420	410	415	400	380	See note 4				
Unit Size: 060C21-20													
Clg/CF Switch settings				External Static Pressure (ESP)									
Clg Switches	SW2-3	SW2-2	SW2-1	0.1	0.2	0.3	0.4	0.5	0.6	0.7	0.8	0.9	1.0
Clg Default:	OFF	OFF	OFF	1735	1735	1725	1715	1700	1685	1665	1650	1625	1605
CF Switches	SW3-3	SW3-2	SW3-1										
Low-Clg Default:	OFF	OFF	OFF	540	525	525	520	540	See note 4				
Cooling Airflow (SW2) Low-Cooling Airflow (SW3)	OFF	OFF	ON	540	525	525	520	540	See note 4				
	OFF	ON	OFF	680	725	725	720	720	See note 4				
	OFF	ON	ON	925	915	910	895	900	890	875	865	860	855
	ON	OFF	OFF	1070	1075	1080	1070	1080	1075	1055	1045	1030	1020
	ON	OFF	ON	1215	1245	1235	1220	1220	1210	1200	1195	1185	1175
	ON	ON	OFF	1380	1385	1395	1390	1395	1390	1380	1365	1355	1340
	ON	ON	ON	1735	1735	1725	1715	1700	1685	1665	1650	1625	1605
	Maximum Clg Airflow²				1955	1950	1940	1925	1905	1885	1855	1815	1745
CF Switches	SW3-3	SW3-2	SW3-1										
Cont. Fan Default:	OFF	OFF	OFF	540	525	525	520	540	See note 4				
Continuous Fan Airflow (SW3)	OFF	OFF	ON	540	525	525	520	540	See note 4				
	OFF	ON	OFF	680	725	725	720	720	See note 4				
	OFF	ON	ON	925	915	910	895	900	890	875	865	860	855
	ON	OFF	OFF	925	915	910	895	900	890	875	865	860	855
	ON	OFF	ON	925	915	910	895	900	890	875	865	860	855
	ON	ON	OFF	925	915	910	895	900	890	875	865	860	855
	ON	ON	ON	925	915	910	895	900	890	875	865	860	855
					925	915	910	895	900	890	875	865	860
Heating (SW1)	Maximum Heat Airflow³			1080	1085	1095	1090	1095	1085	1070	1055	1045	1030
	Intermediate Heat Airflow³			685	725	730	725	730	See note 4				
	Minimum Heat Airflow³			560	555	555	550	565	See note 4				

Cooling⁴ and Heating Air Delivery - CFM (Bottom Return⁵ With Filter) continued

(SW1-5 and SW4-3 set to OFF, except as indicated. See notes 1 and 2.)

Unit Size: 080C17-14			Cig/CF Switch settings			External Static Pressure (ESP)								
Cig Switches	SW2-3	SW2-2	SW2-1	0.1	0.2	0.3	0.4	0.5	0.6	0.7	0.8	0.9	1.0	
Cig Default:	OFF	OFF	OFF	1055	1065	1080	1075	1065	1050	1045	1035	1025	1005	
CF Switches	SW3-3	SW3-2	SW3-1											
Low-Cig Default:	OFF	OFF	OFF	520	505	505	495	490	See note 4					
Cooling Airflow (SW2) Low-Cooling Airflow (SW3)	OFF	OFF	ON	520	505	505	495	490	See note 4					
	OFF	ON	OFF	665	685	680	660	665	See note 4					
	OFF	ON	ON	885	895	905	900	900	895	885	875	860	845	
	ON	OFF	OFF	1055	1065	1080	1075	1065	1050	1045	1035	1025	1005	
	ON	OFF	ON	1245	1245	1255	1255	1260	1255	1250	1235	1220	1185	
	ON	ON	OFF	1245	1245	1255	1255	1260	1255	1250	1235	1220	1185	
	ON	ON	ON	1245	1245	1255	1255	1260	1255	1250	1235	1220	1185	
	Maximum Cig Airflow²				1520	1485	1450	1415	1375	1335	1300	1265	1225	1190
CF Switches	SW3-3	SW3-2	SW3-1											
Cont. Fan Default:	OFF	OFF	OFF	520	505	505	495	490	See note 4					
Continuous Fan Airflow (SW3)	OFF	OFF	ON	520	505	505	495	490	See note 4					
	OFF	ON	OFF	665	685	680	660	665	See note 4					
	OFF	ON	ON	885	895	905	900	900	895	885	875	860	845	
	ON	OFF	OFF	1055	1065	1080	1075	1065	1050	1045	1035	1025	1005	
	ON	OFF	ON	1245	1245	1255	1255	1260	1255	1250	1235	1220	1185	
	ON	ON	OFF	1425	1425	1405	1405	1375	1335	1300	1265	1225	1190	
	ON	ON	ON	1425	1425	1405	1405	1375	1335	1300	1265	1225	1190	
	Heating (SW1)	Maximum Heat Airflow³			1520	1485	1450	1415	1375	1335	1300	1265	1225	1190
Intermediate Heat Airflow³			755	745	755	755	765	See note 4						
Minimum Heat Airflow³			620	625	630	620	610	See note 4						
Unit Size: 080C21-20			Cig/CF Switch settings			External Static Pressure (ESP)								
Cig Switches	SW2-3	SW2-2	SW2-1	0.1	0.2	0.3	0.4	0.5	0.6	0.7	0.8	0.9	1.0	
Cig Default:	OFF	OFF	OFF	1745	1755	1755	1760	1755	1750	1745	1725	1705	1685	
CF Switches	SW3-3	SW3-2	SW3-1											
Low-Cig Default:	OFF	OFF	OFF	700	710	750	725	750	See note 4					
Cooling Airflow (SW2) Low-Cooling Airflow (SW3)	OFF	OFF	ON	700	710	750	725	750	See note 4					
	OFF	ON	OFF	830	860	870	890	960	See note 4					
	OFF	ON	ON	1045	1045	1060	1070	1070	1070	1095	1090	1080	1070	
	ON	OFF	OFF	1215	1220	1245	1240	1235	1235	1225	1220	1235	1235	
	ON	OFF	ON	1370	1370	1390	1390	1400	1395	1400	1390	1390	1385	
	ON	ON	OFF	1745	1755	1755	1760	1755	1750	1745	1725	1705	1685	
	ON	ON	ON	1745	1755	1755	1760	1755	1750	1745	1725	1705	1685	
	Maximum Cig Airflow²				1920	1920	1945	1945	1945	1960	1950	1940	1915	1900
CF Switches	SW3-3	SW3-2	SW3-1											
Cont. Fan Default:	OFF	OFF	OFF	700	710	750	725	750	See note 4					
Continuous Fan Airflow (SW3)	OFF	OFF	ON	700	710	750	725	750	See note 4					
	OFF	ON	OFF	830	860	870	890	960	See note 4					
	OFF	ON	ON	1045	1045	1060	1070	1070	1070	1095	1090	1080	1070	
	ON	OFF	OFF	1215	1220	1245	1240	1235	1235	1225	1220	1235	1235	
	ON	OFF	ON	1370	1370	1390	1390	1400	1395	1400	1390	1390	1385	
	ON	ON	OFF	1370	1370	1390	1390	1400	1395	1400	1390	1390	1385	
	ON	ON	ON	1370	1370	1390	1390	1400	1395	1400	1390	1390	1385	
	Heating (SW1)	Maximum Heat Airflow³			1340	1355	1370	1385	1380	1385	1400	1400	1385	1380
Intermediate Heat Airflow³			780	810	835	840	845	See note 4						
Minimum Heat Airflow³			595	595	600	595	605	See note 4						

Cooling⁴ and Heating Air Delivery - CFM (Bottom Return⁵ With Filter) continued

(SW1-5 and SW4-3 set to OFF, except as indicated. See notes 1 and 2.)

Unit Size: 100C21-22			Cig/CF Switch settings			External Static Pressure (ESP)								
Cig Switches	SW2-3	SW2-2	SW2-1	0.1	0.2	0.3	0.4	0.5	0.6	0.7	0.8	0.9	1.0	
Cig Default:	OFF	OFF	OFF	1820	1825	1840	1845	1840	1835	1825	1805	1780	1770	
CF Switches	SW3-3	SW3-2	SW3-1											
Low-Cig Default:	OFF	OFF	OFF	750	740	745	730	715	See note 4					
Cooling Airflow (SW2) Low-Cooling Airflow (SW3)	OFF	OFF	ON	750	740	745	730	715	See note 4					
	OFF	ON	OFF	900	900	915	910	905	See note 4					
	OFF	ON	ON	1070	1075	1095	1095	1090	1085	1095	1080	1065	1070	
	ON	OFF	OFF	1280	1285	1305	1305	1310	1305	1295	1300	1290	1285	
	ON	OFF	ON	1440	1445	1465	1465	1470	1485	1480	1485	1475	1460	
	ON	ON	OFF	1820	1825	1840	1845	1840	1835	1825	1805	1780	1770	
	ON	ON	ON	2135	2140	2140	2135	2140	2130	2115	2100	2070	2015	
Maximum Cig Airflow²				2160	2165	2175	2170	2160	2150	2135	2120	2065	2020	
CF Switches	SW3-3	SW3-2	SW3-1											
Cont. Fan Default:	OFF	OFF	OFF	750	740	745	730	715	See note 4					
Continuous Fan Airflow (SW3)	OFF	OFF	ON	750	740	745	730	715	See note 4					
	OFF	ON	OFF	900	900	915	910	905	See note 4					
	OFF	ON	ON	1070	1075	1095	1095	1090	1085	1095	1080	1065	1070	
	ON	OFF	OFF	1280	1285	1305	1305	1310	1305	1295	1300	1290	1285	
	ON	OFF	ON	1440	1445	1465	1465	1470	1485	1480	1485	1475	1460	
	ON	ON	OFF	1440	1445	1465	1465	1470	1485	1480	1485	1475	1460	
	ON	ON	ON	1440	1445	1465	1465	1470	1485	1480	1485	1475	1460	
Heating (SW1)	Maximum Heat Airflow³			1570	1575	1595	1595	1600	1605	1600	1600	1590	1575	
	Intermediate Heat Airflow³			950	955	965	975	970	See note 4					
	Minimum Heat Airflow³			755	745	750	735	720	See note 4					
Unit Size: 120C24-22			Cig/CF Switch settings			External Static Pressure (ESP)								
Cig Switches	SW2-3	SW2-2	SW2-1	0.1	0.2	0.3	0.4	0.5	0.6	0.7	0.8	0.9	1.0	
Cig Default:	OFF	OFF	OFF	1850	1855	1860	1855	1850	1830	1805	1775	1750	1730	
CF Switches	SW3-3	SW3-2	SW3-1											
Low-Cig Default:	OFF	OFF	OFF	930	925	915	900	885	See note 4					
Cooling Airflow (SW2) Low-Cooling Airflow (SW3)	OFF	OFF	ON	765	745	740	705	680	See note 4					
	OFF	ON	OFF	930	925	915	900	885	See note 4					
	OFF	ON	ON	1095	1100	1110	1105	1085	See note 4					
	ON	OFF	OFF	1265	1255	1265	1280	1275	1285	1270	1260	1250	1230	
	ON	OFF	ON	1465	1455	1470	1465	1465	1470	1455	1450	1435	1415	
	ON	ON	OFF	1850	1855	1860	1855	1850	1830	1805	1775	1750	1730	
	ON	ON	ON	2200	2200	2200	2190	2185	2170	2145	2085	1990	1890	
Maximum Cig Airflow²				2200	2200	2200	2190	2185	2170	2145	2085	1990	1890	
CF Switches	SW3-3	SW3-2	SW3-1											
Cont. Fan Default:	OFF	OFF	OFF	930	925	915	900	885	See note 4					
Continuous Fan Airflow (SW3)	OFF	OFF	ON	765	745	740	705	680	See note 4					
	OFF	ON	OFF	930	925	915	900	885	See note 4					
	OFF	ON	ON	1095	1100	1110	1105	1085	See note 4					
	ON	OFF	OFF	1265	1255	1265	1280	1275	1285	1270	1260	1250	1230	
	ON	OFF	ON	1465	1455	1470	1465	1465	1470	1455	1450	1435	1415	
	ON	ON	OFF	1465	1455	1470	1465	1465	1470	1455	1450	1435	1415	
	ON	ON	ON	1465	1455	1470	1465	1465	1470	1455	1450	1435	1415	
Heating (SW1)	Maximum Heat Airflow³			1815	1820	1825	1820	1815	1795	1775	1745	1720	1700	
	Intermediate Heat Airflow³			1095	1100	1110	1105	1085	See note 4					
	Minimum Heat Airflow³			905	900	890	875	855	See note 4					

- Nominal 350 CFM/ton cooling airflow is delivered with SW1-5 and SW4-3 set to OFF.
Set SW1-5 to ON for nominal 400 CFM/ton (+15% airflow).
Set SW4-3 to ON for nominal 325 CFM/ton (-7% airflow).
Set both SW1-5 and SW4-3 to ON for nominal 370 CFM/ton (+7% airflow).
This applies to Cooling and Low-Cooling airflow, but does not affect continuous fan airflow.

The above adjustments in airflow are subject to motor horsepower range/capacity.

- Maximum cooling airflow is achieved when switches SW2-1, SW2-2, SW2-3 and SW1-5 are set to ON, and SW4-3 is set to OFF.
- All heating CFM's are when low/medium heat rise adjustment switch (SW1-3) and comfort/efficiency adjustment switch (SW1-4) are both set to OFF.
- Ductwork must be sized for high-heating CFM within the operational range of ESP. Operation within the blank areas of the chart is not recommended because high-heat operation will be above 1.0 ESP.
- All airflow on 21" casing size furnaces are 5% less on side return only installations.
- Return air above 1800 CFM on 24.5" casing sizes requires two sides, one side and bottom or bottom only, to allow sufficient airflow to the furnace.

MAXIMUM ALLOWABLE EXPOSED VENT LENGTHS INSULATION TABLE

Table 1 – Maximum Allowable Exposed Vent Length in Unconditioned Space

Winter Design Temp °F	Unit Size	40,000* BTUH									60,000 BTUH										
		Uninsulated			3/8-in. Insulation			1/2-in. Insulation			Uninsulated			3/8-in. Insulation			1/2-in. Insulation				
		1 ½	2	2 ½	1 ½	2	2 ½	1 ½	2	2 ½	1 ½	2	2 ½	3	1 ½	2	2 ½	3	1 ½	2	2 ½
20	20	20	20	20	50	45	20	60	50	20	30	30	25	20	75	65	60	20	85	75	65
0	10	5	5	20	25	10	20	30	25	15	15	10	10	20	40	30	25	20	45	40	30
-20	5			20	15	10	20	20	15	10	5			20	25	20	15	20	30	25	20
-40				15	10	5	15	15	10	5				20	15	15	10	20	20	15	10

Winter Design Temp °F	Unit Size	80,000 BTUH													
		Uninsulated			3/8-in. Insulation			1/2-in. Insulation							
		1 ½	2	2 ½	3	4	1 ½	2	2 ½	3	4	1 ½	2	2 ½	3
20	15	40	40	35	30	15	50	90	75	65	15	50	70	70	70
0	15	20	15	10	5	15	50	45	35	30	15	50	50	40	35
-20	15	10	5			15	35	30	20	15	15	40	30	25	15
-40	10	5				15	25	20	15	5	15	30	25	20	10

Winter Design Temp °F	Unit Size	100,000 BTUH										
		Uninsulated			3/8-in. Insulation			1/2-in. Insulation				
		2	2 ½	3	4	2	2 ½	3	4	2	2 ½	3
20	20	50	40	35	20	80	95	80	20	80	105	90
0	20	20	15	10	20	55	45	35	20	65	55	45
-20	15	10	5		20	35	30	20	20	45	35	25
-40	10	5			20	25	20	10	20	30	25	15

Winter Design Temp °F	Unit Size	120,000 BTUH						140,000 BTUH											
		Uninsulated			3/8-in. Insulation			1/2-in. Insulation			Uninsulated			3/8-in. Insulation			1/2-in. Insulation		
		2 ½	3	4	2 ½	3	4	2 ½	3	4	2 ½	3	4	2 ½	3	4	2 ½	3	4
20	10	50	40	10	75	95	10	75	105	5	55	50	5	65	105	5	65	125	
0	10	20	15	10	55	45	10	65	50	5	25	15	5	65	50	5	65	60	
-20	10	10		10	35	25	10	45	30	5	10	5	5	45	30	5	50	40	
-40	10	5		10	25	15	10	30	20	5	5		5	30	20	5	35	25	

Maximum Allowable Exposed Vent Length in Unconditioned Space (Metric)

Winter Design Temp °C	Unit Size	40,000* BTUH									60,000 BTUH										
		Uninsulated			3/8-in. Insulation			1/2-in. Insulation			Uninsulated			3/8-in. Insulation			1/2-in. Insulation				
		38	51	64	38	51	64	38	51	64	38	51	64	76	38	51	64	76	38	51	64
-7	6.1	6.1	6.1	6.1	15.2	13.7	6.1	18.3	15.2	6.1	9.1	9.1	7.6	6.1	22.9	19.8	18.3	6.1	25.9	22.9	19.8
-18	3.0	1.5	1.5	6.1	7.6	6.1	6.1	9.1	7.6	4.6	4.6	3.0	3.0	6.1	12.2	9.1	7.6	6.1	13.7	12.2	9.1
-29	1.5			6.1	4.6	3.0	6.1	6.1	4.6	3.0	1.5			6.1	7.6	6.1	4.6	6.1	9.1	7.6	6.1
-40				4.6	3.0	1.5	4.6	4.6	3.0	1.5				6.1	4.6	4.6	3.0	6.1	6.1	4.6	3.0

Winter Design Temp °C	Unit Size	80,000 BTUH													
		Uninsulated			3/8-in. Insulation			1/2-in. Insulation							
		38	51	64	76	102	38	51	64	76	102	38	51	64	76
-7	4.6	12.2	12.2	10.7	9.1	4.6	15.2	27.4	22.9	19.8	4.6	15.2	21.3	21.3	21.3
-18	4.6	6.1	4.6	3.0	1.5	4.6	15.2	13.7	10.7	9.1	4.6	15.2	15.2	12.2	10.7
-29	4.6	3.0	1.5			4.6	10.7	9.1	6.1	4.6	4.6	12.2	9.1	7.6	4.6
-40	3.0	1.5				4.6	7.6	6.1	4.6	1.5	4.6	9.1	7.6	6.1	3.0

Winter Design Temp °C	Unit Size	100,000 BTUH										
		Uninsulated			3/8-in. Insulation			1/2-in. Insulation				
		51	64	76	102	51	64	76	102	51	64	76
-7	6.1	15.2	12.2	10.7	6.1	24.4	28.9	24.4	6.1	24.4	32.0	27.4
-18	6.1	6.1	4.6	3.0	6.1	16.8	13.7	10.7	6.1	19.8	16.7	13.7
-29	4.6	3.0	1.5		6.1	10.7	9.1	6.1	6.1	13.7	10.7	7.6
-40	3.0	1.5			6.1	7.6	6.1	3.0	6.1	9.1	7.6	4.6

Winter Design Temp °C	Unit Size	120,000 BTUH						140,000 BTUH											
		Uninsulated			3/8-in. Insulation			1/2-in. Insulation			Uninsulated			3/8-in. Insulation			1/2-in. Insulation		
		64	76	102	64	76	102	64	76	102	64	76	102	64	76	102	64	76	102
-7	3.0	15.2	12.2	3.0	22.9	28.9	3.0	22.9	32.0	1.5	16.7	15.2	1.5	19.8	32.0	1.5	19.8	38.1	
-18	3.0	6.1	4.6	3.0	16.8	13.7	3.0	19.8	15.2	1.5	7.6	4.6	1.5	19.8	15.2	1.5	19.8	18.3	
-29	3.0	3.0		3.0	10.7	7.6	3.0	13.7	9.1	1.5	3.0	1.5	1.5	13.7	9.1	1.5	15.2	12.2	
-40	3.0	1.5		3.0	7.6	4.6	3.0	9.1	6.1	1.5	1.5		1.5	9.1	6.1	1.5	35	7.6	

* Pipe length (ft) specified for maximum pipe lengths located in unconditioned spaces. Pipes located in unconditioned space cannot exceed total allowable pipe length calculated from Table 2.

† Insulation thickness based on R value of 3.5 per in.

MAXIMUM EQUIVALENT VENT LENGTH

NOTE: Maximum Equivalent Vent Length (MEVL) includes standard and concentric vent termination and does NOT include elbows. Use Table 3 - Deductions from Maximum Equivalent Vent Length to determine allowable vent length for each application.

Table 2 – Maximum Equivalent Vent Length - Ft.

Ft.																	
Unit Size		60,000				80,000				100,000				120,000			
Altitude (feet)	Pipe Dia. (in)	1 ½	2	2 ½	3	1 ½	2	2 ½	3	4	2	2 ½	3	4	2 ½	3	4
	0- 2000	50	100	175	200	30	95	130	175	200	45	80	175	200	10	75	185
	2001- 3000	45	95	165	185	70	125	165	185	40	75	165	185	5	65	165	
	3001- 4000	40	90	155	175												25
	4001- 4500	35	85	150	170	23	70	110	150	165	36	70	155	170	N/A	60	160
	4501- 5000		80		165	150			165	140			155				
	5001- 6000	37	75	140	155	22	100	135	150	33	70	140	155	N/A	50	140	
	6001- 7000	35	70	130	145	20	90	125	140	31		135	145				
	7001- 8000	32	66	120	135	18	66	90	120	125	29	66	125	135	N/A	46	130
	8001- 9000	30	62	115	125	17	62	80	110	115	27	62	115	125			
9001- 10000	27	57	105	115	15	57	75	100	105	24	57	100	115	N/A	39	115	

Meters																	
Unit Size		60,000				80,000				100,000				120,000			
Altitude (meters)	Pipe Dia. (mm)	38	51	64	76	38	51	64	76	102	51	64	76	102	64	76	102
	0- 610	15.2	30.4	53.3	60.9	9.1	28.9	39.6	53.3	60.9	13.7	24.3	53.3	60.9	3.0	22.8	56.3
	611- 914	13.7	28.9	50.2	56.3	21.3	38.1	50.2	56.3	12.1	22.8	50.2	56.3	1.5	19.8	50.2	
	915- 1219	12.1	27.4	47.2	53.3												7.6
	1220- 1370	10.6	25.9	45.7	51.8	7.0	33.5	45.7	50.2	10.9	21.3	47.2	51.8	N/A	18.2	48.7	
	1371- 1524		24.3		50.2	44.1		48.7	45.7			50.2					
	1525- 1829	11.2	22.8	42.6	47.2	6.7	30.4	41.1	45.7	10.0	21.3	42.6	47.2	N/A	15.2	42.6	
	1830- 2134	10.6	21.3	39.6	44.1	6.0	27.4	38.1	42.6	9.4		41.1	44.1				
	2135- 2438	9.7	20.1	36.5	41.1	5.4	20.1	27.4	36.5	38.1	8.8	20.1	38.1	41.1	N/A	14.0	39.6
	2439- 2743	9.1	18.8	35.0	38.1	5.1	18.8	24.3	33.5	35.0	8.2	18.8	35.0	38.1			
2744- 3048	8.2	17.3	32.0	35.0	4.5	17.3	22.8	30.4	32.0	7.3	17.3	30.4	35.0	N/A	11.8	35.0	

ELBOW CONFIGURATIONS

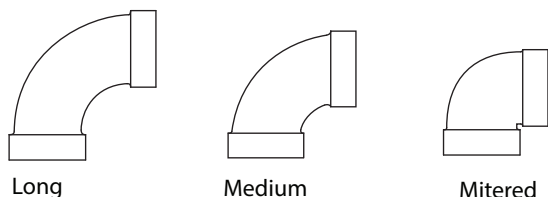

VENT TERMINAL CONFIGURATIONS

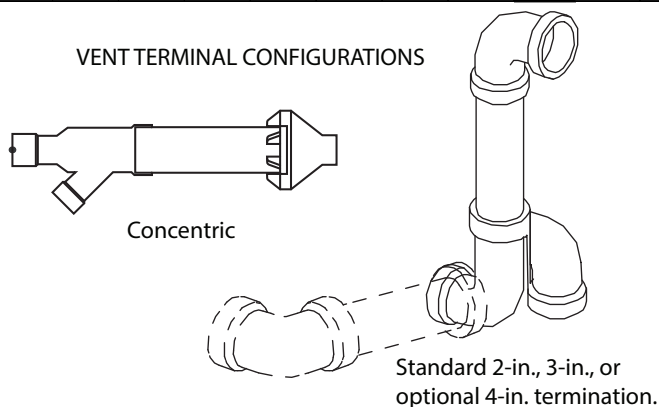

Table 3 – Deductions from Maximum Equivalent Vent Length - Ft. (M)

Pipe Diameter (in):	1-1/2		2		2-1/2		3		4	
Mitered 90° Elbow	8	(2.4)	8	(2.4)	8	(2.4)	8	(2.4)	8	(2.4)
Medium Radius 90° Elbow	5	(1.5)	5	(1.5)	5	(1.5)	5	(1.5)	5	(1.5)
Long Radius 90° Elbow	3	(0.9)	3	(0.9)	3	(0.9)	3	(0.9)	3	(0.9)
Mitered 45° Elbow	4	(1.2)	4	(1.2)	4	(1.2)	4	(1.2)	4	(1.2)
Medium Radius 45° Elbow	2.5	(0.8)	2.5	(0.8)	2.5	(0.8)	2.5	(0.8)	2.5	(0.8)
Long Radius 45° Elbow	1.5	(0.5)	1.5	(0.5)	1.5	(0.5)	1.5	(0.5)	1.5	(0.5)
Tee	16	(4.9)	16	(4.9)	16	(4.9)	16	(4.9)	16	(4.9)
Concentric Vent Termination	NA		0	(0.0)	NA		0	(0.0)	NA	
Standard Vent Termination	0	(0.0)	0	(0.0)	0	(0.0)	0	(0.0)	0	(0.0)

NOTES:

1. Use only the smallest diameter pipe possible for venting. Over-sizing may cause flame disturbance or excessive vent terminal icing or freeze-up.
2. NA - Not allowed. Pressure switch will not close, or flame disturbance may result.
3. Vent sizing for Canadian installations over 4500 ft. (1370 M) above sea level are subject to acceptance by the local authorities having jurisdiction.
4. Size both the combustion air and vent pipe independently, then use the larger size for both pipes.
5. Assume the two 45° elbows equal one 90° elbow. Wide radius elbows are desirable and may be required in some cases.
6. Elbow and pipe sections within the furnace casing and at the vent termination should not be included in vent length or elbow count.
7. The minimum pipe length is 5 ft. (2 M) linear feet (meters) for all applications.
8. Use 3- in. (76 mm) diameter vent termination kit for installations requiring 4- in. (102 mm) diameter pipe.

Venting System Length Calculations

The Total Equivalent Vent Length (TEVL) for **EACH** combustion air or vent pipe equals the length of the venting system, plus the equivalent length of elbows used in the venting system from Table 3.

Standard vent terminations or factory accessory concentric vent terminations count for zero deduction.

See vent system manufacturer's data for equivalent lengths of flexible vent pipe or other termination systems. **DO NOT ASSUME** that one foot of flexible vent pipe equals one foot of straight PVC/ABS DWV vent pipe.

Compare the Total Equivalent Vent Length to the Maximum Equivalent Vent Lengths in Table 2.

Example 1

A direct-vent 60,000 BTUH furnace installed at 2100 ft. (640M). Venting system includes **FOR EACH PIPE:**

70 feet (22 M) of vent pipe, 65 feet (20 M) of combustion air inlet pipe, (3) 90° long-radius elbows, (2) 45° long-radius elbows, and a factory accessory concentric vent kit.

Can this application use 2" (50 mm ND) PVC/ABS DWV vent piping?

Measure the required linear length of air inlet and vent pipe; insert the longest of the two here					70 ft. (22 M)	Use length of the longer of the vent or air inlet piping system
Add equiv length of (3) 90° long-radius elbows (use the highest number of elbows for either the vent or inlet pipe)	3	x	3 ft. (0.9 M)	=	9 ft. (2.7 M)	From Table 3
Add equiv length of (2) 45° long-radius elbows (use the highest number of elbows for either the vent or inlet pipe)	2	x	1.5 ft. (0.5 M)	=	3 ft. (0.9 M)	From Table 3
Add equiv length of factory concentric vent term					0 ft.	From Table 3
Add correction for flexible vent pipe, if any					0 ft.	From Vent Manufacturer's instructions; zero for PVC/ABS DWV
Total Equivalent Vent Length (TEVL)					82 ft. (25 M)	Add all of the above lines
Maximum Equivalent Vent Length (MEVL)					95 ft. (29 M)	For 2" pipe from Table 2
Is TEVL less than MEVL?					YES	Therefore, 2" pipe MAY be used

Example 2

A direct-vent 60,000 BTUH furnace installed at 2100 ft. (640M). Venting system includes **FOR EACH PIPE:**

100 feet (30 M) of vent pipe, 95 feet (29 M) of combustion air inlet pipe, (3) 90° long-radius elbows, and a polypropylene concentric vent kit. Also includes 20 feet (6.1 M) of flexible polypropylene vent pipe, included within the 100 feet (30 M) of vent pipe.

VERIFY FROM POLYPROPYLENE VENT MANUFACTURER'S INSTRUCTIONS for the multiplier correction for flexible vent pipe.

Can this application use 60mm o.d. (2") polypropylene vent piping? If not, what size piping can be used?

Measure the required linear length of RIGID air inlet and vent pipe; insert the longest of the two here: 100 ft. Of rigid pipe - 20 ft. Of flexible pipe				=	80 ft. (24 M)	Use length of the longer of the vent or air inlet piping system
Add equiv length of (3) 90° long-radius elbows (use the highest number of elbows for either the vent or inlet pipe)	3	x	5 ft. (1.5 M)	=	15 ft. (4.6 M)	Example from polypropylene vent manufacturer's instructions. Verify from vent manufacturer's instructions.
Add equiv length of 45° long-radius elbows (use the highest number of elbows for either the vent or inlet pipe)	0	x		=	0 ft. (0 M)	
Add equiv length of factory concentric vent term	9	x	3.3 ft. (0.9 M)	=	30 ft. (9 M)	
Add correction for flexible vent pipe, if any	2*	x	20 ft. (6.1 M)	=	40 ft. (12.2 M)	
* VERIFY FROM VENT MANUFACTURER'S INSTRUCTIONS; For example only, assume 1 meter of flexible 60mm (2") or 80mm (3") polypropylene pipe equals 2.0 meters (6.5 ft.) of PVC/ABS pipe.						
Total Equivalent Vent Length (TEVL)					165 ft. (50 M)	Add all of the above lines
Maximum Equivalent Vent Length (MEVL)					95 ft. (29 M)	For 2" pipe from Table 2
Is TEVL less than MEVL?					NO	Therefore, 60mm (2") pipe may NOT be used; try 80mm (3")
Maximum Equivalent Vent Length (MEVL)					185 ft. (57 M)	For 3" pipe from Table 2
Is TEVL less than MEVL?					YES	Therefore, 80mm (3") pipe MAY be used

RETURN AIR TEMPERATURE

This furnace is designed for continuous return-air minimum temperature of 60°F (15°C) db or intermittent operation down to 55°F (13°C) db such as when used with a night setback thermometer. Return-air temperature must not exceed 80°F (27°C) db. Failure to follow these return air limits may affect reliability of heat exchangers, motors and controls.

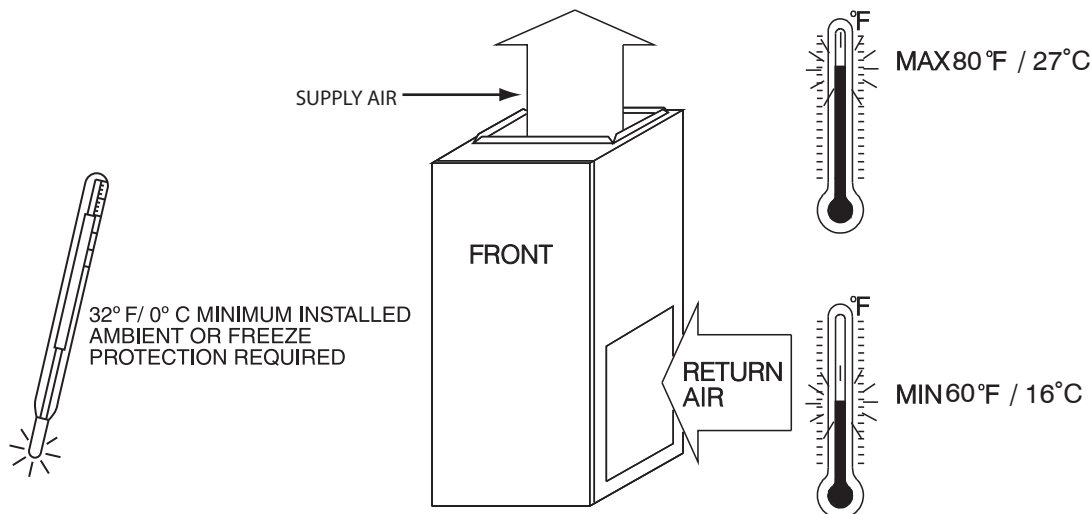

A10490

MINIMUM CLEARANCES TO COMBUSTIBLE MATERIALS

POSITION	CLEARANCE
Rear	0 (0 mm)
Front (Combustion air openings in furnace and in structure)	1 in. (25 mm)
Required for service**	24 in. (610 mm)*
All Sides of Supply Plenum**	1 in. (25 mm)
Sides	0 (0 mm)
Vent	0 (0 mm)
Top of Furnace	1 in. (25 mm)

* Recommended

**Consult your local building codes

VENTILATED COMBUSTION-AIR PIPE FOR ATTIC/CRAWLSPACE APPLICATIONS

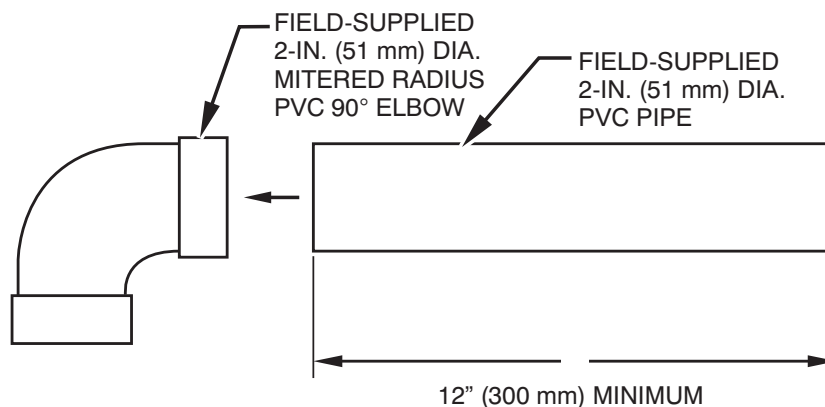

NOTE: See Installation Instructions for specific venting configurations.

A12376

DOWNFLOW SUBBASE

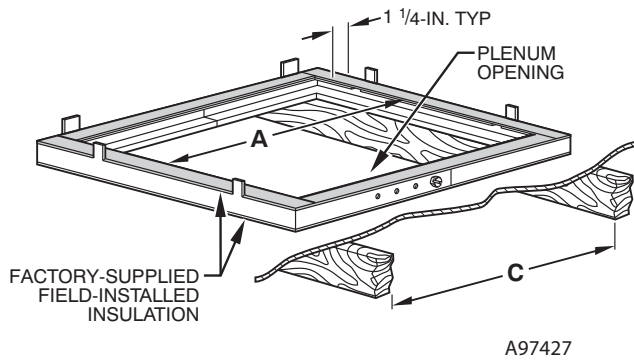

Assembled

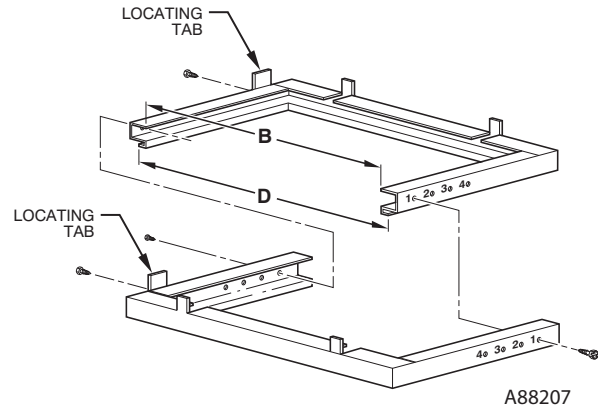

Disassembled

DIMENSIONS (IN. / MM)						
FURNACE CASING WIDTH	FURNACE IN DOWNFLOW APPLICATION	PLENUM OPENING*		FLOOR OPENING		HOLE NO. FOR WIDTH ADJUSTMENT
		A	B	C	D	
17- 1/2 (444.5)	Furnace with or without Cased Coil Assembly or Coil Box	15- 1/8 (384.2)	19 (482.6)	16- 3/4 (425.5)	20- 3/8 (517.5)	3
21 (533.4)	Furnace with or without Cased Coil Assembly or Coil Box	18- 5/8 (396.4)	19 (482.6)	20- 1/4 (514.4)	20- 3/8 (517.5)	2
24- 1/2 (622.3)	Furnace with or without Cased Coil Assembly or Coil Box	22- 1/8 (562.0)	19 (482.6)	23- 3/4 (603.3)	20- 3/8 (517.5)	1

*The plenum should be constructed 1/4- in. (6 mm) smaller in width and depth than the plenum dimensions shown above.

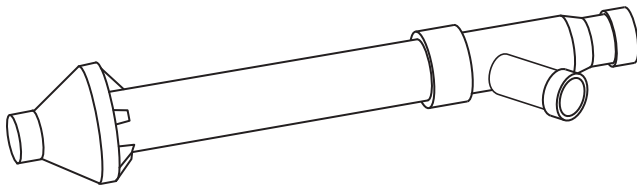

Concentric Vent Kit

A93086

A concentric vent kit allows vent and combustion-air pipes to terminate through a single exit in a roof or side wall. One pipe runs inside the other allowing venting through the inner pipe and combustion air to be drawn in through the outer pipe.

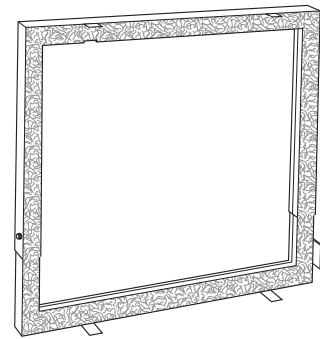

Downflow Subbase

A88202

One base fits all furnace sizes. The base is designed to be installed between the furnace and a combustible floor when no coil box is used or when a coil box other than a Carrier cased coil is used. It is CSA design certified for use with Carrier branded furnaces when installed in downflow applications.

MEDIA FILTER CABINET

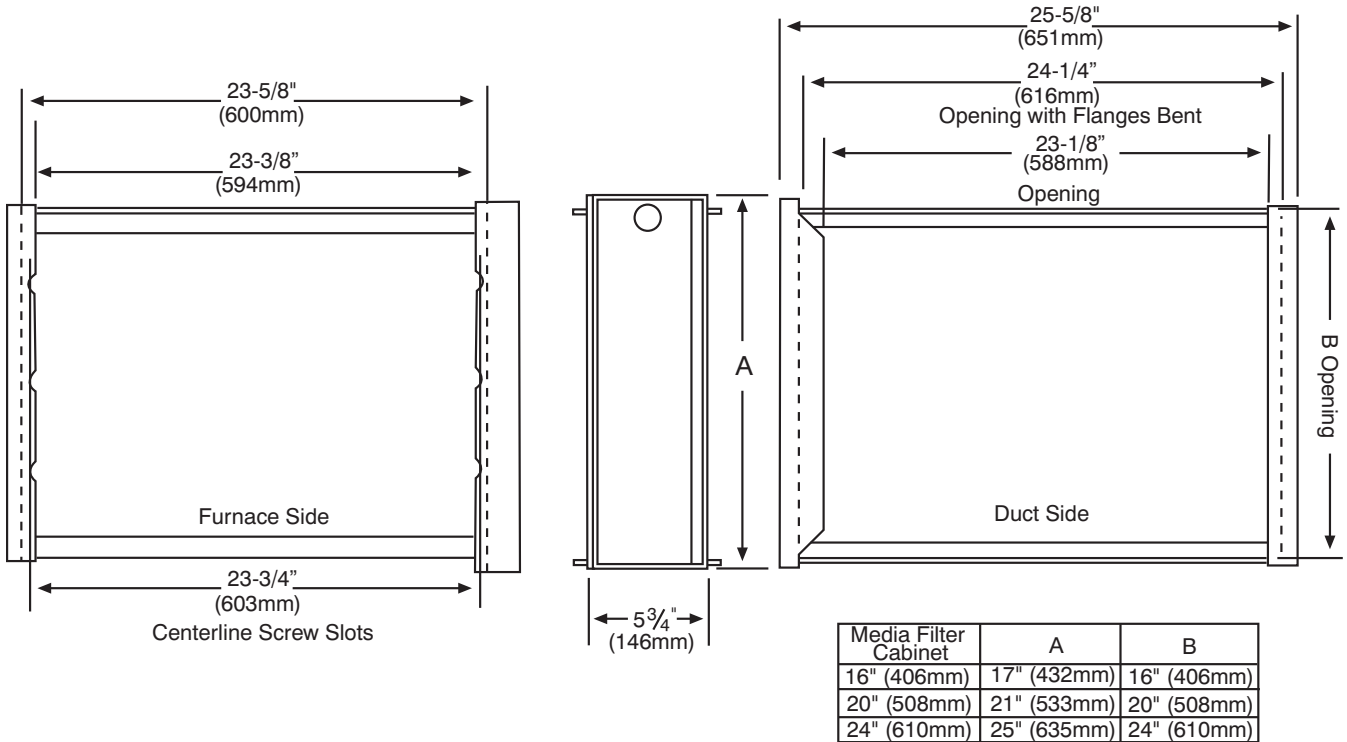

NOTE: Media cabinet is matched to the bottom opening on furnace. May also be used for side return.

A12428

TYPICAL WIRING SCHEMATIC

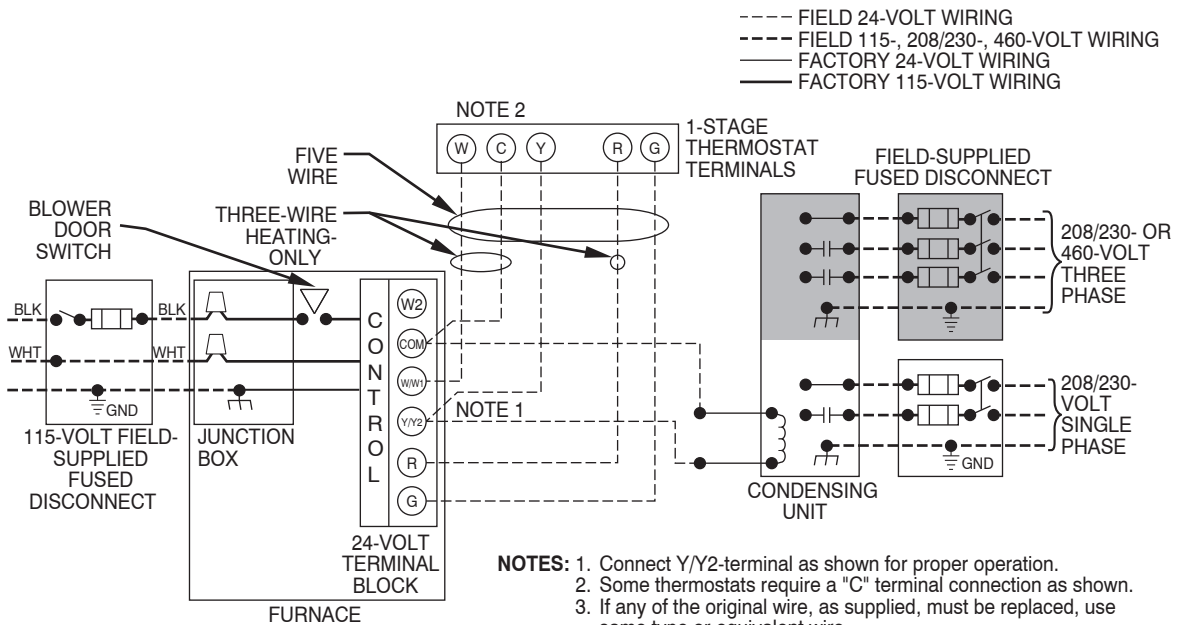

A11401

GUIDE SPECIFICATIONS

General

System Description

Furnish a _____ 4-way multipoise modulating gas-fired condensing furnace for use with natural gas or propane (factory-authorized conversion kit required for propane); furnish external media cabinet for use with accessory media filter or standard filter.

Quality Assurance

Unit will be designed, tested and constructed to the current ANSI Z 21.47/CSA 2.3 design standard for gas-fired central furnaces.

Unit will be third party certified by CSA to the current ANSI Z 21.47/CSA 2.3 design standard for gas-fired central furnaces. Unit will carry the CSA Blue Star® and Blue Flame® labels. Unit efficiency testing will be performed per the current DOE test procedure as listed in the Federal Register.

Unit will be certified for capacity and efficiency and listed in the latest AHRI Consumer's Directory of Certified Efficiency Ratings.

Unit will carry the current Federal Trade Commission Energy Guide efficiency label.

Delivery, Storage, and Handling

Unit will be shipped as single package only and is stored and handled per unit manufacturer's recommendations.

Warranty (for inclusion by specifying engineer)

U.S. and Canada only. Warranty certificate available upon request.

Equipment

Blower Wheel and ECM Blower Motor

Galvanized blower wheel shall be centrifugal type, statically and dynamically balanced. Blower motor of ECM type shall be permanently lubricated with sealed ball bearings, of _____ hp, and have infinitely variable speed from 300-1300 RPM operating only when motor inputs are provided. Blower motor shall be direct drive and soft mounted to the blower housing to reduce vibration transmission.

Filters

Furnace shall have reusable-type filters. Filter shall be _____ in. (mm) X _____ in. (mm). An accessory highly efficient Media Filter is available as an option. _____ Media Filter.

Casing

Casing shall be of .030 in. thickness minimum, pre-painted steel.

Draft Inducer Motor

Draft inducer motor shall be variable-speed design.

Primary Heat Exchangers

Primary heat exchangers shall be 3-Pass corrosion-resistant aluminumized steel of fold-and-crimp sectional design and applied operating under negative pressure.

Secondary Heat Exchangers

Secondary heat exchangers shall be of a stainless steel flow-through of fin-and-tube design and applied operating under negative pressure.

Controls

Controls shall include a micro-processor-based integrated electronic control board with at least 16 service troubleshooting codes displayed via diagnostic flashing LED light on the control, a self-test feature that checks all major functions of the furnace, and a replaceable automotive-type circuit protection fuse. Multiple operational settings available, including separate blower speeds for all modulating heating capacities, low cooling, high cooling and continuous fan. Continuous fan speed may be adjusted from the thermostat. Cooling airflow will be selectable between 325 to 400 CFM per ton of air conditioning. Features will also include temporary reduced airflow in the cooling mode for improved dehumidification when an Infinity® Control or TP-PRH edge®L is selected as the thermostat.

Operating Characteristics

Heating capacity shall be _____ Btuh input; _____ Btuh output capacity.

Fuel Gas Efficiency shall be _____ AFUE.

Air delivery shall be _____ cfm minimum at 0.50 in. W.C. external static pressure.

Dimensions shall be: depth _____ in. (mm); width _____ in. (mm); height _____ in. (mm) (casing only).

Height shall be _____ in. (mm) with A/C coil and _____ in. (mm) overall with plenum.

Electrical Requirements

Electrical supply shall be 115 volts, 60 Hz, single-phase (nominal). Minimum wire size shall be _____ AWG; maximum fuse size of HACR-type designated circuit breaker shall be _____ amps.

Special Features

Refer to section of the product data identifying accessories and descriptions for specific features and available enhancements.