

Flow sensor

Calibrated ultrasonic flow sensor, temperature and glycol compensated. With DC 0.5...10 V output signal. This sensor can be used in closed cold and warm water systems and is robust against dirt and magnetite. There is also a low pressure drop across the sensor.

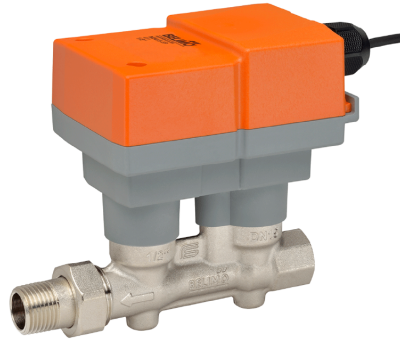

5-year warranty

Type Overview

Type	DN	DN ["]	FS [l/s]	FS [GPM]	Δp [kPa]	Δp [psi]	Cv	Output signal active volumetric flow
FM050	15	1/2	0.42	6.6	12	1.75	5	0.5...10 V
FM075	20	3/4	0.78	12.4	13	1.89	9	0.5...10 V
FM100	25	1	1.38	21.8	8.1	1.18	20	0.5...10 V
FM125	32	1 1/4	2.16	34.2	6.2	0.9	36	0.5...10 V
FM150	40	1 1/2	3.00	47.5	7.0	1.02	47	0.5...10 V
FM200	50	2	5.76	91.2	15	2.16	62	0.5...10 V

FS: Full scale, maximum flow

 Δp : Pressure drop at FS

Technical data

Electrical Data	Nominal voltage	AC/DC 24 V
	Nominal voltage frequency	50/60 Hz
	Nominal voltage range	AC 19.2...28.8 V / DC 21.6...28.8 V
	Power consumption AC	1 VA
	Power consumption DC	0.5 W
	Connection supply	cable , 3 x 0.75 mm ²
Functional Data	Sensor Technology	Ultrasonic time-of-flight (with glycol and temperature compensation)
	Application	water
	Voltage output	1 x 0...10 V, max. load 1 mA
	Body Pressure Rating	360 psi
	Installation position	upright to horizontal
	Servicing	maintenance-free
	Velocity range	0.08-9.62 FPS
Measuring Data	Measured values	Flow
	Measuring fluid	Water and water-glycol mixtures
	Measuring principle	Ultrasonic volumetric flow measurement
	Measuring accuracy flow	±2% of the measured value (20...100% FS) @ 20°C / glycol 0% vol. ±0.4% of FS (0...20% FS) @ 20°C / glycol 0% vol.
	Measurement Repeatability	±0.5% (Flow)
	Min. flow measurement	1% of Max Flow
Materials	Fluid wetted parts	Brass nickel-plated
	Flow measuring pipe	brass body nickel-plated

Safety Data	Protection class IEC/EN	III, Safety Extra-Low Voltage (SELV)
	Power source UL	Class 2 Supply
	Degree of protection IEC/EN	IP54
	Degree of protection NEMA/UL	NEMA 2
	Enclosure	UL Enclosure Type 2
	Certification IEC/EN	IEC/EN 60730-1
	Quality Standard	ISO 9001
	UL Approval	cULus acc. to UL94
	Type of action	Type 1
	Rated impulse voltage supply	0.8 kV
	Pollution degree	3
	Ambient humidity	Max. 95% RH, non-condensing
	Ambient temperature	-22...122°F [-30...50°C]
	Fluid temperature	-5...250°F [-20...120°C]

Safety Notes

This device has been designed for use in stationary heating, ventilation and air-conditioning systems and must not be used outside the specified field of application, especially in aircraft or in any other airborne means of transport.

Outdoor applications: Only possible where (sea) water, snow, ice, sunlight or aggressive gases cannot interfere directly with the device and it can be guaranteed that the ambient conditions remain at all times within the thresholds according to the data sheet.

Only authorized specialists may carry out installation. All applicable legal or institutional installation regulations must be complied during installation.

The device contains electrical and electronic components and must not be disposed of as household refuse. All locally valid regulations and requirements must be observed.

Product Features

Mode of operation The ultrasonic flow sensor is equipped with a flow pipe, two flow transmitters and an electronic circuit. A temperature sensor is mounted in the flow pipe to compensate the temperature effects.

A sensor error occurs when the ultrasonic path is interrupted (air bubbles in the system, connection to ultrasonic transducers interrupted).

Patented glycol compensation Glycol changes the viscosity of the heat transfer fluid and as a result affects the measured volumetric flow. Without glycol compensation, volumetric flow measurements can show errors of as much as 30 percent. The patented automatic glycol compensation significantly reduces the degree of measurement error.

Installation notes

Recommended installation positions The sensor can be installed upright to horizontal. The sensor may not be installed in a hanging position.

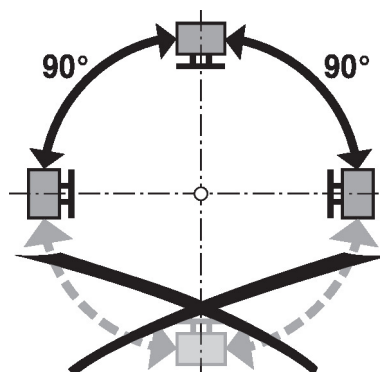

- Installation in return** Installation in the return is recommended.
- Inlet section** In order to achieve the specified measuring accuracy, a flow-calming section or inflow section in the direction of the flow is to be provided upstream from the flow sensor. Its dimensions should be at least 5x DN.
- Water quality requirements** The water quality requirements specified in VDI 2035 must be adhered to.
- Servicing** Sensors are maintenance-free.
 Before any service work on the sensor is carried out, it is essential to isolate the sensor from the power supply (by unplugging the electrical cables if necessary). Any pumps in the part of the piping system concerned must also be switched off and the appropriate slide valves closed (allow all components to cool down first if necessary and always reduce the system pressure to ambient pressure level).
 The system must not be returned to service until the sensor has been correctly reassembled in accordance with the instructions and the pipeline has been refilled by professionally trained personnel.
- Flow direction** The direction of flow, specified by an arrow on the housing, is to be complied with, since otherwise the flow rate will be measured incorrectly.

Wiring Diagram

Notes Supply from isolating transformer.

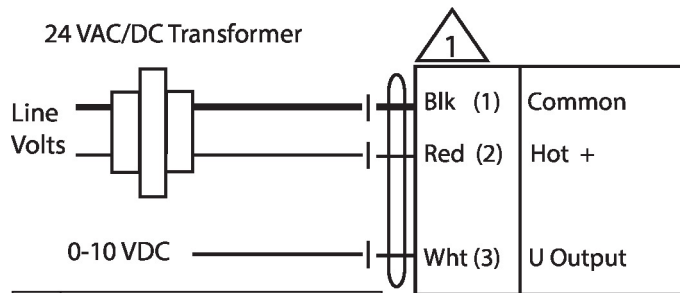

0 V	Sensor has no supply voltage
0.3 V	Sensor has supply voltage but is in error state
0.5 V	Zero and negative flow
10 V	Maximum flow

Dimensions

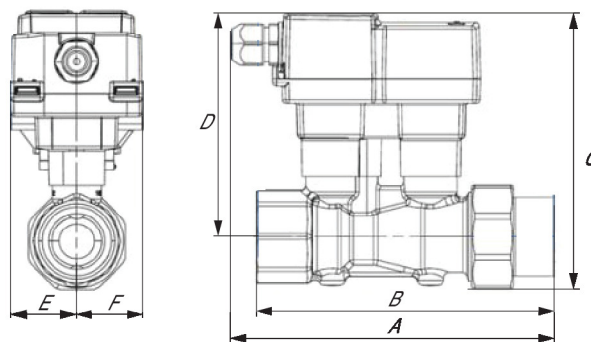

Type	DN	DN ["]	A_1	B_1	C_1	D_1	E_1	F_1	Weight
FM050	15	1/2	4.5" [114]	4.3" [108]	4.9" [124]	4.3" [110]	1.5" [39]	1.5" [39]	1.7 lb [0.750 kg]
FM075	20	3/4	5.1" [129]	4.6" [118]	5.1" [129]	4.4" [113]	1.5" [39]	1.5" [39]	1.9 lb [0.870 kg]
FM100	25	1	5.4" [136]	4.9" [125]	5.2" [132]	4.5" [115]	1.5" [39]	1.5" [39]	2.4 lb [1.1 kg]

Type	DN	DN ["]	A_1	B_1	C_1	D_1	E_1	F_1	Weight
FM125	32	1 1/4	5.5" [140]	5.0" [127]	5.6" [141]	4.6" [117]	1.5" [39]	1.5" [39]	2.8 lb [1.3 kg]
FM150	40	1 1/2	5.6" [143]	5.2" [131]	6.1" [154]	4.8" [122]	1.5" [39]	1.5" [39]	3.7 lb [1.7 kg]
FM200	50	2	5.9" [149]	5.4" [137]	6.5" [165]	5.0" [127]	1.5" [39]	1.5" [39]	4.6 lb [2.1 kg]