

ZoneTight™, 2-way, Press fit

- For closed cold and warm water systems
- For modulating control of air-handling and heating systems on the water side
- Snap-assembly of the actuator

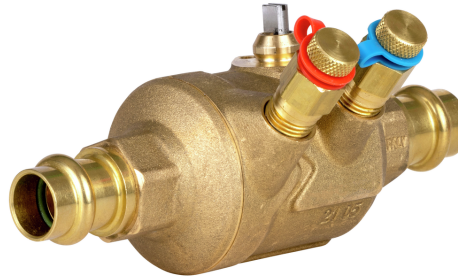

5-year warranty

Type overview

| | |
|-------------|-----------|
| Type | DN |
| Z2050QTPF-D | 15 |

Technical data

| | | |
|---------------------------|--------------------------|---|
| Functional data | Valve size [mm] | 0.5" [15] |
| | Fluid | chilled or hot water, up to 60% glycol |
| | Fluid Temp Range (water) | 36...212°F [2...100°C] |
| | Differential pressure | 5...50 psi |
| | Body Pressure Rating | 250 psi CWP |
| | Close-off pressure Δps | 200 psi |
| | Flow characteristic | equal percentage |
| | Angle of rotation note | Operating range 15...90° |
| | Pipe connection | Press fit |
| | Installation position | upright to horizontal (in relation to the stem) |
| | Servicing | maintenance-free |
| | Flow Pattern | 2-way |
| | Leakage rate | 0% |
| Controllable flow range | 75° | |
| Materials | Valve body | forged brass |
| | Stem | stainless steel |
| | Stem seal | EPDM O-ring |
| | Seat | PTFE, O-Ring EPDM |
| | Seat | PTFE |
| | Characterized disc | incorporated into the ball |
| | Diaphragm | EPDM |
| | O-ring | EPDM |
| Ball | stainless steel | |
| Suitable actuators | Non-Spring | CQB |
| | Electrical fail-safe | CQKB(X) |
| Terms | Abbreviations | V'nom = nominal flow with valve completely opened |
| | | V'max = maximum flow, set by the angle of rotation limitation on the actuator |

Safety notes



- **WARNING:** This product can expose you to lead which is known to the State of California to cause cancer and reproductive harm. For more information go to www.p65warnings.ca.gov
- If temperature exceeds 212°F operating range due to a boiler control failure the valve will safely contain the hot water but manufacturers product warranty becomes invalid. Valve and actuator replacement is at the expense of others.

Product features

Application The PIQCV zone valves with its pressure independent technology are suited for large commercial buildings where higher close-off and dynamic balancing is required. Common applications include unit ventilators, fan coil units, VAV reheat coils, fin tube casing, radiant panels and duct coils. The valve fits in space restricted areas and can be assembled without the use of tools.

Product features

- Mode of operation** The ball valve is adjusted by a rotary actuator. The actuator is controlled by a commercially available modulating or 3-point control system and moves the ball of the valve – the throttling device – to the position dictated by the control signal. Open the characterized control valve counterclockwise and close it clockwise.
- Flow characteristic** Equal percentage flow control is ensured by the special design of the ball.
- Constant flow volume** With a differential pressure of 16...350 kPa, a constant flow volume is achieved thanks to the integrated pressure regulating valve. Independently of the differential pressure through the valve, a valve authority of 1 is achieved. Even with pressure variations and in the partial load range, the flow rate remains constant with each respective opening position (angle of rotation) and ensures a steady control.

Installation notes

Recommended installation positions The ball valve can be installed upright to horizontal. The ball valve may not be installed in a hanging position, i.e. with the stem pointing downwards.

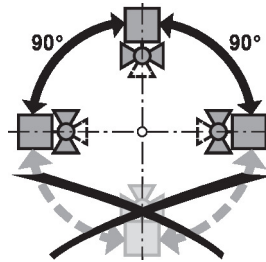

Water quality requirements Belimo valves are regulating devices. For the valves to function correctly in the long term, they must be kept free from particle debris (e.g. welding beads during installation work). The installation of a suitable strainer is recommended.

Servicing Ball valves and rotary actuators are maintenance-free.

Before any service work on the control element is carried out, it is essential to isolate the rotary actuator from the power supply (by unplugging the electrical cable if necessary). Any pumps in the part of the piping system concerned must also be switched off and the appropriate slide valves closed (allow all components to cool down first if necessary and always reduce the system pressure to ambient pressure level).

The system must not be returned to service until the ball valve and the rotary actuator have been correctly reassembled in accordance with the instructions and the pipeline has been refilled by professionally trained personnel.

Flow direction The direction of flow, specified by an arrow on the housing, is to be complied with, since otherwise the ball valve could become damaged. Please ensure that the ball is in the correct position (marking on the stem).

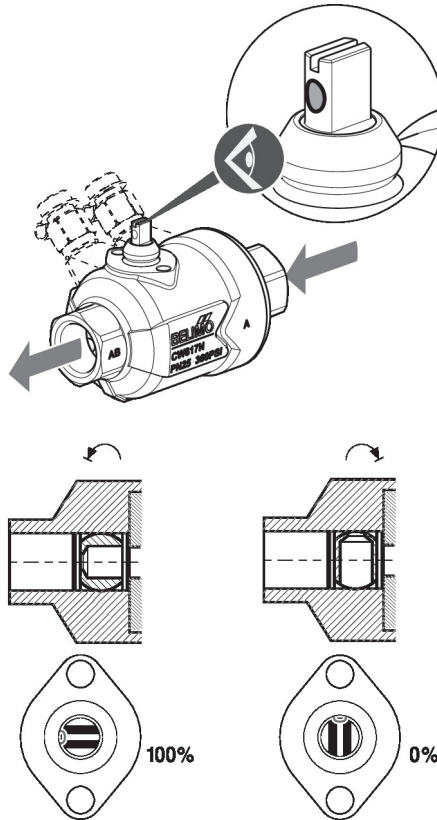

Flow setting The angle of rotation of the CQ.. actuator can be changed by end stop clip in 2.5° increments. This is used to set the V_{max} value (maximum flow rate of the valve).

Remove end stop clip and place at desired position.

After every change of the flow setting by means of end stop clip, an adaptation must be triggered on the modulating actuators.

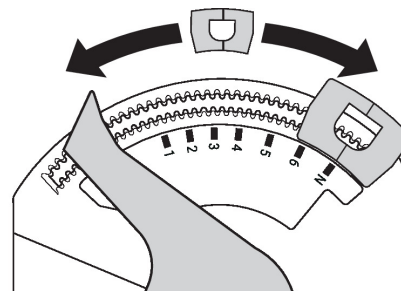

| | Pos | 1 | 2 | 3 | 3+ | 4- | 4 | 4+ | 5- | 5 | 5+ | 6- | 6 | 6+ | N- | N | |
|-------------|------------------------|-------|-------|-------|-------|-------|-------|-------|-------|-------|-------|-------|-------|-------|-------|-------|-------|
| | Bus | 41% | 49% | 56% | 60% | 63% | 66% | 68% | 71% | 74% | 77% | 79% | 82% | 85% | 88% | 91% | 100% |
| | ↙ | 37° | 44° | 51° | 54° | 57° | 59° | 61° | 64° | 67° | 69° | 71° | 74° | 77° | 79° | 82° | 90° |
| C215QP(T)-B | V _{max} (l/h) | 20 | 30 | 40 | 45 | 50 | 60 | 70 | 80 | 90 | 105 | 120 | 135 | 150 | 165 | 180 | 210 |
| | V _{max} (l/s) | 0.006 | 0.008 | 0.011 | 0.013 | 0.014 | 0.017 | 0.019 | 0.022 | 0.025 | 0.029 | 0.033 | 0.038 | 0.042 | 0.046 | 0.050 | 0.058 |
| C215QP(T)-D | V _{max} (l/h) | 50 | 70 | 100 | 110 | 130 | 150 | 170 | 190 | 210 | 240 | 270 | 300 | 330 | 360 | 400 | 420 |
| | V _{max} (l/s) | 0.014 | 0.019 | 0.028 | 0.031 | 0.036 | 0.042 | 0.047 | 0.053 | 0.058 | 0.067 | 0.075 | 0.083 | 0.092 | 0.100 | 0.111 | 0.117 |
| C220QP(T)-F | V _{max} (l/h) | 90 | 130 | 190 | 220 | 250 | 290 | 340 | 390 | 440 | 500 | 570 | 630 | 700 | 760 | 820 | 980 |
| | V _{max} (l/s) | 0.025 | 0.036 | 0.053 | 0.061 | 0.069 | 0.081 | 0.094 | 0.108 | 0.122 | 0.139 | 0.158 | 0.175 | 0.194 | 0.211 | 0.228 | 0.272 |
| C225QP(T)-G | V _{max} (l/h) | 260 | 410 | 600 | 670 | 750 | 840 | 920 | 1010 | 1110 | 1210 | 1310 | 1420 | 1530 | 1640 | 1750 | 2100 |
| | V _{max} (l/s) | 0.072 | 0.114 | 0.167 | 0.186 | 0.208 | 0.233 | 0.256 | 0.281 | 0.308 | 0.336 | 0.364 | 0.394 | 0.425 | 0.456 | 0.486 | 0.583 |



Dimensions

| Type | DN | Weight |
|-------------|----|------------------|
| Z2050QTPF-D | 15 | 1.76 lb [0.8 kg] |

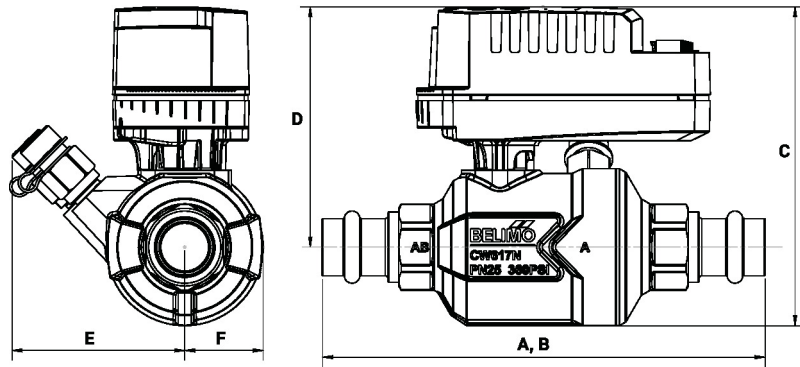

| A | B | C | D | E | F |
|------------|------------|------------|-----------|-----------|-----------|
| 5.9" [149] | 5.8" [148] | 4.3" [108] | 3.2" [82] | 2.4" [62] | 1.3" [33] |

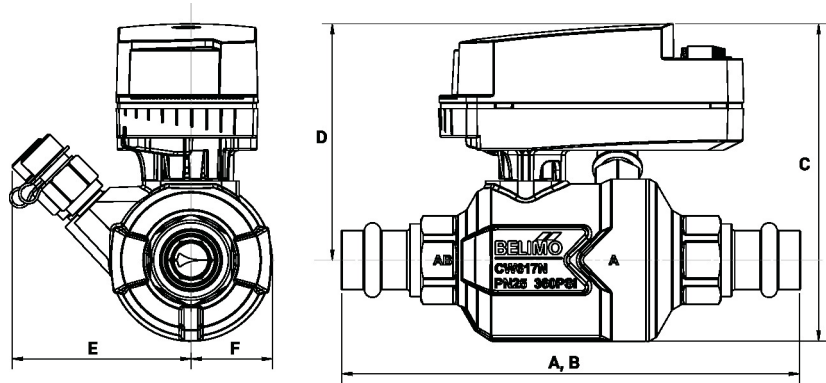

| A | B | C | D | E | F |
|------------|-----------|------------|-----------|-----------|-----------|
| 5.9" [149] | 3.8" [97] | 4.0" [101] | 3.0" [75] | 2.4" [62] | 1.3" [33] |