

- Nominal voltage AC/DC 24 V
- Control MFT/programmable
- Communication via Belimo MP-Bus or conventional control
- Conversion of active sensor signals and switching contacts

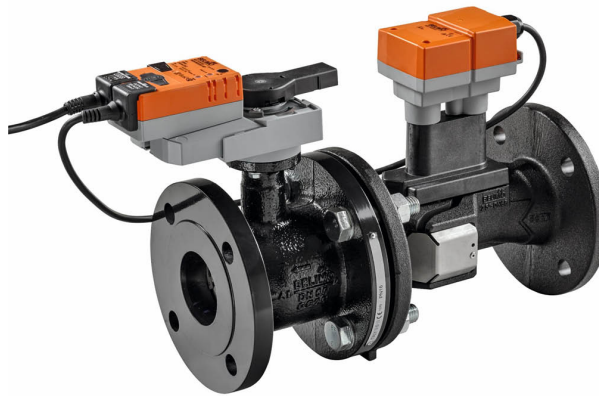

5-year warranty

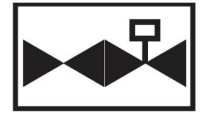

Technical data

<b>Electrical data</b>	Nominal voltage	AC/DC 24 V
	Nominal voltage frequency	50/60 Hz
	Power consumption in operation	11 W
<b>Data bus communication</b>	Number of nodes	Max. 32 (without repeater)
<b>Functional data</b>	Valve size [mm]	6" [150]
	Operating range Y	2...10 V
	Operating range Y note	4...20 mA w/ ZG-R01 (500 Ω, 1/4 W resistor)
	Input Impedance	100 kΩ (0.1 mA), 500 Ω
	Options positioning signal	VDC variable
	Position feedback U	2...10 V
	Position feedback U variable	VDC variable
	Running Time (Motor)	90 s
	Running time fail-safe	<35 s
	Sound power level Motor	52 dB(A)
	Noise level, fail-safe	61 dB(A)
	Control accuracy	±5%
	Min. controllable flow	1% of V'nom
	Fluid	chilled or hot water, up to 60% glycol max (open loop/steam not allowed)
	Fluid Temp Range (water)	14...250°F [-10...120°C]
	Close-off pressure Δps	310 psi
	Differential Pressure Range	5...50 psi or 1...50 psi see flow reductions chart in tech doc
	Flow characteristic	equal percentage or linear
	Body Pressure Rating	ANSI Class 250, standard class B, raised-face
GPM	713	
Servicing	maintenance-free	
Manual override	external push button	
<b>Flow measurement</b>	Measuring accuracy flow	±2%*
	Measurement Repeatability	±0.5% (Flow)
	Sensor Technology	Ultrasonic with glycol and temperature compensation
<b>Safety data</b>	Degree of protection IEC/EN	IP54
	Degree of protection NEMA/UL	NEMA 2
	Enclosure	UL Enclosure Type 2

<b>Safety data</b>	Agency Listing	cULus acc. to UL60730-1A/-2-14, CAN/CSA E60730-1:02, CE acc. to 2014/30/EU and 2014/35/EU; Listed to UL 2043 - suitable for use in air plenums per Section 300.22(c) of the NEC and Section 602.2 of the IMC
	Quality Standard	ISO 9001
	Ambient temperature	-22...122°F [-30...50°C]
	Storage temperature	-40...176°F [-40...80°C]
	Ambient humidity	Max. 95% RH, non-condensing
<b>Materials</b>	Valve body	Cast iron - GG 25
	Flow measuring pipe	Ductile cast iron - GGG50
	Spindle	stainless steel
	Spindle seal	EPDM (lubricated)
	Characterized disc	stainless steel
	Seat	PTFE
	Pipe connection	pattern to mate with ANSI 250 flange
	O-ring	EPDM (lubricated)
Ball	stainless steel	

**Safety notes**

- This device has been designed for use in stationary heating, ventilation and air-conditioning systems and must not be used outside the specified field of application, especially in aircraft or in any other airborne means of transport.
- Outdoor application: only possible in case that no (sea) water, snow, ice, insulation or aggressive gases interfere directly with the actuator and that is ensured that the ambient conditions remain at any time within the thresholds according to the data sheet.
- Only authorized specialists may carry out installation. All applicable legal or institutional installation regulations must be complied during installation.
- The device contains electrical and electronic components and must not be disposed of as household refuse. All locally valid regulations and requirements must be observed.

**Product features**

**Flow measurement** \*All flow tolerances are at 68°F [20°C] & water.

**Accessories**

Electrical accessories	Description	Type
	Replacement flow sensor for EPIV, electromagnetic	EPIVFS-60
	Service Tool, with ZIP-USB function, for programmable and communicative Belimo actuators, VAV controller and HVAC performance devices	ZTH US

**Electrical installation**

AC/DC 24 V, modulating

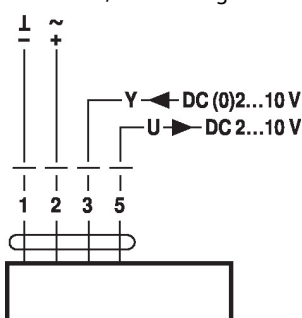

**Cable colors:**  
 1 = black  
 2 = red  
 3 = white  
 5 = orange

Operation on the MP-Bus

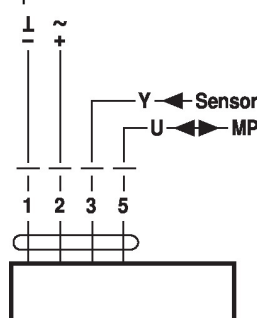

**Cable colors:**  
 1 = black  
 2 = red  
 3 = white  
 5 = orange

Control with 4...20 mA via external resistor

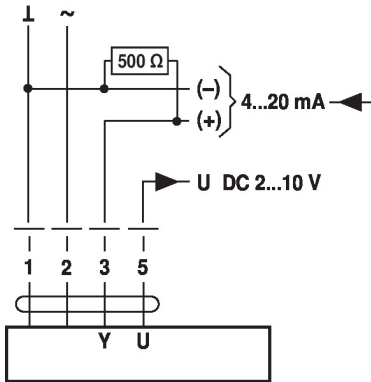

**Caution:**

The operating range must be set to DC 2...10 V.

The 500 Ohm resistor converts the 4...20 mA current signal to a voltage signal DC 2...10 V.

Connection of active sensors

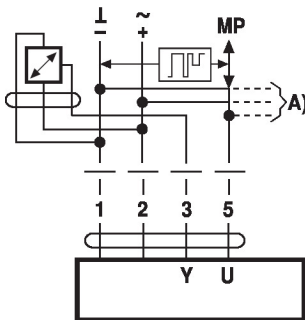

A) additional MP-Bus nodes (max. 8)

- Supply AC/DC 24 V
- Output signal DC 0...10 V (max. DC 0...32 V)
- Resolution 30 mV

### Functions

#### Functions when operated on MP-Bus

Connection on the MP-Bus

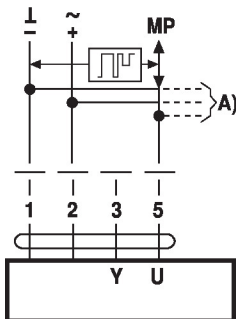

A) additional MP-Bus nodes (max. 8)

MP-Bus Network topology

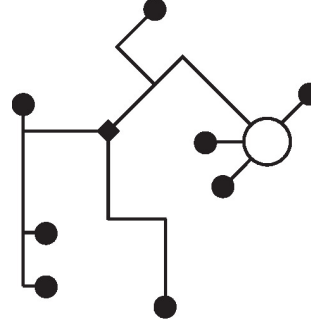

There are no restrictions for the network topology (star, ring, tree or mixed forms are permitted).

Supply and communication in one and the same 3-wire cable

- no shielding or twisting necessary
- no terminating resistors required

#### Functions with specific parameters (Parametrisation necessary)

Override control and limiting with AC 24 V with relay contacts

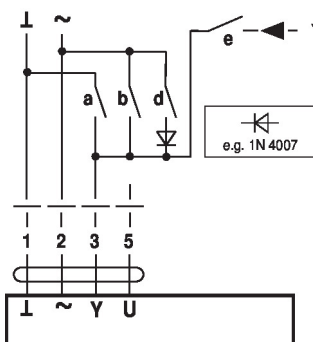

	a	b	d	e
Close	↗	↘	↗	↘
V <sub>max</sub>	↗	↘	↗	↘
Open	↘	↗	↘	↗
Y	↘	↗	↘	↗

Override control and limiting with DC 24 V with relay contacts

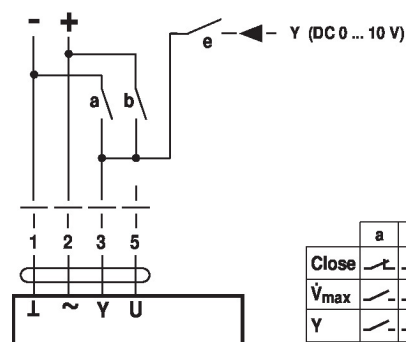

	a	b	d	e
Close	↗	↘	↗	↘
V <sub>max</sub>	↗	↘	↗	↘
Y	↘	↗	↘	↗

Control floating point

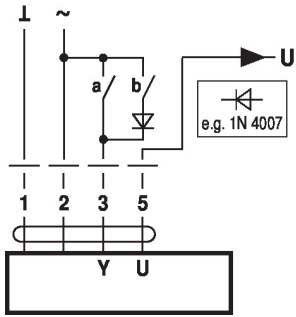

Position control: 90° = 100s  
 Flow control: Vmax = 100s

**Dimensions**

Dimensional drawings

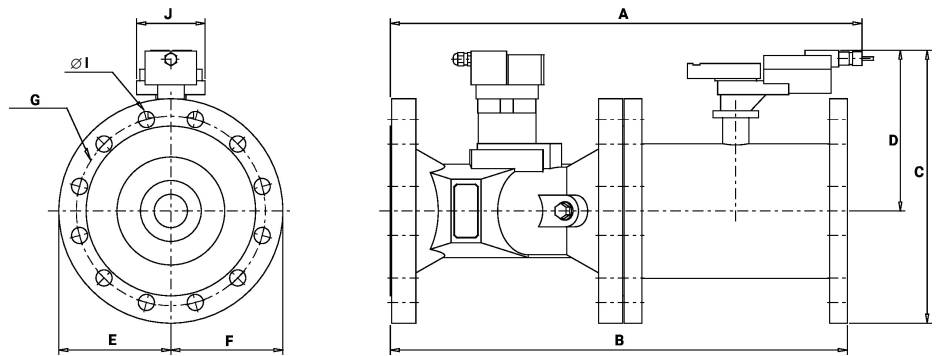

A	B	C	D	E	F	G	I	J
26.6" [675]	25.7" [653]	15.3" [389]	9.0" [229]	6.3" [160]	6.3" [160]	10.6" [270]	0.9" [22]	3.9" [100]