

986TC
EVOLUTION® TWO-STAGE, VARIABLE SPEED
4-WAY MULTIPOISE CONDENSING GAS FURNACE

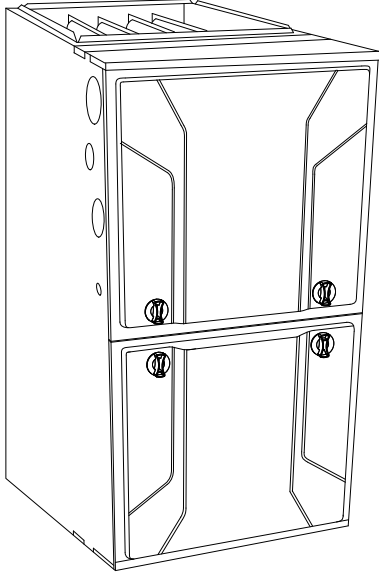

Product Data



A11264

The 986TC Multipoise Communicating, Variable-Speed Condensing Gas Furnace features the two-stage Evolution® System. The Perfect Heat Technology® two-stage gas system is at the heart of the comfort provided by this furnace, along with the Evolution variable-speed constant airflow ECM blower motor, and two-speed inducer motor. With an Annual Fuel Utilization Efficiency (AFUE) of up to 96.7%, the Evolution two-stage gas furnace provides exceptional savings when compared to a standard furnace. This Evolution Gas Furnace also features 4-way multipoise installation flexibility, and is available in five model sizes. The 986TC can be vented for direct vent/two-pipe, ventilated combustion air, or single-pipe applications. A Bryant Connex™ and Evolution Air Conditioner or Heat Pump can be used to form a complete Evolution System. Low NOx units are designed for California installations and meet 40 ng/J NOx emissions. Can be installed in air quality management districts with a 40 ng/J NOx emissions requirement. All sizes are design certified in Canada.

PERFORMANCE

- Communicating variable-speed, constant airflow (VCA) ECM blower motor for electrically efficient operation all year long in heating, cooling and continuous fan operation
- Two-speed inducer motor, and two-stage gas valve.
- Perfect Light™ Silicon Nitride Hot Surface Igniter.
- Adjustable blower speed for cooling, continuous fan, and dehumidification.
- Integral part of the Perfect Humidity System® Technology.
- SmartEvap™ technology helps control humidity levels in the home when used with a compatible humidity control system.
- Aluminized-steel primary heat exchanger.
- Stainless-steel condensing secondary heat exchanger.
- External Media Filter Cabinet included.
- Fully-insulated casing including blower section.
- Fan On Plus™ technology allows control of continuous fan speed from a compatible thermostat.

INSTALLATION FLEXIBILITY

- 4-way multipoise design for upflow, downflow or horizontal installation, with unique vent elbow and optional through-the-cabinet downflow venting capability.
- Ideal height 35-in. (889 mm) cabinet: short enough for taller coils, but still allows enough room for service.
- Direct-vent/sealed combustion, single-pipe venting or ventilated combustion air.

APPLICATIONS

- Self-diagnostics and extended diagnostic data through the Advanced Product Monitor (APM) accessory or Evolution Connex™ Interface.
- Propane convertible with gas conversion accessory
- Convenient Air Purifier and Humidifier connections.
- Compatible with single- and multiple-zone Evolution systems.

CERTIFICATIONS

- All sizes meet ENERGY STAR® Version 4.1 criteria for gas furnaces: 95%+ AFUE.
- Cabinet air leakage less than 2.0% at 1.0 in. W.C. and cabinet air leakage less than 1.4% at 0.5 in. W.C. when tested in accordance with ASHRAE standard 193.



Use of the AHRI Certified™ Mark indicates a manufacturer's participation in the program. For verification of certification for individual products, go to www.ahridirectory.org.



ISO 9001
Quality



FURNACE SIZE	CASING DIMENSIONS (IN.)			RATED HEATING OUTPUT† (BTUH)		AFUE		ENERGY STAR®	HEATING AIRFLOW			COOLING CFM @ 0.5 ESP	MOTOR HP (VARIABLE SPEED)	MEDIA CABINET SUPPLIED IN.(MM)	APPROX. SHIP WT. LB(KG)
	H	D	W	High	Low	UPFLOW/HORIZONTAL	DOWN-FLOW		CFM‡ (Low Heating)	CFM (High Heating)	Rated High Heating ESP				
42060C17	35	30	17.50	58,000	38,000	96.3%	95.0%	YES	755	1055	0.12	530 - 1280	1/2	16 (406)	151 (68.5)
42080C17	35	30	17.50	78,000	50,000	96.2%	95.0%	YES	1008	1240	0.15	520 - 1310	1/2	16 (406)	152.5 (69.2)
60080C21	35	30	21.00	78,000	51,000	96.7%	95.0%	YES	1095	1345	0.15	750 - 1945	1	20 (508)	171.5 (77.8)
66100C21	35	30	21.00	98,000	63,000	96.1%	95.0%	YES	1385	1575	0.20	715 - 2160	1	20 (508)	179 (81.2)
66120C24	35	30	24.50	117,000	76,000	96.7%	95.0%	YES	1555	1820	0.20	705 - 2135	1	24 (609)	195 (88.4)

† Capacity in accordance with DOE test procedures. Ratings are position dependent. See rating plate.

‡ Heating CFM with switch 1–4 OFF.

ESP – External Static Pressure

FEATURES AND BENEFITS

Perfect Heat Technology® feature — This feature with Adaptive Control is a proprietary function that promotes homeowner comfort through two stages of heating. This Bryant furnace offers a patented algorithm that continually monitors and adjusts furnace operation by looking at both current and past conditions to determine the most effective stage of heating and the amount of time to run each stage, every cycle.

Perfect Humidity System® Technology — The Perfect Humidity system actively controls both temperature and humidity in the home to provide the best comfort all year long. Other systems depend on heating or cooling demand to manage the moisture in the air. But, Perfect Humidity gives the homeowner the right amount of humidity day and night, even in mild weather. Perfect Humidity saves energy, too. By keeping humidity under control, the homeowner can set their thermostat lower to stay comfortable and save energy.

SmartEvap™ Technology — When paired with a compatible thermostat, this dehumidification feature overrides the cooling blower off-delay when there is a call for dehumidification. By deactivating the blower off-delay, SmartEvap technology prevents condensate that remains on the coil after a dehumidification cycle from re-humidifying throughout the home. This results in reduced humidity and a more comfortable indoor environment for the homeowner.

Unlike competitive systems, SmartEvap technology only overrides the cooling blower off-delay when humidity control is needed. Once humidity is back in control, SmartEvap re-enables the energy-saving cooling blower off-delay.

Fan On Plus™ Technology — Sometimes the constant fan setting on a standard furnace system can actually reduce homeowner comfort by providing too much or too little air! Fan On Plus technology improves comfort all year long by allowing the homeowner to select the continuous fan speed of their choice using a compatible thermostat.

HYBRID HEAT® Dual Fuel System — This system can provide more control over your monthly energy bills by automatically selecting the most economical method of heating. With HYBRID HEAT components, our system automatically switches between the gas furnace and the electric heat pump as outside temperatures change to maintain greater efficiency and comfort than with any traditional single-source heating system. The heat pump also delivers high-efficiency cooling in the summer.

Perfect Light™ Igniter — Bryant's unique SiN igniter is not only physically robust but it is also electrically robust. It is capable of running at line voltage and does not require complex voltage regulators as do other brands. This unique feature further enhances the gas furnace reliability and continues Bryant's tradition of technology leadership and innovation in providing a reliable and durable product.

Full-Featured, Communicating, Variable Speed Motors — Our ECMs (Electronically Commutated Motors) provide variable-speed operation to optimize comfort levels in the home year round; features such as passive/active dehumidification, ramping profiles, constant air flow and quiet operation. They can provide cooling

match enhancements to increase the effective SEER of select Bryant air conditioner or heat pump system, and feature the highest efficiency of all indoor fan motors.

Reliable Heat Exchanger Design — The aluminized steel, clam shell primary heat exchanger was re-engineered to achieve greater efficiency out of a smaller size. The first two passes of the heat exchanger are based on the current 80% product, a design with more than ten years of field-proven performance and success. These innovations, paired with the continuation of a crimped, no-weld seam create an efficient, robust design for this essential component.

The condensing heat exchanger, a stainless steel fin and tube design, is positioned in the furnace to extract additional heat. Stainless steel coupling box componentry between heat exchangers has exceptional corrosion resistance in both natural gas and propane applications.

Media Filter Cabinet — Enhanced indoor air quality in the home is made easier with our media filter cabinet—a standard accessory on all deluxe furnaces. When installed as a part of the system, this cabinet allows for easy and convenient addition of a Bryant high efficiency air filter.

4-Way Multipoise Design — One model for all applications — there is no need to stock special downflow or horizontal models when one unit will do it all.

Direct or Single-pipe Venting, or Optional Ventilated Combustion Air — This furnace can be installed as a 2-pipe (Direct Vent) furnace, in an optional ventilated combustion air application, or in single-pipe, non-direct vent applications. This provides added flexibility to meet diverse installation needs.

Sealed Combustion System — This furnace brings in combustion air from outside the furnace, which results in especially quiet operation. By sealing the entire combustion vestibule, the entire furnace can be made quieter, not just the burners.

Insulated Casing — Foil-faced insulation in the heat exchanger section of the casing minimizes heat loss. The acoustical insulation in the blower compartment reduces air and motor noise for quiet operation.

Monoport Burners — The burners are specially designed and finely tuned for smooth, quiet combustion and economical operation.

Bottom Closure — Factory-installed for side return; easily removable for bottom return. The multi-use bottom closure can also serve for roll-out protection in horizontal applications, and act as the bottom closure for the optional return air base accessory.

Blower Access Panel Switch — Automatically shuts off 115-v power to furnace whenever blower access panel is opened.

Quality Registration — Our furnaces are engineered and manufactured under a quality management system registered to ISO 9001.

Certifications — This furnace is CSA (AGA and CGA) design certified for use with natural and propane gases. The furnace is factory-shipped for use with natural gas. A CSA listed gas conversion kit is required to convert furnace for use with propane gas. The efficiency is AHRI efficiency rating certified.

SPECIFICATIONS

The furnace should be sized to provide 100 percent of the design heating load requirement plus any margin that occurs because of furnace model size capacity increments. None of the furnace model sizes can be used if the heating load is 20,000 BTU or lower. Use Air Conditioning Contractors of America (Manual J and S); American Society of Heating, Refrigerating, and Air-Conditioning Engineers; or other approved engineering

method to calculate heating load estimates and select the furnace. Excessive oversizing of the furnace may cause the furnace and/or vent to fail prematurely, customer discomfort and/or vent freezing. Failure to follow these guidelines is considered faulty installation and/or misapplication of the furnace; and resulting failure, damage, or repairs may impact warranty coverage.

Heating Capacity and Efficiency			42060C17	42080C17	60080C21	66100C21	66120C24
Input	High Heat	(BTUH)	60,000	80,000	80,000	100,000	120,000
	Low Heat	(BTUH)	39,000	52,000	52,000	65,000	78,000
Output	High Heat	(BTUH)	58,000	78,000	78,000	98,000	117,000
	Low Heat	(BTUH)	38,000	50,000	51,000	63,000	76,000
Certified Temperature Rise Range °F (°C)	High Heat		35 - 65 (19 - 36)	40 - 70 (22 - 39)	40 - 70 (22 - 39)	45 - 75 (25 - 42)	45 - 75 (25 - 42)
	Low Heat		30 - 60 (17 - 33)	30 - 60 (17 - 33)	30 - 60 (17 - 33)	30 - 60 (17 - 33)	30 - 60 (17 - 33)
Airflow Capacity and Blower Data							
Rated External Static Pressure (in. w.c.)	Heating		0.12	0.15	0.15	0.20	0.20
	Cooling		0.50	0.50	0.50	0.50	0.50
Airflow Delivery @ Rated ESP (CFM)	High Heat		1055	1240	1345	1575	1820
	Low Heat		755	1008	1095	1385	1555
	Cooling		1280	1310	1945	2160	2135
Cooling Capacity (tons)	400 CFM/ton		3	3.50	4.50	5	5.50
	350 CFM/ton		3.50	4	5.50	6	6
Direct-Drive Motor Type	Electronically Commutated Motor (ECM)						
Direct-Drive Motor HP			1/2	1/2	1	1	1
Motor Full Load Amps			8.50	8.50	12.80	12.80	12.80
RPM Range	300 - 1300						
Speed Selections	Variable (Communicating)						
Blower Wheel Dia x Width	in.		11 x 8	11 x 8	11x10	11 x 10	11 x 11
Air Filtration System	Factory Supplied External Media Cabinet Field Supplied Filter						
Filter Used for Certified Watt Data*	KGAWF**06UFR						
Electrical Data							
Input Voltage	Volts-Hertz-Phase		115-60-1				
Operating Voltage Range	Min-Max		104-127				
Maximum Input Amps	Amps		9.30	9.30	13.60	13.70	13.70
Unit Ampacity	Amps		12.60	12.60	17.90	18.00	18.00
Minimum Wire Size	AWG		14	14	12	12	12
Maximum Wire Length @ Minimum Wire Size	Feet		29	29	32	31	31
	(M)		(9.0)	(9.0)	(9.8)	(9.7)	(9.7)
Maximum Fuse/Ckt Bkr (Time-Delay Type Recommended)	Amps		15	15	20	20	20
Transformer Capacity (24vac output)	40 VA						
External Control Power Available	Heating		24.3 VA				
	Cooling		34.6 VA				
Controls							
Gas Connection Size	1/2" - NPT						
Burners (Monoport)			3	4	4	5	6
Gas Valve (Redundant)	Manufacturer	White Rogers					
	Minimum Inlet Gas pressure (in. wc)	4.50					
	Maximum Inlet Gas pressure (in. wc)	13.60					
Manufactured (Mobile) Home Kit	<i>not approved for MH use</i>						
Ignition Device	Silicon Nitride						
Heating Blower Control (Heating Off-Delay)	Adjustable: 90, 120, 150, 180 seconds						
Cooling Blower Control (Time Delay Relay)	90 seconds						
Communication System	Evolution; Evolution Zoning						
Thermostat Connections	R, W/W1, W2 Y/Y2, Y1, G, Com 24V, DHUM						
Accessory Connections	EAC (115vac); HUM (24vac); 1-stg AC (via Y/Y2)						

* See Accessory List for part numbers available.

MODEL NUMBER NOMENCLATURE

1 Heat Exchanger	2 Tier/NOx	3 AFUE/NOx	4 Heating Stages	5 Major Series	6, 7 Cooling Capacity (CFM)	8 - 10 Heat Input	11 Motor Type	12 - 13 Width	14 Voltage (1-phase)	15 Un-used	16 Minor Series
9	8	7	M	B	42	060	C	17	A	-	A
8 = 80% 9 = 90+%	0 = Base 1 = Legacy Line 2 = Preferred 3 = Ultra Low Nox 8 = Evolution	0 = 80% 1 = 80% Low Nox --- 2 = 92% 5 = 95% 6 = 96% 7 = 97% 8 = 98%	M = Modulating S = Single Stage T = Two-Stage	A B C D ---	24 = 800 CFM 30 = 1000 CFM 36 = 1200 CFM 42 = 1400 CFM 48 = 1800 CFM 60 = 2000 CFM 66 = 2200 CFM	026 = 26,000 BTU/h 040 = 40,000 BTU/h 060 = 60,000 BTU/h ---	G = Comm. Variable-Speed Constant Airflow (VCA) ECM E = Fixed-Speeds Constant Torque (FCT) ECM V = Variable-Speed Constant Torque (VCT) ECM	14 = 14.2" 17 = 17.5" 21 = 21.0" 24 = 24.5"	A = 110V/60Hz B = 230V/50Hz	-	A B C ---

A190042

For California Residents:

For installation in SCAQMD only: This furnace does not meet the SCAQMD Rule 1111 14 ng/J NOx emission limit, and thus is subject to a mitigation fee of up to \$450. This furnace is not eligible for the Clean Air Furnace Rebate Program: www.CleanAirFurnaceRebate.com

FURNACE COMPONENTS

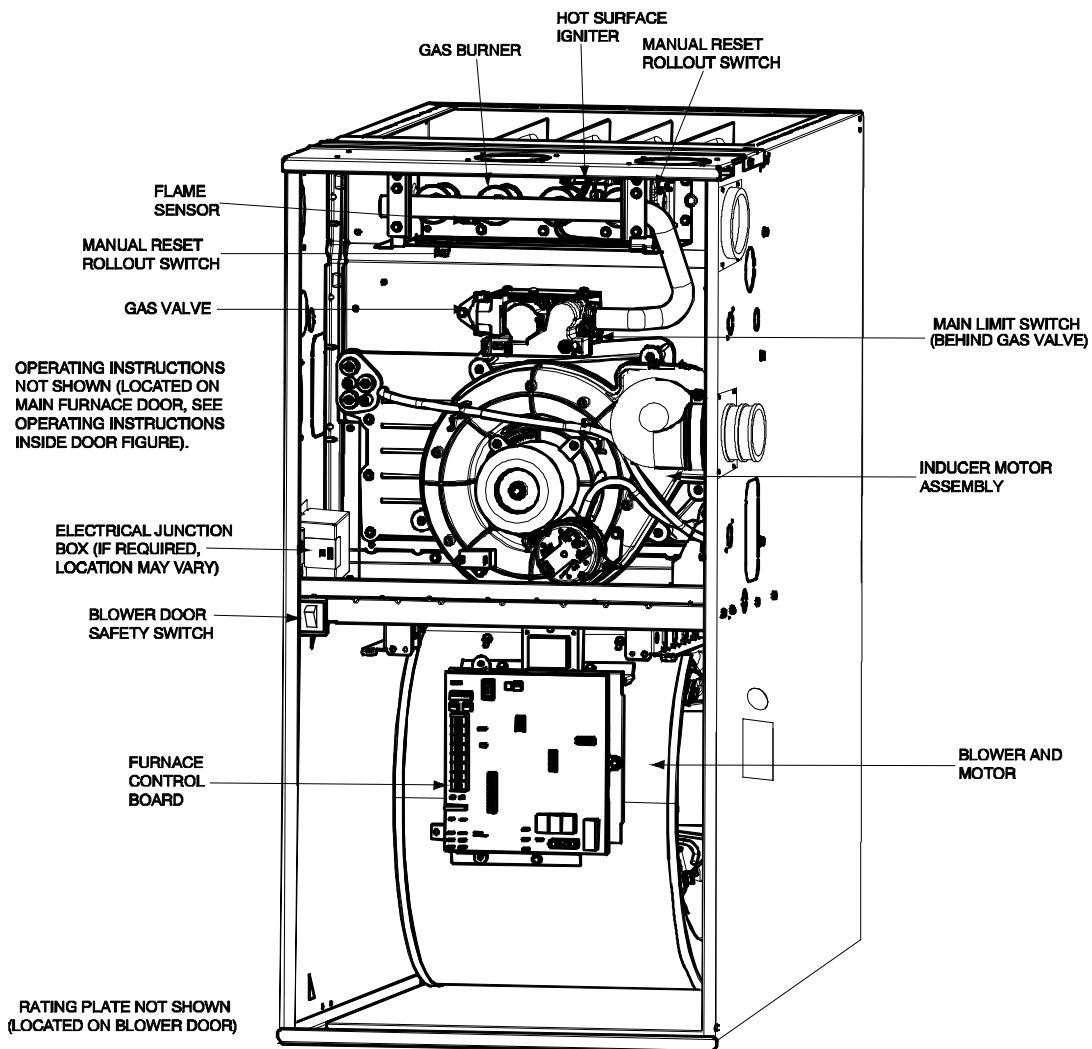

A190145

ACCESSORIES

DESCRIPTION	PART NUMBER	42060C17	42080C17	60080C21	66100C21	66120C24
Vent Kit - Through the Cabinet	KGADC0101BVC	●	●	●	●	●
Vent Terminal - Concentric - 2" (51 mm)	KGAVT0701CVT	See Venting Tables				
Vent Terminal - Concentric - 3" (76 mm)	KGAVT0801CVT					
Vent Terminal Bracket - 2" (51 mm)	KGAVT0101BRA					
Vent Terminal Bracket - 3" (76 mm)	KGAVT0201BRA					
Vent Kit – Rubber Coupling	KGAAC0101RVC					
Freeze Protect Kit - Condensate Drain Line Tape	KGAHT0101CFP	●	●	●	●	●
Freeze Protect Kit - Condensate Trap with Heat Pad	KGAHT0201CFP	●	●	●	●	●
CPVC to PVC Drain Adapters - 1/2" CPVC to 3/4" PVC	KGAAD0110PVC	●	●	●	●	●
Horizontal Trap Grommet - Direct Vent	KGACK0101HCK	All 2-Pipe Horizontal				
Condensate Neutralizer Kit	P908-0001	●	●	●	●	●
External Trap Kit	KGBET0201ETK	●	●	●	●	●
Downflow Furnace Base Kit for Combustible Floors	KGASB0201ALL	●	●	●	●	●
Coil Adapter Kits – No Offset	KGADA0101ALL	●	●	●	●	●
Coil Adapter Kits – Single Offset	KGADA0201ALL	●	●	●	●	●
Coil Adapter Kits – Double Offset	KGADA0301ALL	●	●	●	●	●
Return Air Base (Upflow Applications) 17.5-in. wide	KGARP0301B17	●	●			
Return Air Base (Upflow Applications) 21.0-in. wide	KGARP0301B21			●	●	
Return Air Base (Upflow Applications) 24.5-in. wide	KGARP0301B24					●
IAQ Device Duct Adapters 20.0-in. IAQ to 16 in. Side Return	KGAAD0101MEC	20"x25" IAQ Devices				
IAQ Device Duct Adapters 24.0-in. IAQ to 16 in. Side Return	KGAAD0201MEC	24"x25" IAQ Devices				
Gas Conversion Kit - Nat to LP	AGAGC9NPS01A	●	●	●	●	●
Gas Conversion Kit - LP to Nat	AGAGC9PNS01A	●	●	●	●	●
Gas Valve Tower Port Adapter Kit	92-1003	●	●	●	●	●
Bottom Filter Rack – 17.5 inches (455 mm)	KGBFR0501B17	●	●			
Bottom Filter Rack – 21 inches (533 mm)	KGBFR0601B21			●	●	
Bottom Filter Rack – 24.5 inches (622 mm)	KGBFR0701B24					●
Filter Pack (6 pack) – Washable - 16x25x1 (406x635x25 mm)	KGAWF1306UFR	●	●			
Filter Pack (6 pack) – Washable - 24x25x1 (610x635x25 mm)	KGAWF1506UFR			●	●	●

● = Used with the model furnace

DESCRIPTION		
Gas Orifice Kit - #42 (Nat Gas)	LH32DB207	See Installation Instructions for model, altitude, and heat value usages.
Gas Orifice Kit - #43 (Nat Gas)	LH32DB202	
Gas Orifice Kit - #44 (Nat Gas)	LH32DB200	
Gas Orifice Kit - #45 (Nat Gas)	LH32DB205	
Gas Orifice Kit - #46 (Nat Gas)	LH32DB208	
Gas Orifice Kit - #47 (Nat Gas)	LH32DB078	
Gas Orifice Kit - #48 (Nat Gas)	LH32DB076	
Gas Orifice Kit - #54 (LP)	LH32DB203	
Gas Orifice Kit - #55 (LP)	LH32DB201	
Gas Orifice Kit - #56 (LP)	LH32DB206	
Gas Orifice Kit - 1.25mm (LP)	LH32DB209	
Gas Orifice Kit - 1.30mm (LP)	LH32DB210	

ACCESSORIES (CONTINUED)

DESCRIPTION	ACCESSORY			
HUMIDIFIER	Model HUM			
HEAT RECOVERY VENTILATOR	Model HRV			
ENERGY RECOVERY VENTILATOR	Model ERV			
UV LIGHTS	Model UVL			
DESCRIPTION	ACCESSORY	17"	21"	24"
Bryant Carbon Monoxide Alarm (10 pack)	COALMBBNRB02 – A10	X	X	X
Bryant Evolution Air Purifier - 16x25 (407x635 mm)	DGAPAXX1625	X		
Bryant Evolution Air Purifier - 20x25 (508x635 mm)	DGAPAXX2025		X	X
Bryant Evolution Air Purifier Repl. Filter- 16x25 (407x635 mm)	PGAPXCAR1625A02	X		
Bryant Evolution Air Purifier Repl. Filter- 20x25 (508x635 mm)	PGAPXCAR2025A02		X	X
Cartridge Media Filter - 16" (407 mm) (MERV 11)	FILXXCAR0116	X		
Cartridge Media Filter - 16" (407 mm) (MERV 8)	FILXXCAR0016	X		
Cartridge Media Filter - 20" (508 mm) (MERV 8)	FILXXCAR0020		X	
Cartridge Media Filter - 20" (508 mm) (MERV11)	FILXXCAR0120		X	
Cartridge Media Filter - 24" (610 mm) (MERV 8)	FILXXCAR0024			X
Cartridge Media Filter - 24" (610 mm) (MERV11)	FILXXCAR0124			X
EZ Flex Cabinet Side or Bottom – 16"	EZXCAB – –0016	X		
EZ Flex Cabinet Side or Bottom – 20"	EZXCAB – –0020		X	X
EZ Flex Replacement Filters 16" MERV 10	EXPXXFIL0016	X		
EZ Flex Replacement Filters 16" MERV 13	EXPXXFIL0316	X		
EZ Flex Replacement Filters 20" MERV 10	EXPXXFIL0020		X	
EZ Flex Replacement Filters 20" MERV 13	EXPXXFIL0320		X	
EZ Flex Replacement Filters 24" MERV 10	EXPXXFIL0024			X
EZ Flex Replacement Filters 24" MERV 13	EXPXXFIL0324			X
EZ-Flex Filter with End Caps - 16" (407 mm) (MERV 10)	EXPXXUNV0016	X		
EZ-Flex Filter with End Caps - 16" (407 mm) (MERV 13)	EXPXXUNV0316	X		
EZ-Flex Filter with End Caps - 20" (508 mm) (MERV 10)	EXPXXUNV0020		X	
EZ-Flex Filter with End Caps - 20" (508 mm) (MERV 13)	EXPXXUNV0320		X	
EZ-Flex Filter with End Caps - 24" (610 mm) (MERV 10)	EXPXXUNV0024			X
EZ-Flex Filter with End Caps - 24" (610 mm) (MERV 13)	EXPXXUNV0324			X
Media Filter Cabinet – 20"	FILCABXL0020		X	
Media Filter Cabinet – 24"	FILCABXL0024			X
Media Filter Cabinet – 16"	FILCABXL0016	X		

● = Used with the model furnace

AIR DELIVERY

COOLING⁴ AND HEATING AIR DELIVERY - CFM (Bottom Return⁵ With Filter)

(SW1 – 5 and SW4 – 3 set to OFF, except as indicated. See notes 1 and 2.)

Unit Size: 42060C17	Clg/CF Switch settings			External Static Pressure (ESP)									
Clg Switches	SW2–3	SW2–2	SW2–1	0.1	0.2	0.3	0.4	0.5	0.6	0.7	0.8	0.9	1.0
Clg Default:	OFF	OFF	OFF	1115	1120	1125	1120	1120	1115	1110	1100	1095	1085
CF Switches	SW3–3	SW3–2	SW3–1										
Low–Clg Default:	OFF	OFF	OFF	565	565	555	540	530	See note 4				
Cooling Airflow (SW2) Low–Cooling Airflow (SW3)	OFF	OFF	ON	565	565	555	540	530	See note 4				
	OFF	ON	OFF	695	710	715	710	705	700	695	685	680	675
	OFF	ON	ON	940	945	940	935	935	930	920	900	890	875
	ON	OFF	OFF	1115	1120	1125	1120	1120	1115	1110	1100	1095	1085
	ON	OFF	ON	1285	1290	1295	1295	1285	1250	1220	1185	1155	1120
	ON	ON	OFF	1400	1370	1340	1310	1280	1245	1215	1185	1150	1115
	ON	ON	ON	1400	1370	1340	1310	1280	1245	1215	1185	1150	1115
Maximum Clg Airflow ²				1400	1370	1340	1310	1280	1245	1215	1185	1150	1115
CF Switches	SW3–3	SW3–2	SW3–1										
Cont. Fan Default:	OFF	OFF	OFF	565	565	555	540	530	See note 4				
Continuous Fan Airflow (SW3)	OFF	OFF	ON	565	565	555	540	530	See note 4				
	OFF	ON	OFF	695	710	715	710	705	700	695	685	680	675
	OFF	ON	ON	940	945	940	935	935	930	920	900	890	875
	ON	OFF	OFF	1115	1120	1125	1120	1120	1115	1110	1100	1095	1085
	ON	OFF	ON	1115	1120	1125	1120	1120	1115	1110	1100	1095	1085
	ON	ON	OFF	1115	1120	1125	1120	1120	1115	1110	1100	1095	1085
	ON	ON	ON	1115	1120	1125	1120	1120	1115	1110	1100	1095	1085
Heating (SW1)	High Heat Airflow ³			1055	1060	1065	1065	1055	1050	1040	1035	1025	1010
	Low Heat Airflow ³			750	770	775	775	770	765	755	745	740	735

Unit Size: 42080C17	Clg/CF Switch settings			External Static Pressure (ESP)									
Clg Switches	SW2–3	SW2–2	SW2–1	0.1	0.2	0.3	0.4	0.5	0.6	0.7	0.8	0.9	1.0
Clg Default:	OFF	OFF	OFF	1085	1095	1095	1100	1100	1095	1090	1095	1085	1080
CF Switches	SW3–3	SW3–2	SW3–1										
Low–Clg Default:	OFF	OFF	OFF	550	550	545	535	520	See note 4				
Cooling Airflow (SW2) Low–Cooling Airflow (SW3)	OFF	OFF	ON	550	550	545	535	520	See note 4				
	OFF	ON	OFF	705	710	710	710	700	See note 4				
	OFF	ON	ON	885	900	910	910	910	905	900	895	885	875
	ON	OFF	OFF	1085	1095	1095	1100	1100	1095	1090	1095	1085	1080
	ON	OFF	ON	1255	1265	1265	1270	1275	1275	1255	1220	1190	1160
	ON	ON	OFF	1420	1410	1375	1345	1310	1280	1255	1220	1190	1160
	ON	ON	ON	1420	1410	1375	1345	1310	1280	1255	1220	1190	1160
Maximum Clg Airflow ²				1445	1410	1375	1345	1310	1275	1255	1220	1190	1160
CF Switches	SW3–3	SW3–2	SW3–1										
Cont. Fan Default:	OFF	OFF	OFF	550	550	545	535	520	See note 4				
Continuous Fan Airflow (SW3)	OFF	OFF	ON	430	410	390	370	350	See note 4				
	OFF	ON	OFF	485	475	455	440	420	See note 4				
	OFF	ON	ON	550	550	545	535	520	See note 4				
	ON	OFF	OFF	550	550	545	535	520	See note 4				
	ON	OFF	ON	550	550	545	535	520	See note 4				
	ON	ON	OFF	550	550	545	535	520	See note 4				
	ON	ON	ON	550	550	545	535	520	See note 4				
Heating (SW1)	High Heat Airflow ³			1235	1245	1250	1255	1255	1260	1255	1220	1190	1160
	Low Heat Airflow ³			1005	1010	1015	1015	1020	1000	995	990	980	970

*See Notes following table.

AIR DELIVERY (CONTINUED)

COOLING⁴ AND HEATING AIR DELIVERY - CFM (Bottom Return⁵ With Filter)

(SW1–5 and SW4–3 set to OFF, except as indicated. See notes 1 and 2.)

Unit size: 60080C21	Clg/CF Switch settings			External Static Pressure (ESP)									
Clg Switches	SW2–3	SW2–2	SW2–1	0.1	0.2	0.3	0.4	0.5	0.6	0.7	0.8	0.9	1.0
Clg Default:	OFF	OFF	OFF	1745	1755	1755	1760	1755	1750	1745	1725	1705	1685
CF Switches	SW3–3	SW3–2	SW3–1										
Low–Clg Default:	OFF	OFF	OFF	700	710	750	725	750	See note 4				
Cooling Airflow (SW2) Low–Cooling Airflow (SW3)	OFF	OFF	ON	700	710	750	725	750	See note 4				
	OFF	ON	OFF	830	860	870	890	960	See note 4				
	OFF	ON	ON	1045	1045	1060	1070	1070	1070	1095	1090	1080	1070
	ON	OFF	OFF	1215	1220	1245	1240	1235	1235	1225	1220	1235	1235
	ON	OFF	ON	1370	1370	1390	1390	1400	1395	1400	1390	1390	1385
	ON	ON	OFF	1745	1755	1755	1760	1755	1750	1745	1725	1705	1685
	ON	ON	ON	1745	1755	1755	1760	1755	1750	1745	1725	1705	1685
Maximum Clg Airflow ²				1920	1920	1945	1945	1945	1960	1950	1940	1915	1900
CF Switches	SW3–3	SW3–2	SW3–1										
Cont. Fan Default:	OFF	OFF	OFF	700	710	750	725	750	See note 4				
Continuous Fan Airflow (SW3)	OFF	OFF	ON	700	710	750	725	750	See note 4				
	OFF	ON	OFF	830	860	870	890	960	See note 4				
	OFF	ON	ON	1045	1045	1060	1070	1070	1070	1095	1090	1080	1070
	ON	OFF	OFF	1215	1220	1245	1240	1235	1235	1225	1220	1235	1235
	ON	OFF	ON	1215	1220	1245	1240	1235	1235	1225	1220	1235	1235
	ON	ON	OFF	1215	1220	1245	1240	1235	1235	1225	1220	1235	1235
	ON	ON	ON	1215	1220	1245	1240	1235	1235	1225	1220	1235	1235
Heating (SW1)	High Heat Airflow ³			1340	1355	1370	1385	1380	1385	1400	1400	1385	1380
	Low Heat Airflow ³			1080	1115	1115	1120	1125	1135	1125	1120	1125	1110

Unit size: 66100C21	Clg/CF Switch settings			External Static Pressure (ESP)									
Clg Switches	SW2–3	SW2–2	SW2–1	0.1	0.2	0.3	0.4	0.5	0.6	0.7	0.8	0.9	1.0
Clg Default:	OFF	OFF	OFF	1820	1825	1840	1845	1840	1835	1825	1805	1780	1770
CF Switches	SW3–3	SW3–2	SW3–1										
Low–Clg Default:	OFF	OFF	OFF	750	740	745	730	715	See note 4				
Cooling Airflow (SW2) Low–Cooling Airflow (SW3)	OFF	OFF	ON	750	740	745	730	715	See note 4				
	OFF	ON	OFF	900	900	915	910	905	See note 4				
	OFF	ON	ON	1070	1075	1095	1095	1090	1085	1095	1080	1065	1070
	ON	OFF	OFF	1280	1285	1305	1305	1310	1305	1295	1300	1290	1285
	ON	OFF	ON	1440	1445	1465	1465	1470	1485	1480	1485	1475	1460
	ON	ON	OFF	1820	1825	1840	1845	1840	1835	1825	1805	1780	1770
	ON	ON	ON	2135	2140	2140	2135	2140	2130	2115	2100	2070	2015
Maximum Clg Airflow ²				2160	2165	2175	2170	2160	2150	2135	2120	2065	2020
CF Switches	SW3–3	SW3–2	SW3–1										
Cont. Fan Default:	OFF	OFF	OFF	750	740	745	730	715	See note 4				
Continuous Fan Airflow (SW3)	OFF	OFF	ON	750	740	745	730	715	See note 4				
	OFF	ON	OFF	900	900	915	910	905	See note 4				
	OFF	ON	ON	1070	1075	1095	1095	1090	1085	1095	1080	1065	1070
	ON	OFF	OFF	1070	1075	1095	1095	1090	1085	1095	1080	1065	1070
	ON	OFF	ON	1070	1075	1095	1095	1090	1085	1095	1080	1065	1070
	ON	ON	OFF	1070	1075	1095	1095	1090	1085	1095	1080	1065	1070
	ON	ON	ON	1070	1075	1095	1095	1090	1085	1095	1080	1065	1070
Heating (SW1)	High Heat Airflow ³			1570	1575	1595	1595	1600	1605	1600	1600	1590	1575
	Low Heat Airflow ³			1365	1385	1395	1395	1395	1400	1400	1405	1395	1380

*See Notes following table.

AIR DELIVERY (CONTINUED)

Cooling⁴ and Heating Air Delivery - CFM continued (Bottom Return⁵ with Filter)

(SW1-5 and SW4-3 set to OFF, except as indicated. See notes 1 and 2.)

Unit size: 66120C24	Cig/CF Switch settings			External Static Pressure (ESP)									
Cig Switches	SW2-3	SW2-2	SW2-1	0.1	0.2	0.3	0.4	0.5	0.6	0.7	0.8	0.9	1.0
Cig Default:	OFF	OFF	OFF	1845	1840	1835	1835	1825	1820	1810	1800	1785	1775
CF Switches	SW3-3	SW3-2	SW3-1										
Low-Cig Default:	OFF	OFF	OFF	895	915	915	915	915	See note 4				
Cooling Airflow (SW2) Low-Cooling Airflow (SW3)	OFF	OFF	ON	715	725	720	710	705	See note 4				
	OFF	ON	OFF	895	915	915	915	915	See note 4				
	OFF	ON	ON	1070	1090	1105	1115	1115	1110	1115	1120	1120	1110
	ON	OFF	OFF	1240	1265	1280	1295	1295	1305	1305	1305	1315	1315
	ON	OFF	ON	1520	1520	1515	1505	1495	1490	1480	1465	1455	1445
	ON	ON	OFF	1845	1840	1835	1835	1825	1820	1810	1800	1785	1775
	ON	ON	ON	2150	2145	2140	2145	2135	2130	2115	2100	2065	1985
Maximum Cig Airflow ²				2150	2145	2140	2145	2135	2130	2115	2100	2065	1985
CF Switches	SW3-3	SW3-2	SW3-1										
Cont. Fan Default:	OFF	OFF	OFF	895	915	915	915	915	See note 4				
Continuous Fan Airflow (SW3)	OFF	OFF	ON	715	725	720	710	705	See note 4				
	OFF	ON	OFF	805	820	815	810	810	See note 4				
	OFF	ON	ON	895	915	915	915	915	See note 4				
	ON	OFF	OFF	895	915	915	915	915	See note 4				
	ON	OFF	ON	895	915	915	915	915	See note 4				
	ON	ON	OFF	895	915	915	915	915	See note 4				
	ON	ON	ON	895	915	915	915	915	See note 4				
Heating (SW1)	High Heat Airflow ³			1825	1820	1815	1800	1800	1795	1785	1775	1760	1745
	Low Heat Airflow ³			1555	1555	1550	1550	1545	1525	1520	1505	1495	1485

1. Nominal 350 CFM/ton cooling airflow is delivered with SW1-5 and SW4-3 set to OFF.

Set SW1-5 to ON for nominal 400 CFM/ton (+15% airflow).

Set SW4-3 to ON for nominal 325 CFM/ton (-7% airflow).

Set both SW1-5 and SW4-3 to ON for nominal 370 CFM/ton (+7% airflow).

This applies to Cooling and Low-Cooling airflows, but does not affect continuous fan airflows.

The above adjustments in airflow are subject to motor horsepower range/capacity

2. Maximum cooling airflow is achieved when switches SW2-1, SW2-2, SW2-3 and SW1-5 are set to ON, and SW4-3 is set to OFF.

3. All heating CFM's are when comfort/efficiency adjustment switch (SW1-4) is set to OFF.

4. Ductwork must be sized for high-heating CFM within the operational range of ESP. Operation within the blank areas of the chart is not recommended because high-heat operation will be above 1.0 ESP.

5. All airflows on 21" (533 mm) casing size furnaces are 5% less on side return only installations.

*See Notes following table.

MAXIMUM ALLOWABLE EXPOSED VENT LENGTHS INSULATION TABLE

Table 1 – Maximum Allowable Exposed Vent Length in Unconditioned Space (Ft.)

Winter Design Temp °F	Unit Size	40,000* BTUH									60,000 BTUH											
		Uninsulated			3/8-in. Insulation			1/2-in. Insulation			Uninsulated			3/8-in. Insulation			1/2-in. Insulation					
	Pipe Dia. in.	1 ½	2	2 ½	1 ½	2	2 ½	1 ½	2	2 ½	1 ½	2	2 ½	3	1 ½	2	2 ½	3	1 ½	2	2 ½	3
20		20	20	20	20	50	45	20	60	50	20	30	30	25	20	75	65	60	20	85	75	65
0		10	5	5	20	25	20	20	30	25	15	15	10	10	20	40	30	25	20	45	40	30
-20		5			20	15	10	20	20	15	10	5			20	25	20	15	20	30	25	20
-40					15	10	5	15	15	10	5				20	15	15	10	20	20	15	10

Winter Design Temp °F	Unit Size	80,000 BTUH						100,000 BTUH								
		Uninsulated			3/8-in. Insulation			3/8-in. Insulation			1/2-in. Insulation					
	Pipe Dia. in.	1 ½	2	2 ½	3	4	1 ½	2	2 ½	3	4	1 ½	2	2 ½	3	4
20		15	40	40	35	30	15	50	90	75	65	15	50	70	70	70
0		15	20	15	10	5	15	50	45	35	30	15	50	50	40	35
-20		15	10	5			15	35	30	20	15	15	40	30	25	15
-40		10	5				15	25	20	15	5	15	30	25	20	10

Winter Design Temp °F	Unit Size	100,000 BTUH						120,000 BTUH						140,000 BTUH										
		Uninsulated			3/8-in. Insulation			3/8-in. Insulation			1/2-in. Insulation			Uninsulated			3/8-in. Insulation			1/2-in. Insulation				
	Pipe Dia. in.	2	2 ½	3	4	2	2 ½	2	2 ½	3	4	2	2 ½	3	4	2 ½	3	4	2 ½	3	4	2 ½	3	4
20		20	50	40	35	20	80	20	80	95	80	20	80	105	90	5	55	50	5	65	105	5	65	125
0		20	20	15	10	20	55	20	55	45	35	20	65	55	45	5	25	15	5	65	50	5	65	60
-20		15	10	5		20	35	20	35	30	20	20	45	35	25	5	10	5	5	45	30	5	50	40
-40		10	5			20	25	20	25	20	10	20	30	25	20	5	5		5	30	20	5	35	25

* Not all model families have these sizes

Maximum Allowable Exposed Vent Length in Unconditioned Space (Meters)

Winter Design Temp °C	Unit Size	40,000* BTUH									60,000 BTUH											
		Uninsulated			3/8-in. Insulation			1/2-in. Insulation			Uninsulated			3/8-in. Insulation			1/2-in. Insulation					
	Pipe Dia. mm	38	51	64	38	51	64	38	51	64	38	51	64	76	38	51	64	76	38	51	64	76
-7		6.1	6.1	6.1	6.1	15.2	13.7	6.1	18.3	15.2	6.1	9.1	9.1	7.6	6.1	22.9	19.8	18.3	6.1	25.9	22.9	19.8
-18		3.0	1.5	1.5	6.1	7.6	6.1	6.1	9.1	7.6	4.6	4.6	3.0	3.0	6.1	12.2	9.1	7.6	6.1	13.7	12.2	9.1
-29		1.5			6.1	4.6	3.0	6.1	6.1	4.6	3.0	1.5			6.1	7.6	6.1	4.6	6.1	9.1	7.6	6.1
-40					4.6	3.0	1.5	4.6	4.6	3.0	1.5				6.1	4.6	4.6	3.0	6.1	6.1	4.6	3.0

Winter Design Temp °C	Unit Size	80,000 BTUH						100,000 BTUH								
		Uninsulated			3/8-in. Insulation			3/8-in. Insulation			1/2-in. Insulation					
	Pipe Dia. mm	38	51	64	76	102	38	51	64	76	102	38	51	64	76	102
-7		4.6	12.2	12.2	10.7	9.1	4.6	15.2	27.4	22.9	19.8	4.6	15.2	21.3	21.3	21.3
-18		4.6	6.1	4.6	3.0	1.5	4.6	15.2	13.7	10.7	9.1	4.6	15.2	15.2	12.2	10.7
-29		4.6	3.0	1.5			4.6	10.7	9.1	6.1	4.6	4.6	12.2	9.1	7.6	4.6
-40		3.0	1.5				4.6	7.6	6.1	4.6	1.5	4.6	9.1	7.6	6.1	3.0

Winter Design Temp °C	Unit Size	100,000 BTUH						120,000 BTUH						140,000 BTUH								
		Uninsulated			3/8-in. Insulation			3/8-in. Insulation			1/2-in. Insulation			Uninsulated			3/8-in. Insulation			1/2-in. Insulation		
	Pipe Dia. mm	51	64	76	102	51	64	76	102	51	64	76	102	64	76	102	64	76	102	64	76	102
-7		6.1	15.2	12.2	10.7	6.1	24.4	28.9	24.4	6.1	24.4	32.0	27.4	1.5	16.7	15.2	1.5	19.8	32.0	1.5	19.8	38.1
-18		6.1	6.1	4.6	3.0	6.1	16.8	13.7	10.7	6.1	19.8	16.7	13.7	1.5	7.6	4.6	1.5	19.8	15.2	1.5	19.8	18.3
-29		4.6	3.0	1.5		6.1	10.7	9.1	6.1	6.1	13.7	10.7	7.6	1.5	3.0	1.5	1.5	13.7	9.1	1.5	15.2	12.2
-40		3.0	1.5			6.1	7.6	6.1	3.0	6.1	9.1	7.6	4.6	1.5	1.5		1.5	9.1	6.1	1.5	35	7.6

* Not all model families have these sizes

MAXIMUM EQUIVALENT VENT LENGTH - FT. (M)

NOTE: Maximum Equivalent Vent Length (MEVL) includes standard and concentric vent termination and does NOT include elbows. Use Table 3 - Deductions from Maximum Equivalent Vent Length to determine allowable vent length for each application.

Table 2 – Maximum Equivalent Vent Length - Ft.

Unit Size		60,000 ¹				80,000					100,000 ²				120,000		
Altitude (feet)	Pipe Dia. (in)	1 ½	2	2 ½	3	1 ½	2	2 ½	3	4	2	2 ½	3	4	2 ½	3	4
	0–2000	20	100	175	200	15	55	130	175	200	20	80	175	200	10	75	185
	2001–3000		95	165	185	10	49	125	165	185	15	75	165	185		5	70
	3001–4000	16	90	155	175			10	44	115			155	175	10		70
	4001–4500		85	150	170	10	41			110	150	165	10	65		150	
	4501–5000	15	80	145	165			10	38	90	145	160			10	60	140
	5001–6000		75	140	155	10	36				125	140	155	10			60
	6001–7000	13	70	130	145			10	33	80		125	140		10	55	
	7001–8000		65	120	135	10	30				75	120	125	10			50
	8001–9000	10	60	115	125			10	30	75		110	115		10	45	
9001–10000	N/A		55	105	115	10	30				75	100	105	10			45

Maximum Equivalent Vent Length – Meters																	
Unit Size		60,000 ¹				80,000					100,000 ²				120,000		
Altitude (meters)	Pipe Dia. (mm)	38	51	64	76	38	51	64	76	102	51	64	76	102	64	76	102
	0–610	6.0	30.4	53.3	60.9	4.5	16.7	39.6	53.3	60.9	6.0	24.3	53.3	60.9	3.0	22.8	56.3
	611–914	0.0	28.9	50.2	56.3	3.0	14.9	38.1	50.2	56.3	4.5	22.8	50.2	56.3	1.5	21.3	53.3
	915–1219	4.8	27.4	47.2	53.3		3.0	0.0	35.0	47.2			53.3	3.0		21.3	47.2
	1220–1370	4.5	25.9	45.7	51.8	3.0		13.4	33.5	44.1	48.7	3.0	19.8		45.7		50.2
	1371–1524		24.3	44.1	50.2		3.0	12.4	30.4	41.1	45.7			3.0	18.2	42.6	47.2
	1525–1829	3.9	22.8	42.6	47.2	3.0		11.5	27.4	38.1	42.6	3.0	16.7			41.1	44.1
	1830–2134		21.3	39.6	44.1		3.0	10.9	27.4	36.5	38.1			3.0	15.2	38.1	41.1
	2135–2438	3.0	19.8	36.5	41.1	3.0		10.0	24.3	33.5	35.0	3.0	13.7			35.0	38.1
	2439–2743		18.2	35.0	38.1		3.0	9.1	22.8	30.4	32.0			3.0	13.7	30.4	35.0
2744–3048	NA	16.7	32.0	35.0	3.0	9.1		22.8	30.4	32.0	3.0	13.7	30.4			35.0	NA

NOTES:

- Inducer Outlet Restrictor disk (P/N 337683–401; 1.25–in. (32 mm) Dia.) available through Replacement Components required for no greater than 5–ft. (1.5 M) TEVL in downflow and horizontal orientations only. Required for installations from 0–2000 ft. (0 to 610 M) above sea level.
- Inducer Outlet Restrictor disk (P/N 337683–402; 1.50–in. (38 mm) Dia.) available through Replacement Components required for no greater than 5–ft. (1.5 M) TEVL in downflow and horizontal orientations only. Required for installations from 0–2000 ft. (0 to 610 M) above sea level.

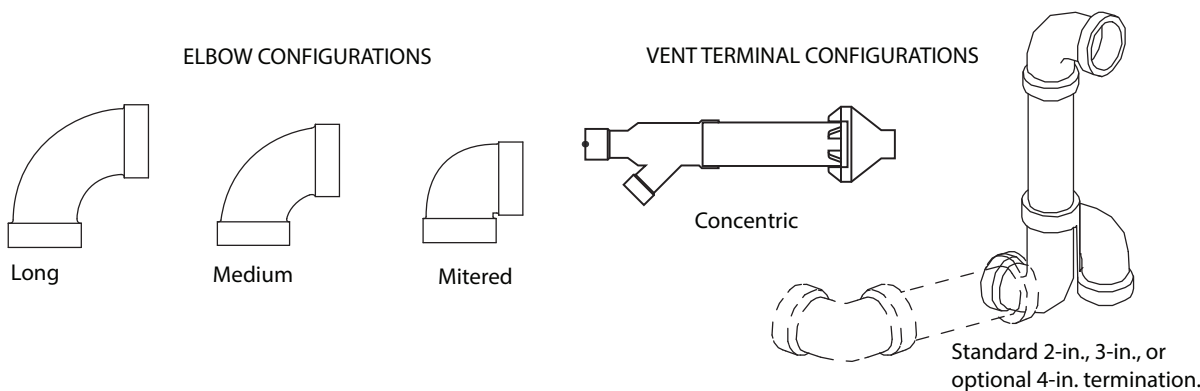

Table 3 – Deductions from Maximum Equivalent Vent Length - Ft. (M)

A13110

Pipe Diameter (in):	1-1/2		2		2-1/2		3		4	
Mitered 90° Elbow	8	(2.4)	8	(2.4)	8	(2.4)	8	(2.4)	8	(2.4)
Medium Radius 90° Elbow	5	(1.5)	5	(1.5)	5	(1.5)	5	(1.5)	5	(1.5)
Long Radius 90° Elbow	3	(0.9)	3	(0.9)	3	(0.9)	3	(0.9)	3	(0.9)
Mitered 45° Elbow	4	(1.2)	4	(1.2)	4	(1.2)	4	(1.2)	4	(1.2)
Medium Radius 45° Elbow	2.5	(0.8)	2.5	(0.8)	2.5	(0.8)	2.5	(0.8)	2.5	(0.8)
Long Radius 45° Elbow	1.5	(0.5)	1.5	(0.5)	1.5	(0.5)	1.5	(0.5)	1.5	(0.5)
Tee	16	(4.9)	16	(4.9)	16	(4.9)	16	(4.9)	16	(4.9)
Concentric Vent Termination	NA		0	(0.0)	NA		0	(0.0)	NA	
Standard Vent Termination	0	(0.0)	0	(0.0)	0	(0.0)	0	(0.0)	0	(0.0)

NOTES:

- Use only the smallest diameter pipe possible for venting. Over–sizing may cause flame disturbance or excessive vent terminal icing or freeze–up.
- NA – Not allowed. Pressure switch will not close, or flame disturbance may result.
- Vent sizing for Canadian installations over 4500 ft. (1370 M) above sea level are subject to acceptance by the local authorities having jurisdiction.
- Size both the combustion air and vent pipe independently, then use the larger size for both pipes.
- Assume the two 45° elbows equal one 90° elbow. Wide radius elbows are desirable and may be required in some cases.
- Elbow and pipe sections within the furnace casing and at the vent termination should not be included in vent length or elbow count.
- The minimum pipe length is 5 ft. (2 M) linear feet (meters) for all applications.
- Use 3–in. (76 mm) diameter vent termination kit for installations requiring 4–in. (102 mm) diameter pipe.

Venting System Length Calculations

The Total Equivalent Vent Length (TEVL) for **EACH** combustion air or vent pipe equals the length of the venting system, plus the equivalent length of elbows used in the venting system from Table 3.

Standard vent terminations or factory accessory concentric vent terminations count for zero deduction.

See vent system manufacturer's data for equivalent lengths of flexible vent pipe or other termination systems. **DO NOT ASSUME** that one foot of flexible vent pipe equals one foot of straight PVC/ABS DWV vent pipe.

Compare the Total Equivalent Vent Length to the Maximum Equivalent Vent Lengths in Table 2.

Example 1

A direct-vent 60,000 BTUH furnace installed at 2100 ft. (640M). Venting system includes **FOR EACH PIPE:**

70 feet (22 M) of vent pipe, 65 feet (20 M) of combustion air inlet pipe, (3) 90° long-radius elbows, (2) 45° long-radius elbows, and a factory accessory concentric vent kit.

Can this application use 2" (50 mm ND) PVC/ABS DWV vent piping?

Measure the required linear length of air inlet and vent pipe; insert the longest of the two here					70 ft. (22 M)	Use length of the longer of the vent or air inlet piping system
Add equiv length of (3) 90° long-radius elbows (use the highest number of elbows for either the vent or inlet pipe)	3	x	3 ft. (0.9 M)	=	9 ft. (2.7 M)	From Table 3
Add equiv length of (2) 45° long-radius elbows (use the highest number of elbows for either the vent or inlet pipe)	2	x	1.5 ft. (0.5 M)	=	3 ft. (0.9 M)	From Table 3
Add equiv length of factory concentric vent term					0 ft.	From Table 3
Add correction for flexible vent pipe, if any					0 ft.	From Vent Manufacturer's instructions; zero for PVC/ABS DWV
Total Equivalent Vent Length (TEVL)					82 ft. (25 M)	Add all of the above lines
Maximum Equivalent Vent Length (MEVL)					95 ft. (29 M)	For 2" pipe from Table 2
Is TEVL less than MEVL?					YES	Therefore, 2" pipe MAY be used

Example 2

A direct-vent 60,000 BTUH furnace installed at 2100 ft. (640M). Venting system includes **FOR EACH PIPE:**

100 feet (30 M) of vent pipe, 95 feet (29 M) of combustion air inlet pipe, (3) 90° long-radius elbows, and a polypropylene concentric vent kit. Also includes 20 feet (6.1 M) of flexible polypropylene vent pipe, included within the 100 feet (30 M) of vent pipe.

VERIFY FROM POLYPROPYLENE VENT MANUFACTURER'S INSTRUCTIONS for the multiplier correction for flexible vent pipe.

Can this application use 60mm o.d. (2") polypropylene vent piping? If not, what size piping can be used?

Measure the required linear length of RIGID air inlet and vent pipe; insert the longest of the two here: 100 ft. Of rigid pipe – 20 ft. Of flexible pipe				=	80 ft. (24 M)	Use length of the longer of the vent or air inlet piping system
Add equiv length of (3) 90° long-radius elbows (use the highest number of elbows for either the vent or inlet pipe)	3	x	5 ft. (1.5 M)	=	15 ft. (4.6 M)	Example from polypropylene vent manufacturer's instructions. Verify from vent manufacturer's instructions.
Add equiv length of 45° long-radius elbows (use the highest number of elbows for either the vent or inlet pipe)	0	x		=	0 ft. (0 M)	
Add equiv length of factory concentric vent term	9	x	3.3 ft. (0.9 M)	=	30 ft. (9 M)	
Add correction for flexible vent pipe, if any	2*	x	20 ft. (6.1 M)	=	40 ft. (12.2 M)	
* VERIFY FROM VENT MANUFACTURER'S INSTRUCTIONS; For example only, assume 1 meter of flexible 60mm (2") or 80mm (3") polypropylene pipe equals 2.0 meters (6.5 ft.) of PVC/ABS pipe.						
Total Equivalent Vent Length (TEVL)					165 ft. (50 M)	Add all of the above lines
Maximum Equivalent Vent Length (MEVL)					95 ft. (29 M)	For 2" pipe from Table 2
Is TEVL less than MEVL?					NO	Therefore, 60mm (2") pipe may NOT be used; try 80mm (3")
Maximum Equivalent Vent Length (MEVL)					185 ft. (57 M)	For 3" pipe from Table 2
Is TEVL less than MEVL?					YES	Therefore, 80mm (3") pipe MAY be used

RETURN AIR TEMPERATURE

This furnace is designed for continuous return-air minimum temperature of 60°F (15°C) db or intermittent operation down to 55°F (13°C) db such as when used with a night setback thermometer. Return-air temperature must not exceed 80°F (27°C) db. Failure to follow these return air limits may affect reliability of heat exchangers, motors and controls.

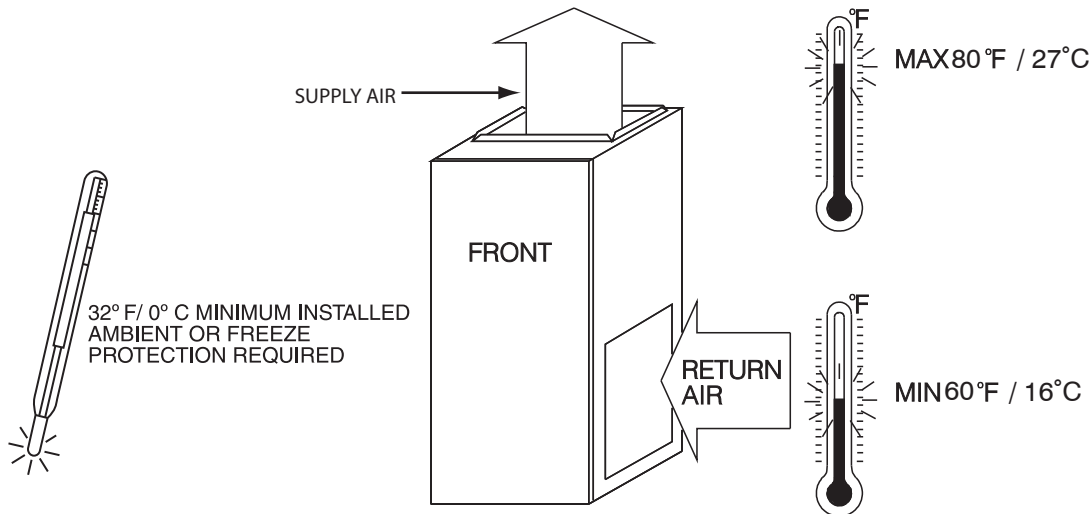

A10490

MINIMUM CLEARANCES TO COMBUSTIBLE MATERIALS

POSITION	CLEARANCE
Rear	0 (0 mm)
Front (Combustion air openings in furnace and in structure)	1 in. (25 mm)
Required for service**	24 in. (610 mm)*
All Sides of Supply Plenum**	1 in. (25 mm)
Sides	0 (0 mm)
Vent	0 (0 mm)
Top of Furnace	1 in. (25 mm)

* Recommended

** Consult your local building codes

COMBUSTION-AIR PIPE FOR NON-DIRECT (1-PIPE) VENT APPLICATION

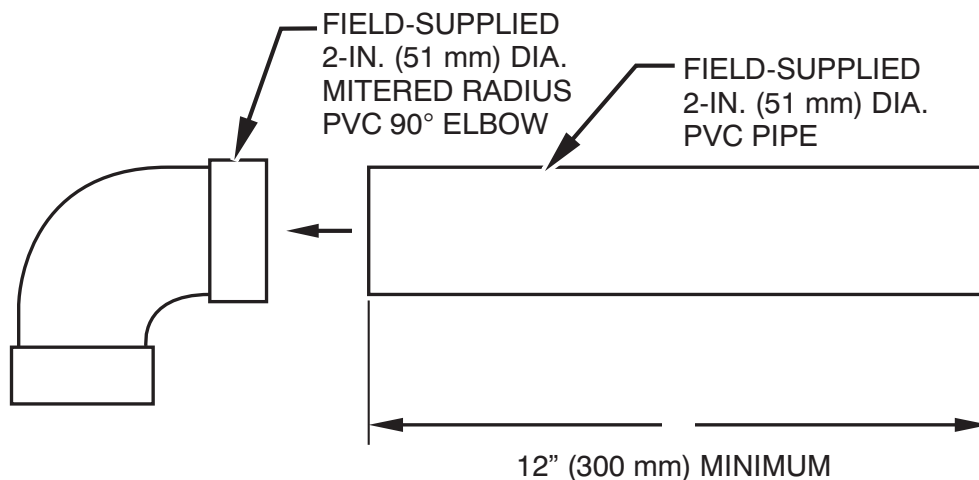

NOTE: See Installation Instructions for specific venting configurations.

A12376

DOWNFLOW SUBBASE

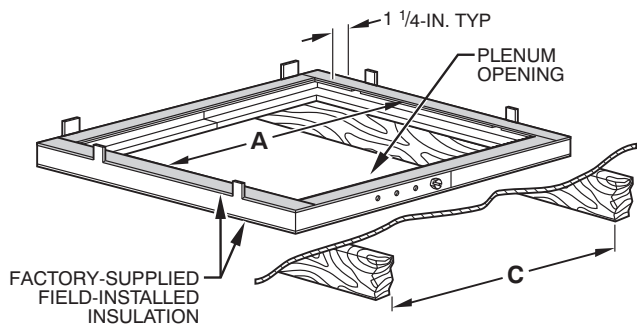

A97427

Assembled

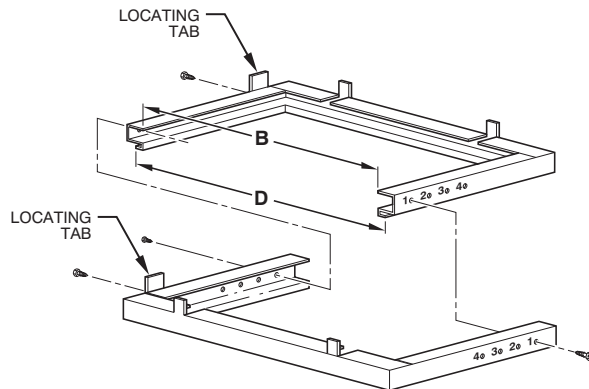

A88207

Disassembled

DIMENSIONS (IN. / MM)						
FURNACE CASING WIDTH	FURNACE IN DOWNFLOW APPLICATION	PLENUM OPENING*		FLOOR OPENING		HOLE NO. FOR WIDTH ADJUSTMENT
		A	B	C	D	
17-1/2 (444.5)	Furnace with or without Cased Coil Assembly or Coil Box	15-1/8 (384.2)	19 (482.6)	16-3/4 (425.5)	20-3/8 (517.5)	3
21 (533.4)	Furnace with or without Cased Coil Assembly or Coil Box	18-5/8 (396.4)	19 (482.6)	20-1/4 (514.4)	20-3/8 (517.5)	2
24-1/2 (622.3)	Furnace with or without Cased Coil Assembly or Coil Box	22-1/8 (562.0)	19 (482.6)	23-3/4 (603.3)	20-3/8 (517.5)	1

*The plenum should be constructed 1/4-in. (6 mm) smaller in width and depth than the plenum dimensions shown above.

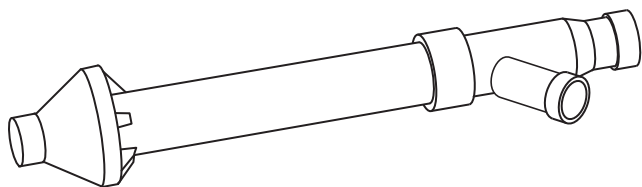

Concentric Vent Kit

A93086

A concentric vent kit allows vent and combustion-air pipes to terminate through a single exit in a roof or side wall. One pipe runs inside the other allowing venting through the inner pipe and combustion air to be drawn in through the outer pipe.

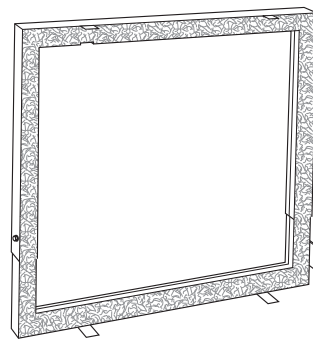

Downflow Subbase

A88202

One base fits all furnace sizes. The base is designed to be installed between the furnace and a combustible floor when no coil box is used or when a coil box other than a Bryant cased coil is used. It is CSA design certified for use with Bryant branded furnaces when installed in downflow applications.

MEDIA FILTER CABINET (OPTIONAL ACCESSORY)

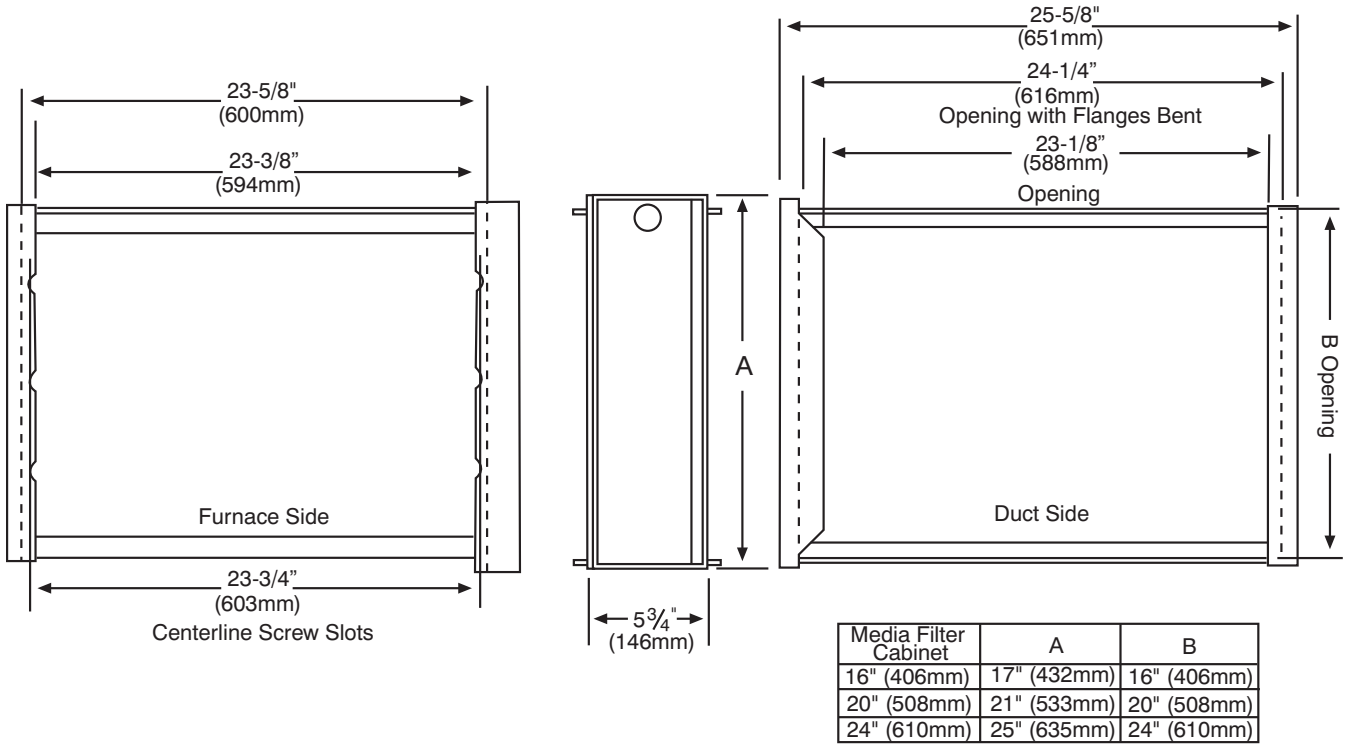

NOTE: Media cabinet is matched to the bottom opening on furnace. May also be used for side return.

A12428

TYPICAL WIRING SCHEMATIC

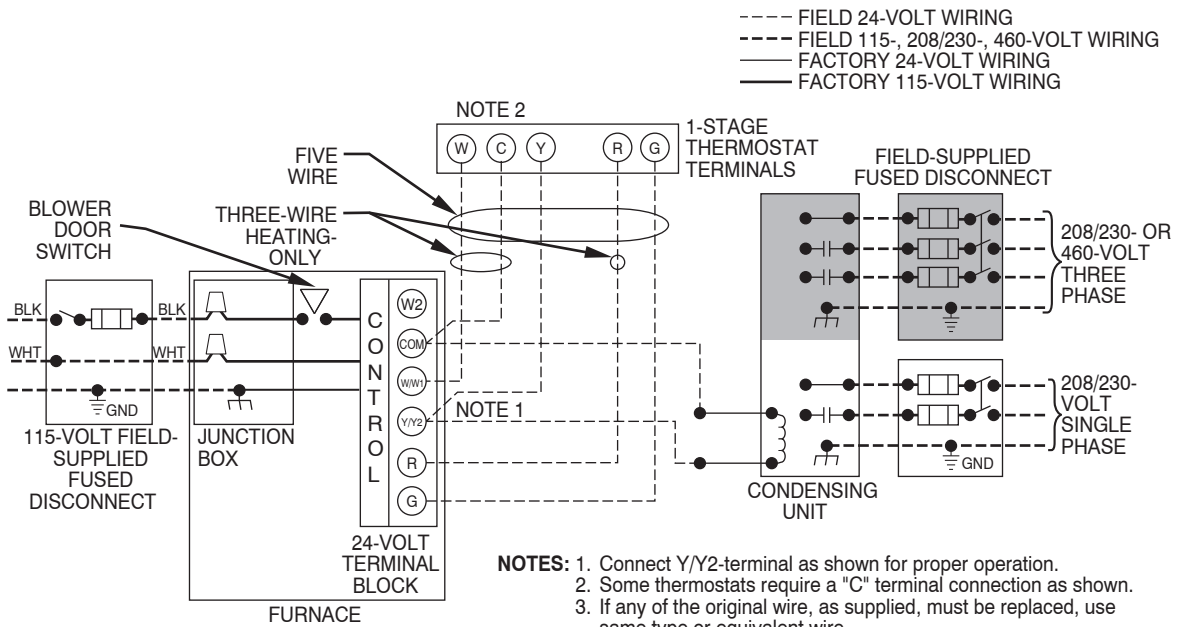

A11401

GUIDE SPECIFICATIONS

General

System Description

Furnish a _____ 4-way multipoise two-stage gas-fired condensing furnace for use with natural gas or propane (factory- authorized conversion kit required for propane); furnish external media cabinet for use with accessory media filter or standard filter.

Quality Assurance

Unit will be designed, tested and constructed to the current ANSI Z 21.47/CSA 2.3 design standard for gas-fired central furnaces.

Unit will be third party certified by CSA to the current ANSI Z 21.47/CSA 2.3 design standard for gas-fired central furnaces. Unit will carry the CSA Blue Star® and Blue Flame® labels. Unit efficiency testing will be performed per the current DOE test procedure as listed in the Federal Register.

Unit will be certified for capacity and efficiency and listed in the latest AHRI Consumer's Directory of Certified Efficiency Ratings.

Unit will carry the current Federal Trade Commission Energy Guide efficiency label.

Delivery, Storage, and Handling

Unit will be shipped as single package only and is stored and handled per unit manufacturer's recommendations.

Warranty (for inclusion by specifying engineer)

U.S. and Canada only. Warranty certificate available upon request.

Equipment

Blower Wheel and ECM Blower Motor

Galvanized blower wheel shall be centrifugal type, statically and dynamically balanced. Blower motor of ECM type shall be permanently lubricated with sealed ball bearings, of _____ hp, and have infinitely variable speed from 300-1300 RPM operating only when motor inputs are provided. Blower motor shall be direct drive and soft mounted to the blower housing to reduce vibration transmission.

Filters

Furnace shall have reusable-type filters. Filter shall be _____ in. (mm) X _____ in. (mm). An accessory highly efficient Media Filter is available as an option. _____ Media Filter.

Casing

Casing shall be of .030 in. thickness minimum, pre-painted steel.

Draft Inducer Motor

Draft Inducer motor shall be two-speed PSC design.

Primary Heat Exchangers

Primary heat exchangers shall be 3-Pass corrosion-resistant aluminized steel of fold-and-crimp sectional design and applied operating under negative pressure.

Secondary Heat Exchangers

Secondary heat exchangers shall be of a stainless steel flow-through of fin-and-tube design and applied operating under negative pressure.

Controls

Controls shall include a micro-processor-based integrated electronic control board with at least 16 service troubleshooting codes displayed via diagnostic flashing LED light on the control, a self-test feature that checks all major functions of the furnace, and a replaceable automotive-type circuit protection fuse. Multiple operational settings available, including separate blower speeds for low heat, high heat, low cooling, high cooling and continuous fan. Continuous fan speed may be adjusted from the thermostat. Cooling airflow will be selectable between 325 to 400 CFM per ton of air conditioning. Features will also include temporary reduced airflow in the cooling mode for improved dehumidification when an Evolution Control or TP-PRH edge® is selected as the thermostat.

Operating Characteristics

Heating capacity shall be _____ Btuh input; _____ Btuh output capacity.

Fuel Gas Efficiency shall be _____ AFUE.

Air delivery shall be _____ cfm minimum at 0.50 in. W.C. external static pressure.

Dimensions shall be: depth _____ in. (mm); width _____ in. (mm); height _____ in. (mm) (casing only).

Height shall be _____ in. (mm) with A/C coil and _____ in. (mm) overall with plenum.

Electrical Requirements

Electrical supply shall be 115 volts, 60 Hz, single-phase (nominal). Minimum wire size shall be _____ AWG; maximum fuse size of HACR-type designated circuit breaker shall be _____ amps.

Special Features

Refer to section of the product data identifying accessories and descriptions for specific features and available enhancements.

