

CE

# iServer MicroServer™



# User's Guide

Shop on line at  
**omega.com**

Ω OMEGA

omega.com

e-mail: [info@omega.com](mailto:info@omega.com)

For Latest Product Manuals  
[omegamanual.info](http://omegamanual.info)

# iTHX-SD

## Temperature + Humidity



**OMEGAnet® Online Service**  
**omega.com**

**Internet e-mail**  
**info@omega.com**

### **Servicing North America:**

**U.S.A.:**  
ISO 9001 Certified

Omega Engineering, Inc., One Omega Drive, P.O. Box 4047  
Stamford, CT 06907-0047 USA

Toll Free: 1-800-826-6342  
FAX: (203) 359-7700

TEL: (203) 359-1660  
e-mail: info@omega.com

**Canada:**

976 Berar  
Laval (Quebec), H7L 5A1, Canada  
Toll-Free: 1-800-826-6342  
FAX: (514) 856-6886

TEL: (514) 856-6928  
e-mail: info@omega.ca

### **For immediate technical or application assistance:**

**U.S.A. and Canada:** Sales Service: 1-800-826-6342/1-800-TC-OMEGA®

Customer Service: 1-800-622-2378/1-800-622-BEST®

Engineering Service: 1-800-872-9436/1-800-USA-WHEN®

**Mexico/  
Latin America:**

TEL: 001 (203) 359-1660  
e-mail: espanol@omega.com

FAX: 001 (203) 359-7700

### **Servicing Asia:**

**China:**

1698 Yi Shan Road, Unit 102  
Min Hang District  
Shanghai, China 201103 P.R.C.  
Hotline: 800 819 0559/400 619 0559  
e-mail: info@cn.omega.com

### **Servicing Europe:**

**Benelux:**

Toll-Free: 0800 099 3344  
FAX: +31 20 643 46 43

TEL: +31 20 347 21 21  
e-mail: sales@omegaeng.nl

**Czech Republic:**

Frystatska 184  
733 01 Karviná, Czech Republic  
TEL: +420-59-6311899  
e-mail: info@omegashop.cz

FAX: +420-59-6311114

**France:**

Toll-Free: 0805 541 038  
FAX: 01 57 32 48 18

TEL: 01 57 32 48 17  
e-mail: esales@omega.fr

**Germany/ Austria:**

Daimlerstrasse 26  
D-75392 Deckenpfronn, Germany  
Toll-Free: 0800 8266342  
FAX: +49 (0) 7056 9398-29

TEL: +49 (0) 7056 9398-0  
e-mail: info@omega.de

**United Kingdom:**  
ISO 9001 Certified

OMEGA Engineering Ltd.  
One Omega Drive, River Bend Technology Centre, Northbank  
Irlam, Manchester M44 5BD United Kingdom  
Toll-Free: 0800-488-488  
FAX: +44 (0) 161 777-6622

TEL: +44 (0) 161 777-6611  
e-mail: sales@omega.co.uk

---

It is the policy of OMEGA Engineering, Inc. to comply with all worldwide safety and EMC/EMI regulations that apply. OMEGA is constantly pursuing certification of its products to the European New Approach Directives. OMEGA will add the CE mark to every appropriate device upon certification.

The information contained in this document is believed to be correct, but OMEGA accepts no liability for any errors it contains, and reserves the right to alter specifications without notice.

**WARNING:** These products are not designed for use in, and should not be used for, human applications.

# TABLE OF CONTENTS

<b>Part 1: INTRODUCTION</b>	
1.1 Safety and EMC Considerations .....	2
1.2 Before You Begin .....	2
1.3 Description .....	2
<b>Part 2: HARDWARE</b>	
2.1 Dimensions .....	5
2.2 Wall Mounting .....	6
2.3 Parts of the iServer Unit.....	7
2.4 Disassembly Instruction .....	8
2.5 Network Communication Interfaces .....	9
2.5.1 10/100 BASE-T RJ-45 Pinout.....	9
2.5.2 Connecting iServer to PC/Hub/Switch/Router.....	9
2.6 Relay Wiring Connections .....	9
<b>PART 3 NETWORK CONFIGURATION</b>	
3.1 Network Protocols .....	10
3.2 Ethernet (MAC) Address .....	10
3.3 DHCP .....	11
3.4 DNS .....	11
3.5 IP Address .....	11
3.6 Port Number .....	12
<b>PART 4 OPERATIONS</b> .....	
4.1 IP Address Assignment .....	12
4.1.1 DHCP (Method 1).....	12
4.1.2 ARP HTTPget Commands (Method 2) .....	13
4.1.3 Direct Connection (Method 3).....	13
4.1.4 iConnect Software (Method 4) .....	17
4.2 Access and Configuration Using a Web Browser .....	19
4.3 LOGIN and ADMINISTRATOR Passwords.....	19
4.4 Setup .....	20
4.4.1 Overview .....	20
4.4.2 Network.....	21
4.4.2.1 IP Configuration.....	21
4.4.2.2 Ethernet Port.....	23
4.4.3 Configuration.....	23
4.4.3.1 Data and Time .....	23
4.4.3.2 Server .....	25
4.4.3.3 Sensors .....	25
4.4.3.4 Alarm Relays.....	27
4.4.4 Management .....	29
4.4.4.1 Setup .....	29
SNMP Simple Network Management Protocol.....	29
SMTP Simple Mail Transfer Protocol.....	30
4.4.4.1.1 Sending Text Messages to a Cell Phone.....	30
4.4.4.2 Alarms .....	30

## TABLE OF CONTENTS (continued)

4.4.5 Security .....	32
4.4.6 Recording .....	34
4.4.6.1 Start Recording.....	34
4.4.6.2 Status.....	36
4.4.6.3 Data Retrieval.....	37
4.4.6.4 Format SD Card .....	38
4.4.7 System .....	38
4.4.7.1 Reboot .....	38
4.4.7.2 Defaults .....	39
4.4.7.3 Upgrade .....	39
4.4.7.4 Download Configuration.....	40
4.4.7.5 Upload Configuration .....	41
4.4.8 Diagnostics.....	41
4.4.9 Log Out .....	41
4.5 Readings .....	42
4.5.1 HTML .....	42
4.5.2 Java .....	43
4.6 Chart .....	44
4.7 Web Link.....	45
4.8 Telnet Setup .....	46
4.8.1 Telnet Connection.....	46
4.9 HTTPget Program.....	47
4.9.1 HTTPget using Port 2000.....	48
4.10 Flash Card Reader.....	50
4.11 iLog Software.....	52
PART 5 SPECIFICATIONS.....	54
APPENDIX A GLOSSARY .....	56
APPENDIX B IP Address.....	57
APPENDIX C ARP Commands .....	58
APPENDIX D IP Netmask .....	59
APPENDIX E ASCII Chart.....	60
APPENDIX E ASCII Control Codes .....	61
APPENDIX F iLog Error Messages .....	62
APPENDIX G Java Runtime Environment Setup.....	63
APPENDIX H Sensor Information.....	65
APPENDIX J SNMP .....	67
Part 6: APPROVALS INFORMATION	
6.1 CE APPROVALS .....	68

## LIST OF FIGURES:

Figure 1.1	iServer and iLD Big Display on the Ethernet Network.....	4
Figure 2.1	Dimensions .....	5
Figure 2.2	Wall Mounting.....	6
Figure 2.3	Parts of the iServer Unit.....	7
Figure 2.4	Opening the Unit.....	8
Figure 2.5	RJ45 Pinout.....	9
Figure 2.6	Relay Connections .....	9
Figure 3.1	Labeling .....	10
Figure 4.1	ARP and HTTPget Commands on a DOS Window .....	13
Figure 4.2	Connecting Computer Directly to iServer .....	14
Figure 4.3	Network Connections.....	14
Figure 4.4	Local Area Connection .....	14
Figure 4.5	Changing TCP/IP Properties on Your Computer .....	15
Figure 4.6	iServer Welcome Page.....	16
Figure 4.7	Pinging the iServer from MS-DOS Prompt.....	16
Figure 4.8	Assigning an IP Address using iConnect .....	17
Figure 4.9	Accessing the iServer's using iConnect .....	18
Figure 4.10	iServer Welcome Page.....	19
Figure 4.11	LOGIN and ADMINISTRATOR Passwords.....	19
Figure 4.12	Overview .....	20
Figure 4.13	Network: IP Configuration .....	21
Figure 4.14	Network: Ethernet Configuration .....	23
Figure 4.15	Network: Ethernet Configuration .....	24
Figure 4.16	Configuration Menu: Server .....	25
Figure 4.17	Configuration Menu: Sensors .....	26
Figure 4.18	Configuration Menu: Alarm Relays.....	28
Figure 4.19	Management Menu: Setup.....	29
Figure 4.20	Management Menu: Alarms.....	30
Figure 4.21	Security Menu .....	32
Figure 4.22	Recording Menu: Start Recording .....	34
Figure 4.23	Recording Menu: Status .....	36
Figure 4.24	Recording Menu: Data Retrieval .....	37
Figure 4.25	Recording Menu: Format SD Card.....	38
Figure 4.26	System: Reboot .....	38
Figure 4.27	System: Defaults .....	39
Figure 4.28	System: Upgrade .....	39
Figure 4.29	System: Download Configuration.....	40
Figure 4.30	System: Upload Configuration.....	40
Figure 4.31	Diagnostics .....	41
Figure 4.32	Readings: HTML .....	42
Figure 4.33	Readings: Java .....	43
Figure 4.34	Adjustable Chart.....	44
Figure 4.35	Web Link .....	45
Figure 4.36	Tera Term Telnet Connection Screen.....	46
Figure 4.37	Telnet to port 2002 – p command .....	47
Figure 4.38	Telnet to port 2002 – ? command .....	47
Figure 4.39	Recorded Data File Directory .....	53
Figure 4.40	Example of data recorded on the SD card, standard text (.txt) file format	53

## **LIST OF FIGURES (continued)**

Figure 4.41 iLog Software Logging Data.....	54
Figure C.1 ARP Commands and Responses .....	58
Figure G.1 Java 1.7 Screen Shot.....	63
Figure H.1 RH Accuracy Chart .....	65
Figure H.2 Temperature Accuracy Chart.....	65
Figure H.3 Normal Range.....	65

## **LIST OF TABLES**

Table 2.1 Parts of iServer Unit.....	7
Table 4.1 iLog Excel Applications.....	53
Table F-1 iLog Error Messages .....	62
Table J-1 SNMP MIB-2 .....	67
Table J-2 SNMP Trap .....	67

## NOTES, WARNINGS and CAUTIONS

Information that is especially important to note is identified by the following labels:

- **NOTE**
- **WARNING or CAUTION**
- **IMPORTANT**
- **TIP**

**Note**

**NOTE:** Provides you with information that is important to successfully setup and use the iServer.



**CAUTION:** Tells you about the risk of electrical shock.



**CAUTION:** Risk of danger. Tells you of circumstances or practices that can affect the instrument's functionality and must refer to accompanying documents.

**Tip**

**TIP:** Provides you helpful hints.

---

## FEATURES

- **Temperature**
- **Relative Humidity**
- **Web Server**
- **Dual Probe Capability**
- **Virtual Chart Recorder**
- **Two Relay Alarms**
- **2GB SD Flash Memory Card**
- **Password Protection**
- **Email Alarms**
- **Data Logging**
- **Real Time Clock**
- **Accurate Readings**
- **SNMP Trap**
- **LCD Display**
- **Back-up Battery 9Vdc**

## **PART 1**

### **INTRODUCTION**

#### **1.1 Safety and EMC Considerations**

Refer to the CE Approvals Section.

##### **EMC Considerations**

- Whenever EMC is an issue, always use shielded cables.
- Never run signal and power wires in the same conduit.
- Use twisted-pair wires for signal connections.
- Install Ferrite Bead(s) on signal wires close to the instrument if EMC problems persist.

**Failure to follow all instructions and warnings may result in injury!**

#### **1.2 Before You Begin**

**Inspecting Your Shipment:** Remove the packing slip and verify that you have received everything listed. Inspect the container and equipment for signs of damage as soon as you receive the shipment. Note any evidence of rough handling in transit. Immediately report any damage to the shipping agent. The carrier will not honor damage claims unless all shipping material is saved for inspection. After examining and removing the contents, save the packing material and carton in the event reshipment is necessary.

**Customer Service:** If you need assistance, please contact the Customer Service Department nearest you.

**Manuals, Software:** The latest Operation Manual as well as free configuration software (**iConnect**) and datalogging software (**iLog**) are available at **the website listed on the cover page of this manual** or on the CD-ROM enclosed with your shipment.

#### **1.3 Description**

**View Temperature + Humidity with a Web Browser.** The iServer let's you monitor and record Temperature, Relative Humidity and Dew Point over an Ethernet network or the Internet with no special software -- just a Web browser. The iServer serves Active Web Pages to display real time readings and display charts of temperature, humidity and dew point, or log data in standard data formats for use in a spreadsheet or data acquisition program such as Excel or Visual Basic.

**Adjustable Charts.** The Java™ Applet chart scales are fully adjustable on the fly. For example, the chart can display one day, one week, one month or one year. Temperature and humidity can be charted across the full span (-40 to 124°C, and 0 to 100% RH) or within any narrow range (such as 20 to 30°C).

When a second sensor is added, users can select a chart that records channel 1, channel 2 or the difference of the two channels.

**SD Flash Memory Card.** The iServer comes complete with a removable 2 GB SD Flash Memory card that can store up to seven years of readings taken at ten second intervals. The data is recorded on widely available SD (Secure Digital) flash cards. The format is a simple text file that is easily imported to spreadsheets and other programs. It can be read on a PC or MAC with a USB card reader. You can also download the data remotely over an Ethernet network or the Internet.

Installation and operation of the iServer requires no special training, tools, or software. The device connects to any Ethernet network with standard cable and is powered by a universal 100 to 240 Vac adapter which is supplied with the product.

### 1.3 Description (continued)

**Back-up Battery.** The iServer comes with a universal 100 to 240 Vac power adapter. A standard 9 Volt Alkaline battery (also included) allows the device to continue recording data for 60 hours (at one minute interval setting) without external ac power (such as a power outage).

**Display and Chart Two Channels.** The transmitter comes complete with a temperature and humidity probe for measurement of a single location.

With the addition of a second probe, the transmitter can measure and display temperature, humidity and dew point in a second location up to ten feet away.

The transmitter can display and chart absolute measurements in both locations, or a differential measurement between the two locations. The second probe requires no change to the basic transmitter hardware, it can be added at the time of purchase or in the future. A choice of industrial probes in 2" and 5" lengths, and a wand style for ambient indoor applications are available. A simple DB-9 "Y" connector is required for adding a second probe.

**Sensor and Calibration.** It is not necessary to take the iTHX-SD out of service for routine calibration. The temperature/humidity sensors are interchangeable and can be replaced for about the same cost as a typical calibration. Replacement sensors with optional 3-point NIST traceable calibration certificates are available.

**Email Alarms.** The device can trigger an alarm if temperature or humidity goes above or below a set point that you determine. Your alarm can be sent by email to a single user or to a group distribution list, including text messages to cell phones and PDA's.

**Alarm Relays.** The iServer features two 1.5 Amp relays. With the easy Web-based setup page, the two relays can be programmed for any combination of temperature or humidity, and high or low set points. The relays can also be programmed to remain latched and require a manual reset if a limit is exceeded.

**Link to Web CAM or IP Camera.** The Web page includes a link to a "Web Cam" or "IP camera" (not included). If you get a message about an alarm condition, you can quickly click on the link to view the actual scene over the Internet.

### 1.3 Description (continued)

**Award-winning Technology.** The iServer is simple to install and use. It features award winning technology that requires no special software except a Web browser. The iServer connects to an Ethernet Network with a standard RJ45 connector and sends data in standard TCP/IP packets. It is easily configured with a simple menu using a Web browser and can be password protected. From within an Ethernet LAN or over the Internet, the user simply types its IP address or an easy-to-remember name such as “Cleanroom5” or “ServerRoom” in any Web Browser, and the iServer serves a Web Page with the current readings. The iServer comes complete with one temperature/humidity wand probe, universal ac power adapter, 9V battery, SD card, and full documentation.

#### Example:

A standard web browser can be used to monitor and chart temperature and humidity. The browser can also be used to configure the device’s IP address, passwords for access and all configuration parameters. An iLD Big Display can display temperature and humidity received from an iServer over the Ethernet or the Internet.

The following example illustrates how you can hookup an iServer and iLD to your network:

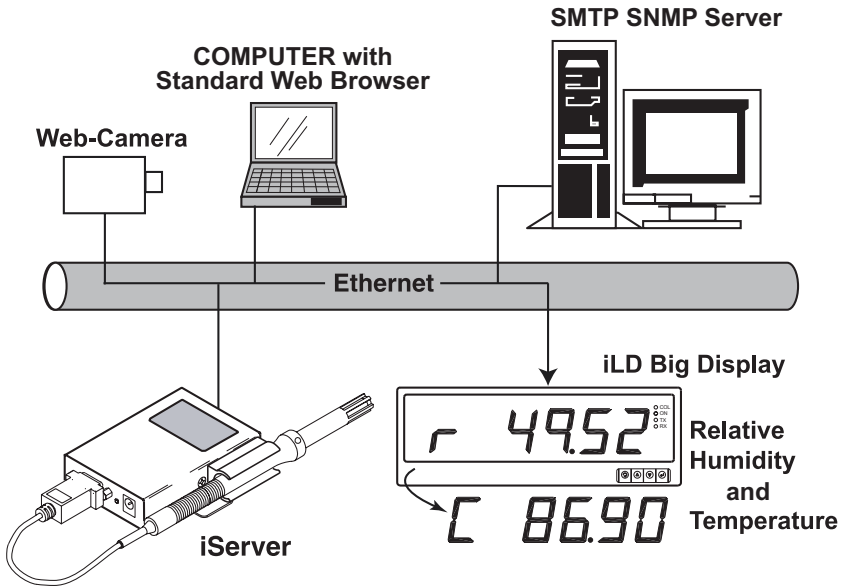

Figure 1.1 iServer and iLD Big Display on the Ethernet Network

## PART 2 HARDWARE

### 2.1 Dimensions

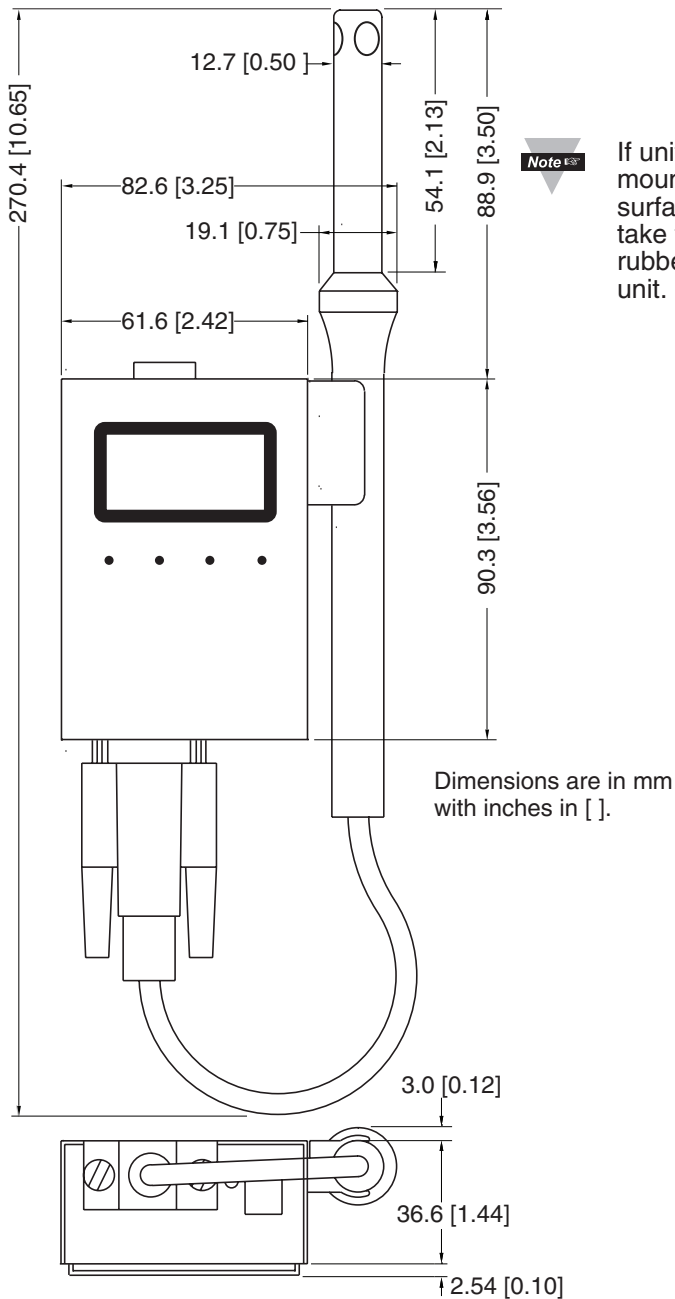
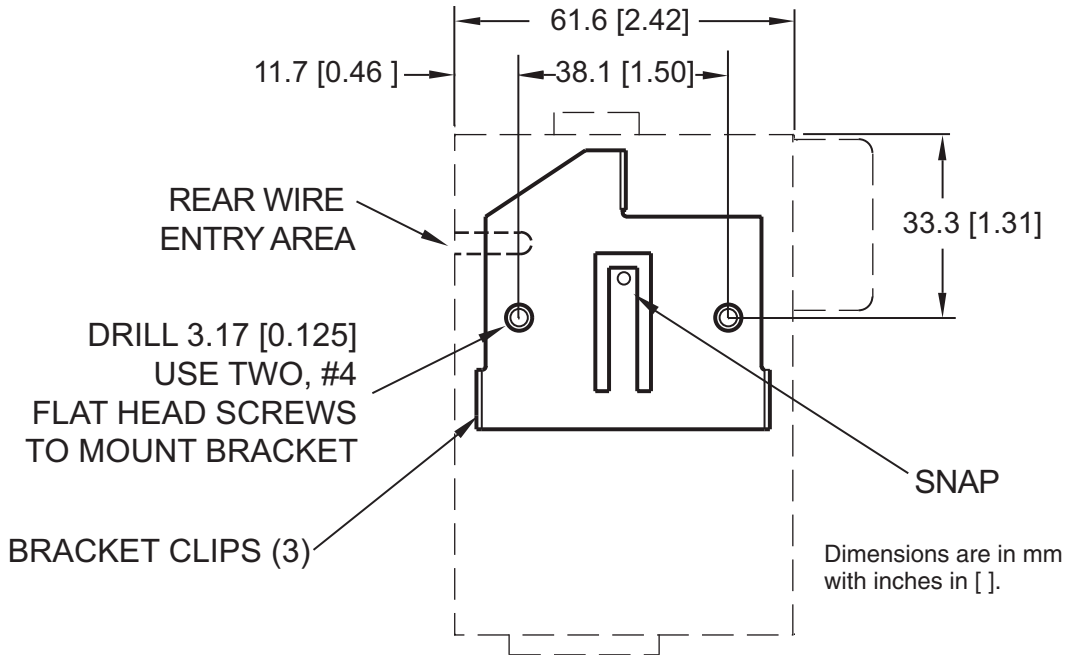

Figure 2.1 Dimensions

## 2.2 Wall Mounting

Position unit where required. Mark and drill the two #4 screw holes.

After bracket is mounted on the wall, align back of unit over the three bracket clips, once engaged, slide downward, the unit will snap in place.

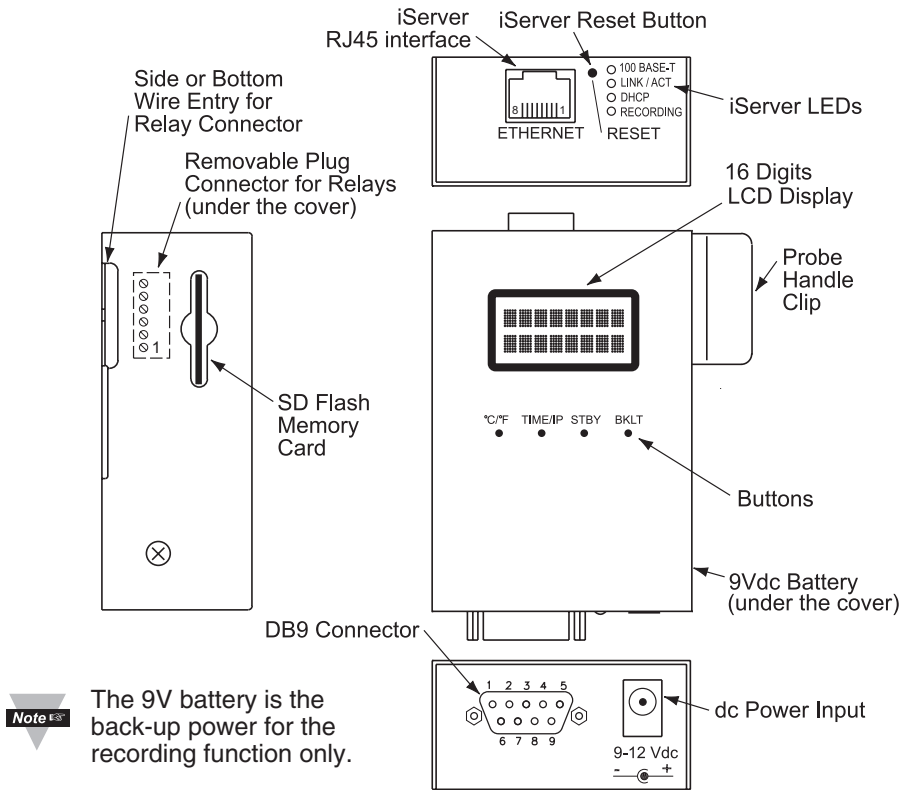

**Figure 2.2 Wall Mounting**



It is recommended that you ground your unit by connecting a wire to the Return/Ground position of the relay connector, see **Figure 2.6**.

## 2.3 Parts of the iServer Unit



**Figure 2.3 Parts of the iServer Unit**

**Table 2.1 Parts of iServer Unit**

<b>ETHERNET</b>	RJ45 interface for 10/100BASE-T connection.
<b>RESET</b>	Button: Momentary (Push and Release) resets power on unit; Push and Hold for 10 seconds to reset unit to factory defaults and reset power.
<b>100 BASE-T</b>	LED (Green) On: Indicates 100 Mbps; LED Off: Indicates 10 Mbps.
<b>LINK/ACT</b>	LED (Green) On/Blinking: Indicates good network link and network activities (receiving or sending packets).
<b>DHCP</b>	LED (Yellow): When DHCP is enabled, once the iServer receives the IP parameters from the DHCP server this LED will turn Solid yellow.
<b>RECORDING</b>	LED (Green) Blinking <i>Fast</i> : Indicates that the unit is recording. LED Blinking: during back-up battery operation according to sampling rate, or recording interval if recording is ON.
<b>°C/°F</b>	Button: Press to change LCD display units of measurement between °C and °F. Press and Hold along with <b>TIME/IP</b> button during power-on, this will enable DHCP mode.
<b>TIME/IP</b>	Button: Press repeatedly to change LCD display from: 1) Date and Time; 2) Temperature and Humidity; 3) iServer's IP address. Press and Hold along with <b>°C/°F</b> button during power up, this will enable DHCP mode.

## 2.3 Parts of the iServer Unit (continued)

<b>STBY</b>	Button: 1) Stops the recording 2) Press before ejecting Flash Card. NOTE: display will show "Safe to Eject SD" after button has been pressed.
<b>BKLT</b>	Button: Push and Hold to display Backlight on LCD when it is running on the back-up battery (backlight is always on while running on the ac adapter).

## 2.4 Disassembly Instruction

You may need to open the unit for one of the following reasons:

- To wire relay connector. (Refer to **Figure 2.6**)
- To connect or replace the battery.

**!** Disconnect the power supply before proceeding.

- Make sure the flash memory card is fully inserted (or removed), before removing the cover.
- Remove probe from handle clip (if needed).

Remove cover, by removing 2 mounting screws on each side.

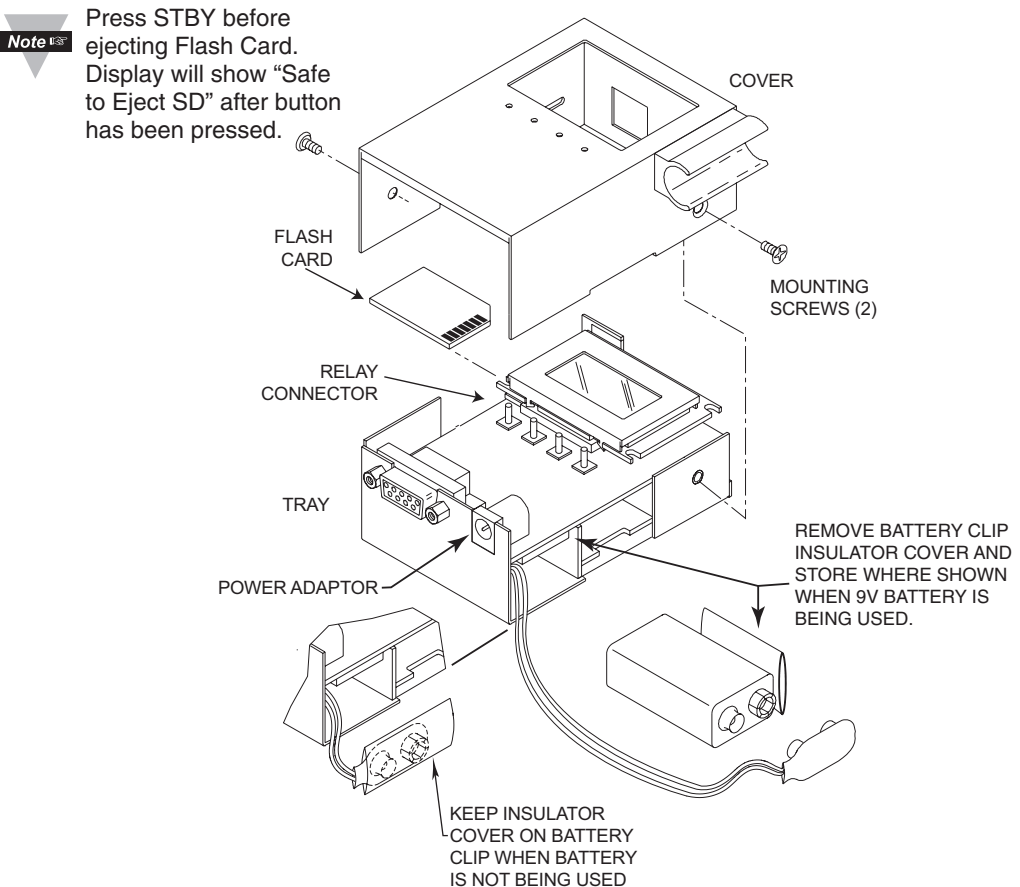

**Figure 2.4 Opening the Unit**

## 2.5 Network Communication Interfaces

### 2.5.1 10/100 BASE-T RJ-45 Pinout

The 10/100BASE-T Ethernet network system is used in the iServer for network connectivity. The 10 Mbps or 100 Mbps twisted-pair Ethernet system operates over two pairs of wires. One pair is used for receiving data signals and the other pair is used for transmitting data signals. This means that four pins of the eight-pin connector are used.

### ETHERNET

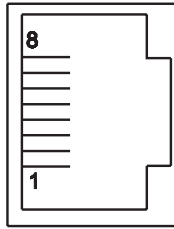

Pin	Name	Description
1	+Tx	+Transmit Data
2	- Tx	-Transmit Data
3	+RX	+Receive Data
4	N/C	Not Connected
5	N/C	Not Connected
6	-Rx	-Receive Data
7	N/C	Not Connected
8	N/C	Not Connected

Figure 2.5 RJ45 Pinout

**Note** For CE compliance at 100 Mbps: use shielded cable, opposite end of cable must be grounded.

### 2.5.2 Connecting iServer to PC/Hub/Switch/Router

The iServer’s Ethernet interface can automatically detect the Rx and Tx lines on a twisted pair Ethernet cable (MDI/MDIX Auto Cross). Therefore, to connect an iServer to a PC/Hub/Switch/Router, either a straight-through or a cross-over cable can be used.

**Note** On certain devices (like iServer), it is possible for the hardware to automatically correct errors in cable selection, making the distinction between a “straight-through” cable and a “cross-over” cable unimportant. This capability is known as “Auto MDI/MDIX”.

## 2.6 Relay Wiring Connections

**Note** To access the Relay Connector you must remove the cover, refer to **Section 2.4**. It is recommended that you ground your unit by connecting a wire to the Ground/Return position of the relay connector.

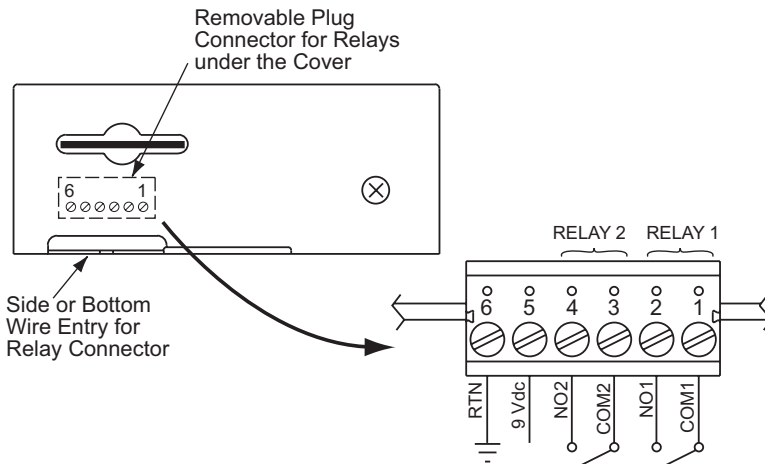

Figure 2.6 Relay Connections

## PART 3

### NETWORK CONFIGURATION

#### 3.1 Network Protocols

The iServer can be connected to an Ethernet network communicating through standard IP protocols including TCP, UDP, SNMP, SMTP, ARP, HTTP (WEB access), DNS, DHCP, ICMP, SNTP, and Telnet.

#### 3.2 Ethernet (MAC) Address

MAC (Media Access Control) address is a unique hardware number for Ethernet devices like computers, network switches, print servers, etc. When you're connected to an Ethernet LAN using a computer you can see a table of IP addresses called "ARP table" stored on that computer. The ARP table relates IP addresses of devices on a network to their corresponding MAC addresses. The MAC address can be found on a label attached to your Ethernet device and it contains 6 bytes (12 characters) of hexadecimal numbers XX:XX:XX:XX:XX:XX hex

For example: 0A:0C:3D:0B:0A:0B



Remove the small label with the default IP address of 192.168.1.200 and there will be room to put your IP address. See **Figure 3.1**

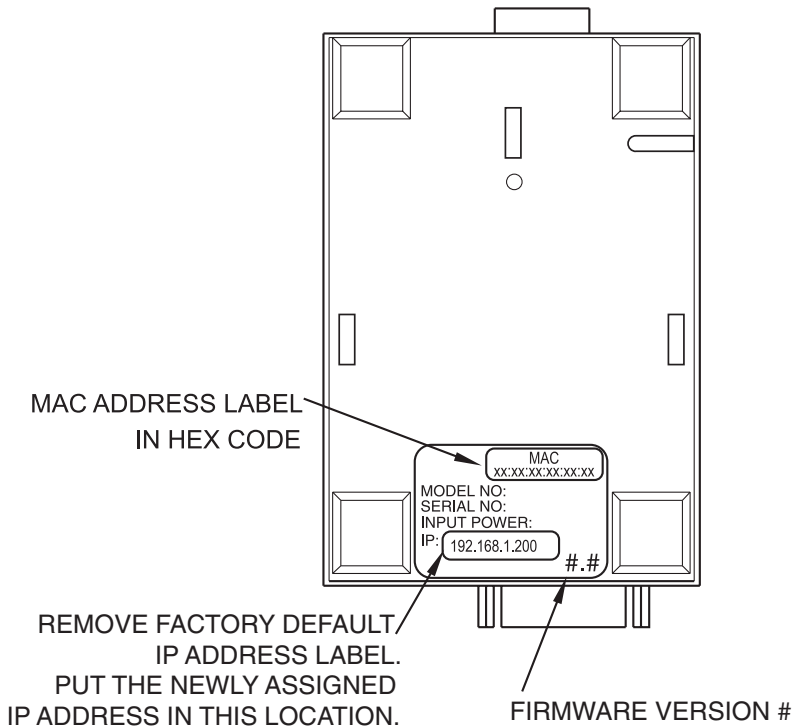

**Figure 3.1 Labeling**

### 3.3 DHCP

DHCP, Dynamic Host Configuration Protocol, enables computers and network devices to receive their IP configurations from a DHCP server.

If DHCP is enabled on your iServer, as soon as the iServer that is connected to the network is powered on, there will be an exchange of information between the iServer and the DHCP server. As a result, the DHCP server will assign an IP address, a Gateway address, a Subnet Mask, and a DNS address to the iServer. Note that the DHCP server must be correctly configured to make such assignments.

If fixed or static IP address is desired, the DHCP function must be disabled.

The iServer is shipped with DHCP disabled (factory default).

The DHCP can be enabled by accessing the iServer's web server and selecting Network menu (refer to **Section 4.4.2**) **or** by pressing and holding the two front buttons °C/°F and **TIME/IP** during power-on (refer to **Section 2.3**).

**Note** 

It's very important to communicate with the network administrator in order to understand DHCP and its existing configurations on the host server before enabling DHCP on the iServer.

**Note** 

The iServer is shipped with a default static IP address of **192.168.1.200** and Subnet Mask of **255.255.255.0**.

### 3.4 DNS

DNS, Domain Name System, enables computers and devices to be recognized over a network based on a specific name instead of IP addresses.

For example, instead of having to use **http://192.168.1.200** (IP address), you would use **http://ithx03ec** or any name up to sixteen alphanumeric characters defined as a Host Name in the iServer's web server.

The default Host Name for an iServer is "ithx" followed by the **last four digits** of the MAC address of that iServer unit.

**Note** 

On Windows servers where DHCP and DNS are separate functions it is very important to configure the DHCP server to communicate with DNS in order for the iServer's Host Name to correctly respond. If you cannot access the iServer using its Host Name, please contact your network administrator to make sure DHCP and DNS servers are linked together.

If DNS server address is setup, all Host Names reported during weblink configuration (i.e. SMTP server IP, SNTP server IP, SNMP trap server IP, etc.) will be translated into IP addresses.

### 3.5 IP Address

Every active device connected to the TCP/IP network must have a unique IP address. This IP address is used to build a connection to the iServer.

All network devices like computers that use TCP/IP protocol to communicate with each other should have a unique 32-bit address called IP address. The IP address is divided into two portions, the network ID and the host ID. For instance, every computer on the same network uses the same network ID. At the same time, all of them have different host IDs. For more details about the IP address see **Appendix B**.

### 3.6 Port Number

All TCP connections are defined by the IP address and a port number. A port number is an internal address that provides a TCP/IP interface between an application software on a computer and a device on the network or between two devices on the network.

There are two default TCP port (socket) numbers assigned to the iServer:

- 1) **Port 2000:** Once a TCP connection is made to the iServer using port 2000 or any port number that is configured on the iServer for Local Port (see Network menu, **Section 4.4.2**), the iServer can then be polled for variables like temperature, humidity, etc. using commands. For the list of commands see **Section 4.9.1**.
- 2) **Port 2002:** This port is the iServer's network console port for reading or changing the settings within the iServer. For the list of settings refer to **Section 4.8.1**. For both of the above cases, for example, a Telnet application can be used.

## PART 4 OPERATIONS

Depending on user's preference and network setup, the iServer can be configured in several ways:

Using the latest versions of Web browsers like Internet Explorer, Firefox, Opera, or Safari (iPhone) the iServer's Web server can be accessed, see **Section 4.2**.

It can also be configured using a TCP connection to port 2002 using a command line interface, see **Section 4.8.1**.

The iCONNECT Configuration Software can also be used to find and configure the iServer over the Ethernet, see **Section 4.1.2**.

**Note**

Before you configure the iServer, you will need to assign an IP address to the unit. Refer to **Section 4.1.1**, **4.1.2** or **4.1.3**.

### 4.1 IP Address Assignment

#### 4.1.1 DHCP (Method 1)

The DHCP server will assign an IP address, see **Section 3.3**.

#### 4.1.2 ARP HTTPget Commands (Method 2)

You can download the HTTPget program from our web site to use it for this section.

1. From the Command line (DOS prompt) where you keep the HTTPget.exe file, type the following:

```
arp -s 128.100.101.76 00-03-34-00-9c-5c      press the <Enter> key  
128.100.101.76, for example, is the IP address that you want to assign to your iServer  
and 00-03-34-00-9c-5c is the MAC address of your iServer labeled on the bottom of the  
unit.
```

2. From the same prompt, type the following HTTPget command:

```
httpget -r -S "00000000" 128.100.101.76:1  press the <Enter> key  
00000000 is the default ADMINISTRATOR password in your iServer unit and  
128.100.101.76:1 is the IP address that your iServer will accept on TCP port 1. At this  
point, you have successfully assigned 128.100.101.76 IP address to your iServer.
```

Continued on the following page.

### 4.1.2 ARP HTTPget Commands (Method 2) (continued)

**Note**

The above IP address of 128.100.101.76 is an example to show how these commands work. To get a valid IP address on your network you need to consult with your IT department.

**Figure 4.1** shows the screen shot of an actual DOS window with the above commands executed.

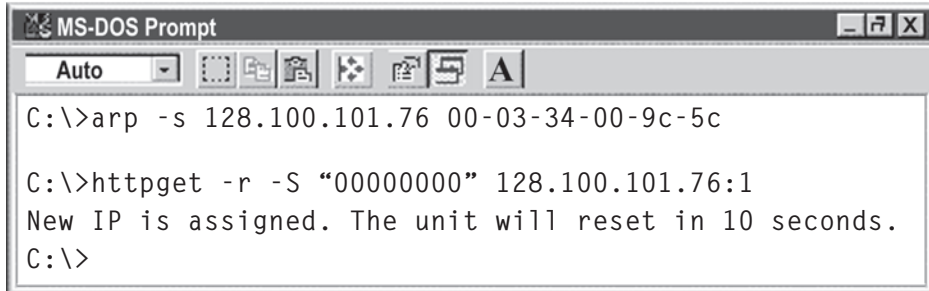
A screenshot of an MS-DOS Prompt window. The title bar reads "MS-DOS Prompt". The window contains the following text:

```
C:\>arp -s 128.100.101.76 00-03-34-00-9c-5c

C:\>httpget -r -S "00000000" 128.100.101.76:1
New IP is assigned. The unit will reset in 10 seconds.
C:\>
```

**Figure 4.1 ARP and HTTPget Commands on a DOS Window**

### 4.1.3 Direct Connection (Method 3)

The iServer is shipped with a default IP address of **192.168.1.200** and Subnet Mask of **255.255.255.0**.

To start, connect your iServer directly to your PC using a straight or cross-over Ethernet cable and power it on.

Make sure that the Network LINK/ACT LED on the iServer and your Ethernet switch is solid ON. Refer to **Figure 4.2**.

If you are going to use a Web browser or Telnet program to access the iServer using its default IP address of 192.168.1.200, you need to make sure that the PC from which you're establishing the connection has an IP address that is in the same range as the iServer's IP address.

For example, you can assign your PC an IP address of **192.168.1.x**, where **x** is any number from **1** to **254**.

**Note**

Your PC's IP address cannot be the same as the iServer's IP address.

You also need to make sure that your PC's subnet mask is **255.255.255.0**.

This is a good way to access the iServer over the network and make any configuration changes needed.

Changing your PC's IP address is **temporary** and it's only for the purpose of accessing the iServer for initial configurations like assigning a new IP address, subnet mask, etc.

Once the iServer is configured you can **put your PC back to its original IP settings**.

If 192.168.1.200 is already in use on your network, connect the iServer directly to your computer using a CAT5 Ethernet cable (either straight or cross-over cable will be detected by the iServer) and proceed as described below.

### 4.1.3 Direct Connection (Method 3) (continued)

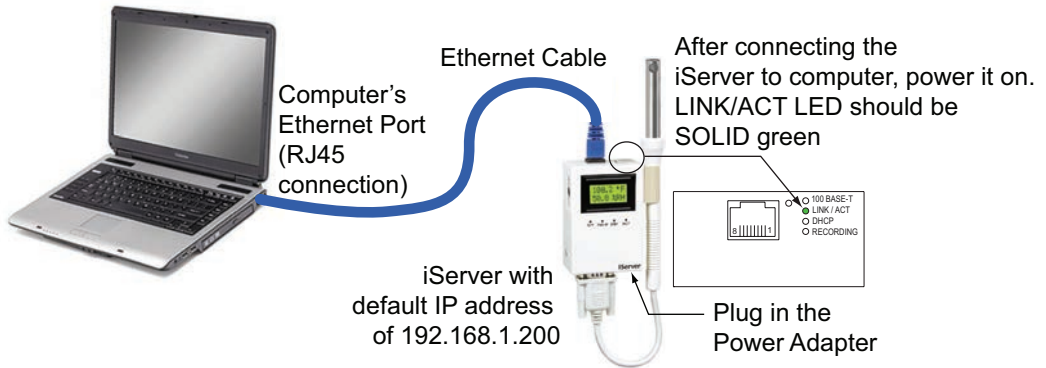

Figure 4.2 Connecting Computer Directly to iServer

1) Click on your Windows “Start” menu and select “Control Panel” from the list options.

Double click on the “Network Connections” icon

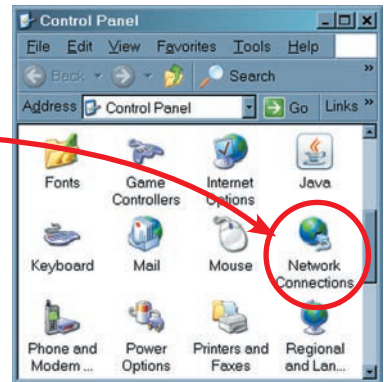

Figure 4.3 Network Connections

2) You now have “Network Connections” window opened.

The “Local Area Connection” icon has all the settings for your ethernet connection.

Double click on this icon.



Figure 4.4 Local Area Connection

### 4.1.3 Direct Connection (Method 3) (continued)

3) Click on **“Properties”** button

Select **“Internet Protocol (TCP/IP)”** and click on **“Properties”** button

Fill out the feilds for the IP address 192.168.1.100 and Subnet mask 255.255.255.0 as indicated below. Press OK and also on all other remaining windows.

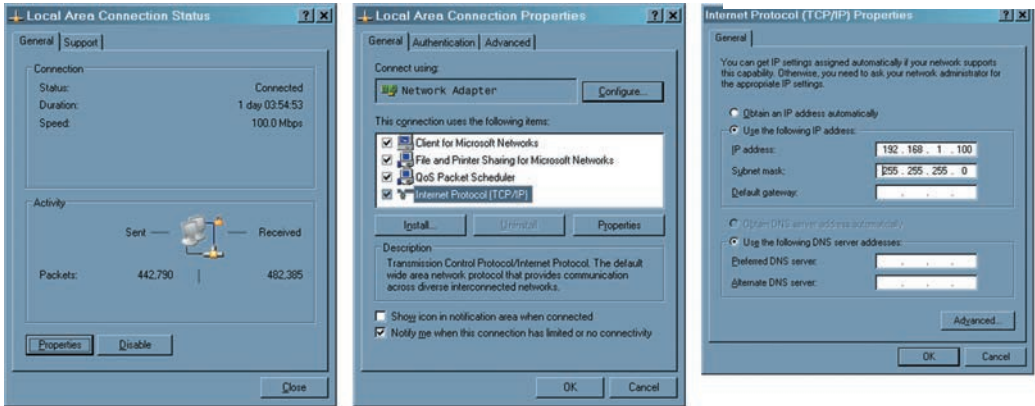

**Figure 4.5 Changing TCP/IP Properties on Your Computer**

- 4) Now you may need to reboot your computer.
- 5) Once your PC is back up, open your browser and type the iServer’s default IP address of **192.168.1.200** in the “Address” window of your browser and press the Enter key.

You will soon be inside the Welcome page (see **Figure 4.6**) of the iServers WEB server and from there you can access all the menus.

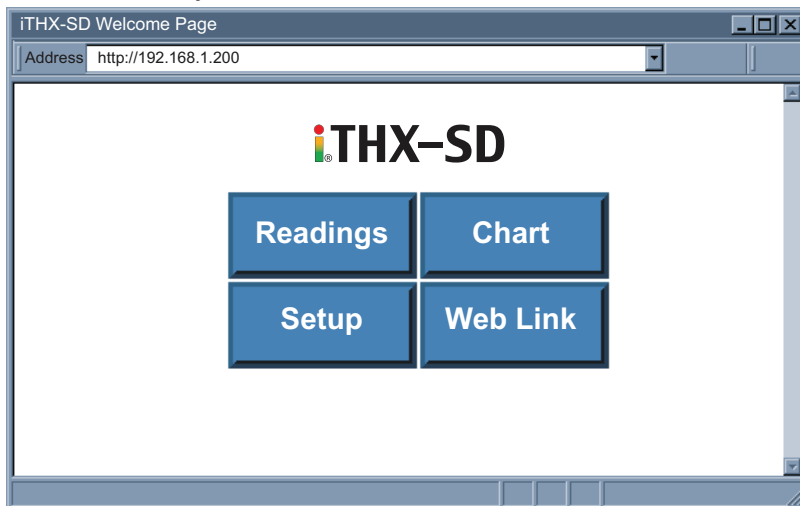

**Figure 4.6 iServer Welcome Page**

### 4.1.3 Direct Connection (Method 3) (continued)

**Note**

To verify a good connection to the iServer, from a DOS prompt on your computer type “**ping 192.168.1.200**” and press Enter.

You should get a reply as shown in **Figure 4.7**.

If you don't receive a reply it means that you do not have a network connection between your PC and the iServer.

Check your IP address, subnet mask, and gateway address.

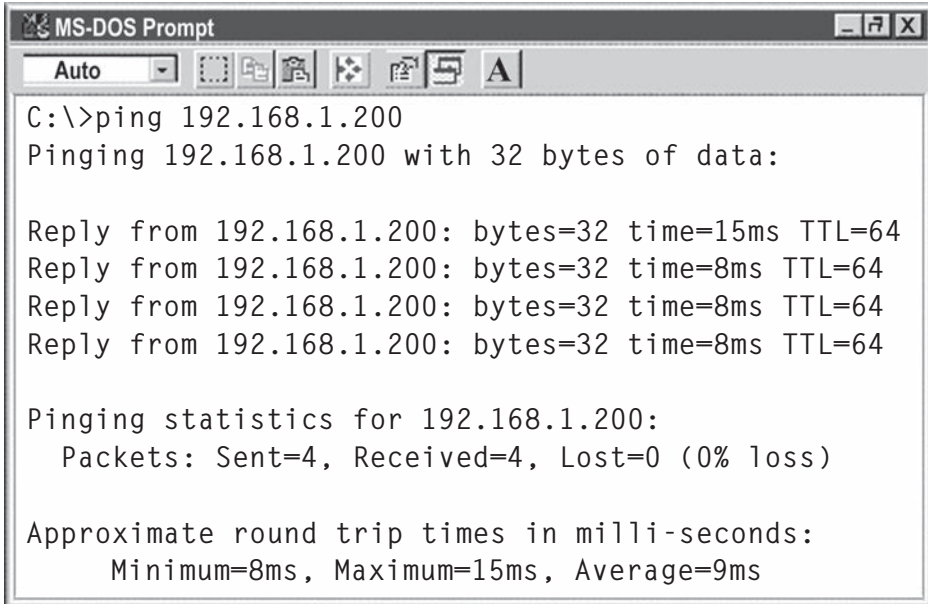

```
MS-DOS Prompt
Auto
C:\>ping 192.168.1.200
Pinging 192.168.1.200 with 32 bytes of data:

Reply from 192.168.1.200: bytes=32 time=15ms TTL=64
Reply from 192.168.1.200: bytes=32 time=8ms TTL=64
Reply from 192.168.1.200: bytes=32 time=8ms TTL=64
Reply from 192.168.1.200: bytes=32 time=8ms TTL=64

Pinging statistics for 192.168.1.200:
    Packets: Sent=4, Received=4, Lost=0 (0% loss)

Approximate round trip times in milli-seconds:
    Minimum=8ms, Maximum=15ms, Average=9ms
```

**Figure 4.7 Pinging the iServer from MS-DOS Prompt**

#### 4.1.4 iConnect Software (Method 4)

The iServer can be assigned an IP Address by using the iConnect software.

- a) Download the iConnect software from the website listed on the cover of this manual (software section).
- b) Install iConnect software on a networked PC. This software is compatible with Windows 95, 98, NT, 2000, and XP.
- c) Use iConnect to assign an IP address to the iServer and access its web pages for configuration.

You can also use any standard web browser to access the iServer's web pages. Consult with your IT department for obtaining an IP address.

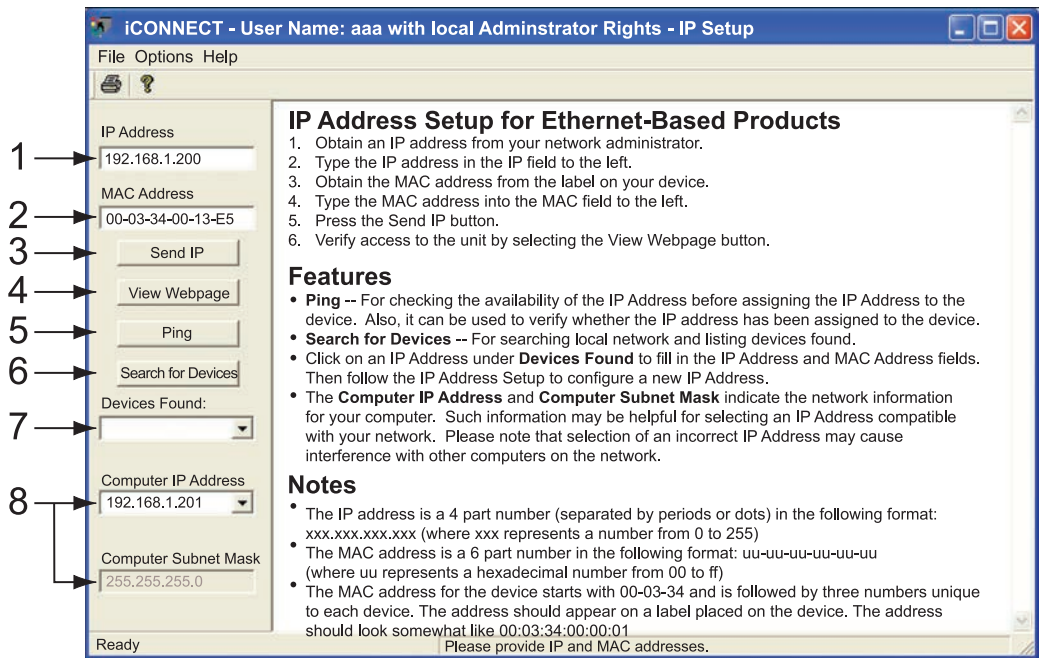

Figure 4.8 Assigning an IP Address using iConnect

- 1) Place the IP address in this box.
- 2) Take the MAC address from the label attached to the bottom of the iServer and place it in this box.
- 3) Click here to send the above IP address to the iServer.
- 4) After the IP address is assigned to the iServer, click here to access it's web pages.
- 5) Click here to Ping the iServer whose IP address is shown in the IP address box.
- 6) Click here to find all the iServer's on your network .
- 7) The IP addresses for the iServer's found by the iConnect will be listed here.
- 8) These fields indicate the IP address and the subnet mask of the PC on which the iConnect is running.

#### 4.1.4 iConnect Software (Method 4) (continued)

d) To access the iServer for Configuration:

Click on the “View Webpage” button, you will access the iServer’s welcome page.

To take advantage of the iServer’s full capability use any standard web browser to access the iServer’s web pages as described in **Section 4.2**.

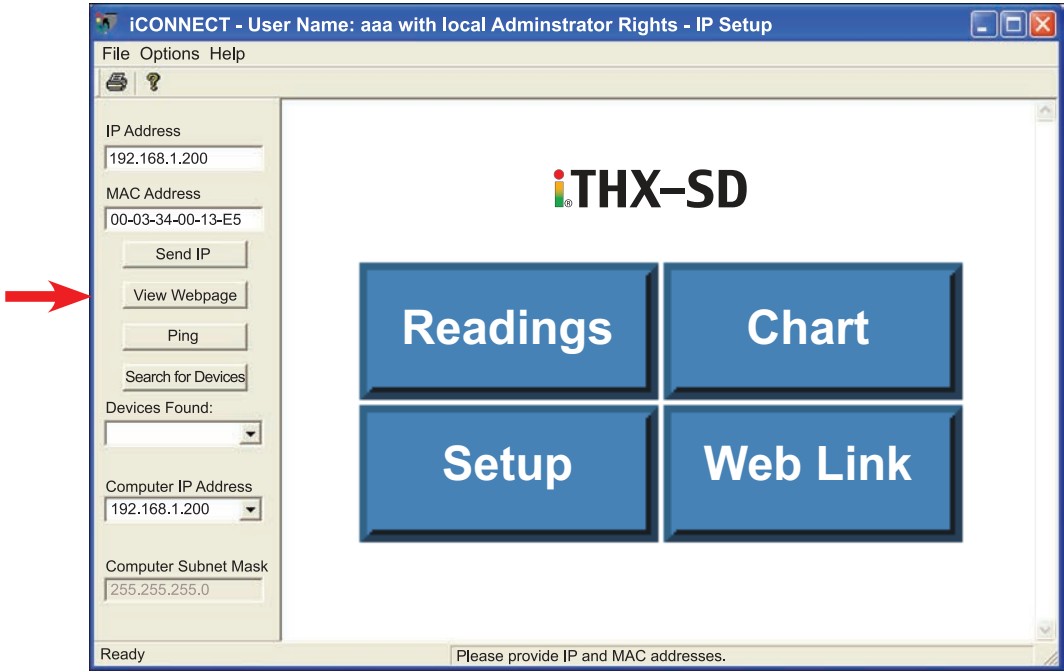

**Figure 4.9 Accessing the iServer’s using iConnect**

## 4.2 Access and Configuration Using a Web Browser

- Start your web browser.
- In the URL field, type **http://192.168.1.200** (iServer's default IP address).
- The Welcome Page, will be displayed.

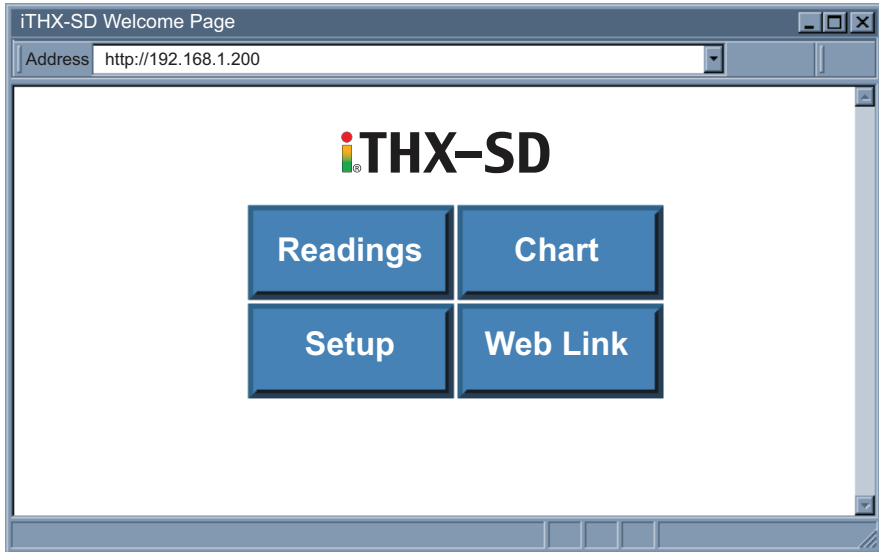
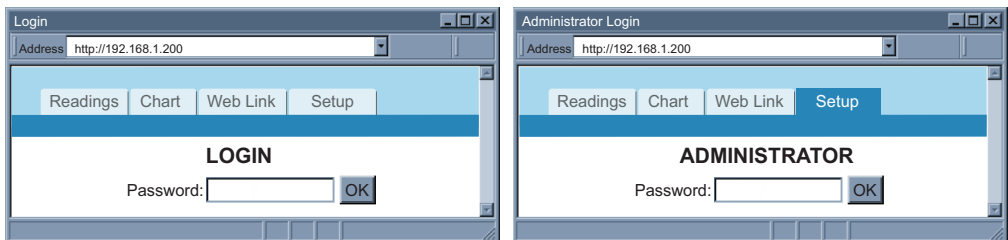

**Figure 4.10 iServer Welcome Page**

**Note**

In order to access the iServer's web pages, users may be prompted for a password, as shown below.

## 4.3 LOGIN and ADMINISTRATOR Passwords



**Figure 4.11 LOGIN and ADMINISTRATOR Passwords**

There are 2 different access levels:

1. LOGIN Password is required to access the iServer's Readings, Chart, and Web Link pages unless it's disabled. The default password is **12345678**.
2. ADMINISTRATOR Password is required to access the iServer's Setup menu unless it's disabled. The default password is **00000000**.

Refer to **Section 4.4.5** for Password setup.

## 4.4 Setup

Clicking the Setup button on the Welcome page (see **Figure 4.10**) will provide access to the Menu Panel (see **Figure 4.12**).

Using this Panel you can configure the iServer entirely.

### 4.4.1 Overview

Once the Administrator password is entered, the Overview page will appear which provides a summary of important parameters within the iServer.

All the fields are read-only.

Menu Panel	Parameter	Value
Overview	Model	iTHX-SD
Network	Firmware Version	x.x
Configuration	DHCP	Disabled
Management	MAC Address	00:03:34:00:b8:70
Security	IP Address	192.168.1.200
Recording	Subnet Mask	255.255.255.0
System	Gateway Address	0.0.0.0
Diagnostics	Hostname	ithxb870
Log Out	Ethernet Port	Auto
	Web Server Port	80
	Recording	<b>OFF</b>
	Uptime	1 day, 00:00:00 hh:mm:ss

**Figure 4.12 Overview**

## 4.4.2 Network

This menu provides network configurations including IP parameters and Ethernet interface options. Fields are described below.

### 4.4.2.1 IP Configuration

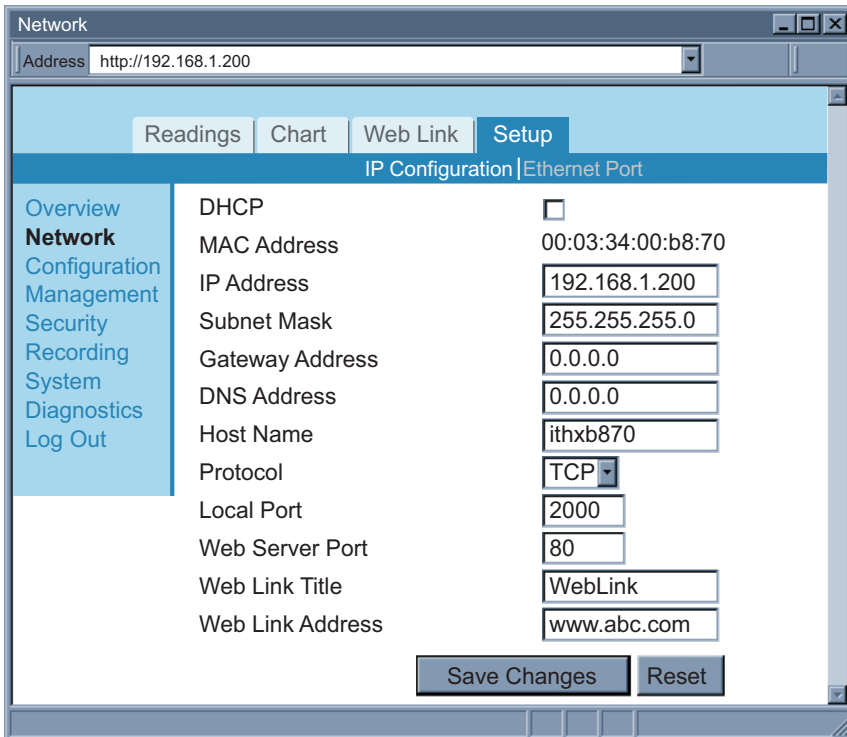

The screenshot shows a web browser window titled "Network" with the address bar displaying "http://192.168.1.200". The interface has a navigation menu on the left with options: Overview, Network (selected), Configuration, Management, Security, Recording, System, Diagnostics, and Log Out. The main content area is titled "IP Configuration | Ethernet Port" and contains the following settings:

DHCP	<input type="checkbox"/>
MAC Address	00:03:34:00:b8:70
IP Address	192.168.1.200
Subnet Mask	255.255.255.0
Gateway Address	0.0.0.0
DNS Address	0.0.0.0
Host Name	ithxb870
Protocol	TCP
Local Port	2000
Web Server Port	80
Web Link Title	WebLink
Web Link Address	www.abc.com

At the bottom of the form are two buttons: "Save Changes" and "Reset".

**Figure 4.13 Network: IP Configuration**

**DHCP** – If the box is checked the iServer will dynamically request an IP address, a subnet mask, a gateway address, and a DNS address from the DHCP server. By default the DHCP option is *disabled*. For more information about DHCP, see **Section 3.3**.



DHCP can be enabled by pressing and holding the two front buttons °C/F and TIME/IP during power-on (refer to **Section 2.3**).

**MAC Address** – This Indicates the hardware address of the iServer and it is non-configurable. For more information about MAC Address, see **Section 3.2**.

**IP Address** – This indicates the IP address of the iServer. The iServer's default IP address is *192.168.1.200*. When DHCP is enabled this field will be dimmed. Consult with your IT department for obtaining an IP address.

**Subnet Mask** – It's a 32-bit number that is used to determine which part of the IP address is the network portion and which part is the host portion. When DHCP is enabled this field will be dimmed. The iServer's default Subnet Mask is *255.255.255.0*. Consult with your IT department for obtaining a subnet mask.

#### 4.4.2.1 IP Configuration (continued)

**Gateway Address** – This points to the router that forwards traffic to a destination address outside of the subnet on which the iServer resides. This is the IP address of the router which functions as a gateway. When DHCP is enabled this field will be dimmed. The iServer's default Gateway address is *0.0.0.0*. Consult with your IT department for obtaining a gateway address.

**DNS Address** – In order to use the hostname to access the iServer, the DNS server on your network must be configured, refer to **Section 3.4**. iServer plays the role of a DNS client, in the sense that the iServer will actively query the DNS server for the IP address associated with a particular domain name. When DHCP is enabled this field will be dimmed. The iServer's default DNS address is *0.0.0.0*. Consult with your IT department for obtaining a DNS address.

**Host Name** – If DHCP is enabled, the iServer will send this name to the DHCP server. This name is used so that the iServer can be accessed based on a specific name instead of an IP address. For example, instead of using ***http://192.168.1.200*** (IP address), you would use ***http://ithxA838*** or any name up to sixteen (16) alphanumeric characters. The default Host Name for an iServer is "*ithx*" followed by the *last four digits* of the MAC address of that particular iServer.

**Note** 

On Windows servers where DHCP and DNS are separate functions it's very important to configure the DHCP server to communicate with DNS in order for the iServer's Host Name to correctly respond. If you cannot access the iServer using its Host Name, please contact your network administrator to make sure DHCP and DNS servers are linked together.

**Protocol** – It's the network protocol the iServer communicates with the Ethernet Network. Options are *TCP* and *UDP*. The default is *TCP*.

**Local Port** – The default port is *2000*. Refer to **Section 3.6**.

**Web Server Port** – The default port is *80*. This is the primary port number for the HTTP protocol used for communication between internet browsers and web sites/web servers. Web servers open this port then listen for incoming connections from web browsers. Similarly, when a web browser is given an IP address (like the iServer's IP address), it assumes that the iServer's web server is listening for connections on port 80. If this port is changed to anything but 80 then on the browser the new port number must be indicated with a colon (:) after the IP address. For example, if the Web Server Port is changed to **500**, you will then need to type ***http://192.168.1.200:500*** on the browser to access the iServer's web server.

**Note** 

One of the applications where the Web Server Port number may need to change is when users want to access the iServer's web server from outside the local area network (i.e. Internet). By setting up "Port Forwarding" inside a router that is the gateway to that local area network this task can be accomplished. "Port Forwarding" technique uses the Web Server Port number to forward the Internet connection to the iServer on the LAN.

**Web Link Title** – This is a text field that appears on the button on the iServer's Web Link Page, refer to **Section 4.7**. This can describe the Web Link Address assigned below.

**Web Link Address** – This provides a link to any TCP/IP node on the network or any Web link on the Internet. Examples would be ***www.123abc.com*** or if you have a device with an embedded Web server (just like the iServer) once you enter its IP address in this field and click on the Web Link button on the iServer's Welcome page you'll be able to access your device using the same browser interface.

## 4.4.2.2 Ethernet Port

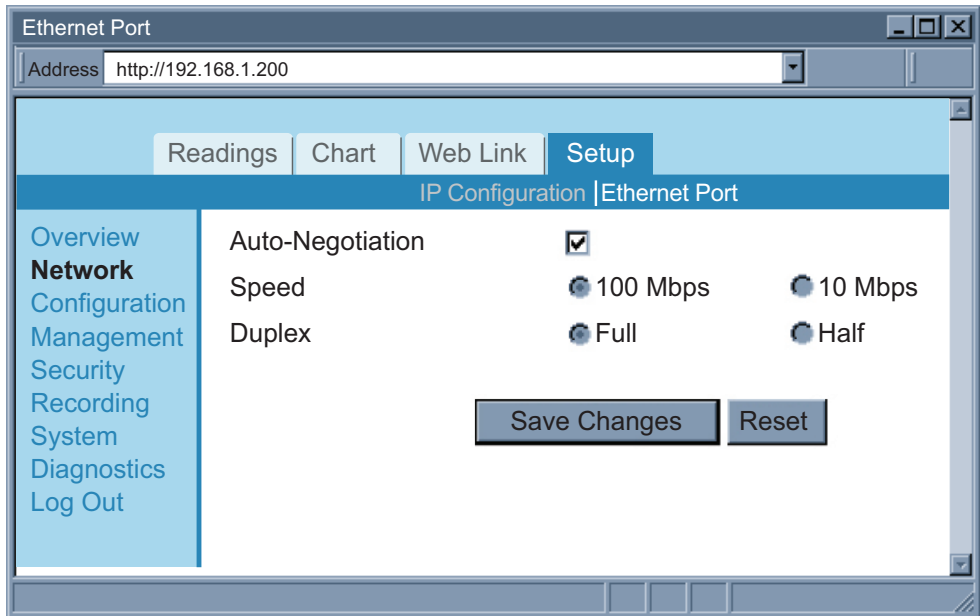

**Figure 4.14 Network: Ethernet Configuration**

**Auto-Negotiation** – It is the link, in terms of speed and duplex, between the iServer and another Ethernet device like an Ethernet switch.

If Auto-Negotiation box is checked, the iServer will auto-negotiate the speed and duplex with the attached Ethernet device. If any of the other options are selected, the speed and duplex will be fixed.

It's important to have the same Ethernet port configuration on the iServer and the attached Ethernet device. If iServer cannot auto-negotiate with the attached Ethernet node it will default to *10 Mbps* and *Half-Duplex*. Once Auto-Negotiation is checked, other fields under this category will be dimmed. By default the Auto-Negotiation is *checked*.



If the iServer detects the link to be 100 Mbps the 100 BASE-T LED will be solid green.

## 4.4.3 Configuration

This menu provides configurations for the real-time clock, server parameters, sensors, and alarm relays settings. Fields are described below.

### 4.4.3.1 Date and Time

**Current Date** – This field indicates the iServer's real time clock date. The format is *yyyy/mm/dd*. When there is no date defined, the iServer will be defaulted to *2099/01/01* and be shown in red to alert you that it has not yet been set.

**Current Time** – This field indicates the iServer's real time clock time. The format is military time (24-hour) and it is entered as *hh:mm:ss*.

**Change Date and Time** – By clicking on this option the real data and time can be entered.

### 4.4.3.1 Data and Time (continued)

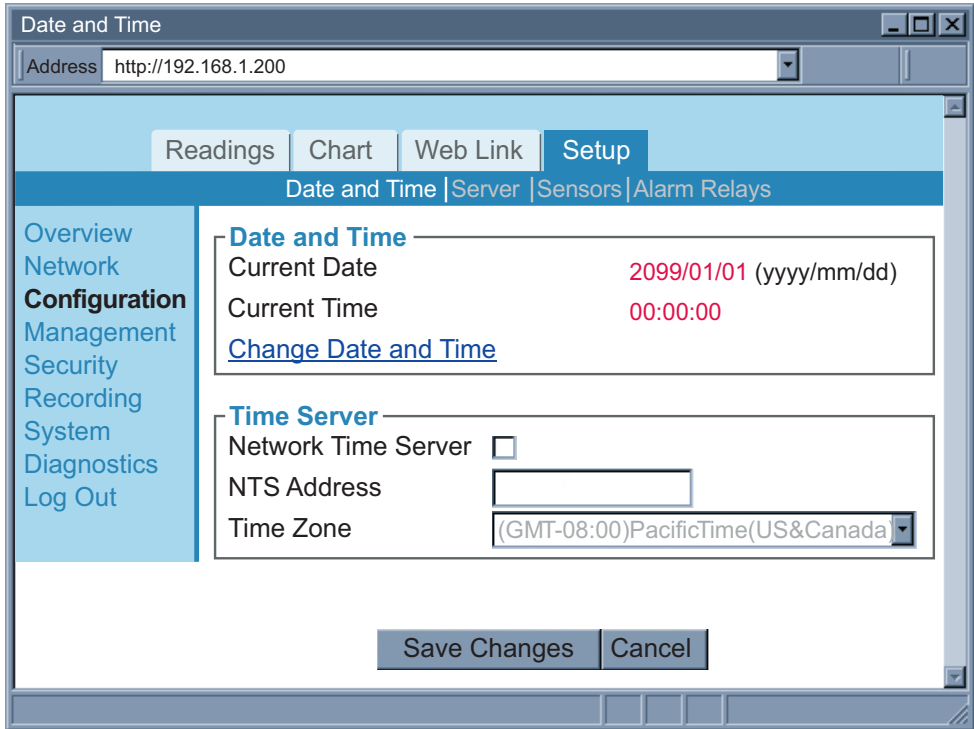

**Figure 4.15 Network: Ethernet Configuration**

**Note** 

Once the AC adaptor is disconnected from the iServer and there is no battery back-up, the iServer will lose its date and time settings.

**Note** 

Once the iServer is rebooted from any web page, the iServer will lose its date and time settings whether or not the back-up battery is installed.

**Tip** 

If the iServer is setup to get it's time from a Network Time Server, then the time will be re-assigned after the reboot.

**Network Time Server** – If there is a time server on the network or the Internet, the iServer will get the real date and time once the Network Time Server's IP address is provided. Default is *unchecked*.

**NTS Address** – The field to enter the Network Time Server's IP address.

The U.S. National Institute of Standards and Technology (NIST) publishes a list of time servers on the Internet used by the NIST Internet Time Service (ITS). The list includes each server's name, IP address, and location in the United States. As of the publication date of this manual, links to the list can be found at <http://tf.nist.gov>.

**Time Zone** – If Network Time Server option is checked, the correct time zone must be selected for the correct time display.

### 4.4.3.2 Server

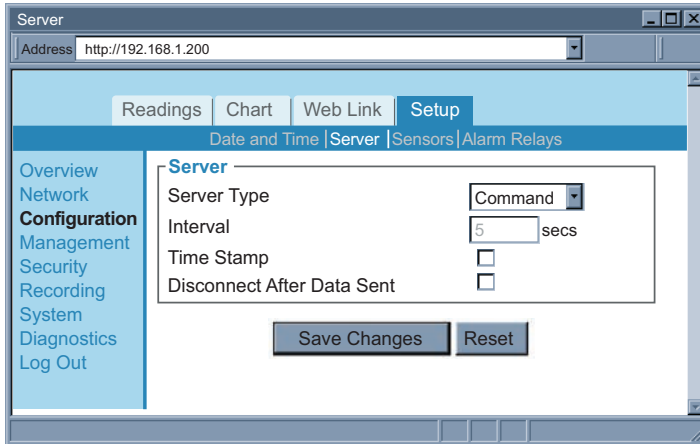

**Figure 4.16 Configuration Menu: Server**

**Server Type** – Options are *Command* and *Continuous*.

If *Command* is selected the iServer will respond to commands sent from a network host (for the list of commands refer to **Section 4.9.1**).

If *Continuous* is selected the iServer will send temperature, humidity, dewpoint values and alarm relay status once every time amount selected in the Interval box.

The *Command* and *Continuous* modes operate when a network host opens a TCP connection to the iServer's IP address with port 2000.

In UDP *Command* mode, iServer will respond back with a UDP packet (to the \_ address and port) if a host application sends a UDP command to iServer's IP address with port 2000.

In UDP *Continuous* mode, iServer starts sending continuous data if a host application sends a trigger or UDP packet to iServer's IP address with port 2000.

**Interval** – This is the time interval (in seconds) between each data transmission when the iServer is in *Continuous* mode. The default value is set to *5 seconds* and the minimum is *2 seconds*.

**Time Stamp** – If checked, the iServer will stamp the data with date and time before sending it out to a network host. This will apply to *Command* and *Continuous* modes. Default is *unchecked*.

**Disconnect After Data Sent** – If checked, once the iServer responds back with data, the iServer will close the TCP connection that had been made from the network host. This feature should be used if data acquisition software expects data to be ended by closing TCP connection from the client.

### 4.4.3.3 Sensors

This is the page where the Sensor Parameters are defined. Reading 1 is for Temperature, Reading 2 is for Humidity, and Reading 3 is for Dewpoint.

**Enabled Probes** – Choose *Both Probes* if you have two probes (sensors). Choose *Only Probe 1* if you just have one probe, or if you have two probes but only want to show *Probe 1*. Default is *Both Probes*.

**Degree Unit** – This would be the units of measurement for the probe sensor. Examples are F and C for temperature and dewpoint. Once the unit of temperature is selected, either C or F, it will be a global change throughout the web server, as well as on the LCD display. If you use the front C/F buttons to change the unit of temperature it will have no effect on the web pages.

### 4.4.3.3 Sensors (continued)

**End Character** – This means that the iServer will send a character (in Hex) after the value for each variable. This will apply to either Continuous or Command mode. Once the value is selected, it will be a global change for all readings. The default is set for 0D (Hex representation of <CR>).

**Description** – This can be a name for the sensor or where the sensor is located. This field is text only and can have up to 16 alphanumeric characters. This description will appear wherever Reading 1, 2 or 3 is displayed on the web server.

**Unit** – This would be the units of measurement for that particular sensor. Examples are % for humidity, *F* and *C* for temperature and dewpoint. Once the unit of temperature is selected, either *C* or *F*, it will be a global change through out the web server, as well as on the LCD display. If you use the front **C/F** buttons to change the unit of temperature it will have no affect on the web pages.

**Note** The adjusting values must be assigned after the unit of temperature (C or F) is selected. If the unit of temperature is changed, you must readjust the values for a correct result.

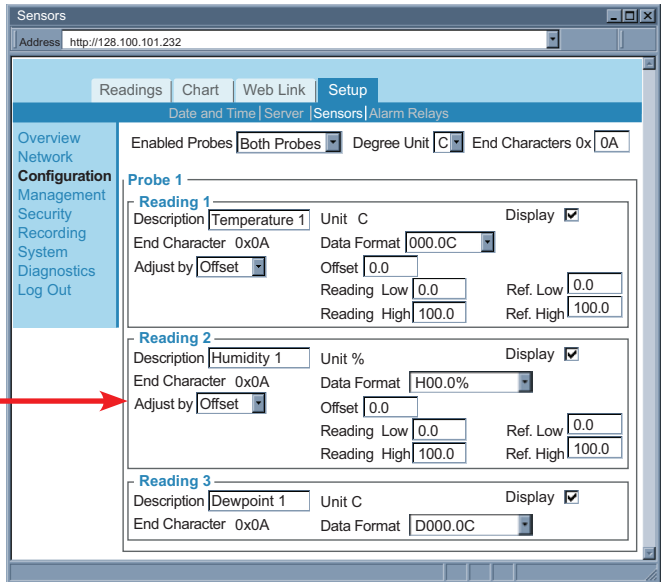

**Figure 4.17a Configuration Menu: Sensors**

**Display** – If checked the variable (i.e. temperature) will be displayed on the Readings and Chart applets as well as data transmission in *Continuous* mode (see Server Section 4.4.3.2). The default is *checked*.

**Data Format** – This indicates the format of the variable being displayed on a network host when *Continuous* or *Command* transmission is used. Reading 1: *T000.0C, 000.0C, 000.0*; Reading 2: *H00.0%, 00.0%, 00.0* (the *C* or *F* will change to the appropriate *unit* once you press Save Changes button).

**Adjust by** – If it's determined that the reading is slightly off this field can be used to adjust the reading. The options are *Offset* and *Scale & Offset*. Using the *Offset* method you can manually assign a numerical value to adjust the reading.

For example if the actual reading is 55 where it should be 54 you can enter -1 in the *Offset* field. The *Scale & Offset* method uses two points to adjust the reading within the entire temperature range. For example, if at the lower point the actual reading is 10 where it should be 12 and at the higher point the actual reading is 200 where it should be 195, here is how the numbers are entered. The adjusting numbers can be positive or negative with one decimal point.

Reading Low	<input type="text" value="10.0"/>	Ref. Low	<input type="text" value="12.0"/>
Reading High	<input type="text" value="200.0"/>	Ref. High	<input type="text" value="195.0"/>

### 4.4.3.3 Sensors (continued)

**Offset** – If it's determined that the reading is slightly off, this field can be used to manually assign a numerical value to adjust the reading. The offset can be a positive or a negative number with one decimal point.

**Note** The temperature offset value must be assigned after the *Unit* (C or F) is selected. If the unit of temperature is changed, you must reassign the offset value for the correct result.

**Sampling Rate** – This determines the rate in which the iServer polls the probe for temperature and humidity values. The options are *1, 10, and 60 seconds*. The default is set for *10 seconds*.

**Note** The higher the sampling rate, the more accurate data is transmitted by the probe.

**LCD Display – Probe to Display** - This dropdown box is only available when Both Probes are enabled (on Enabled Probes drop down box). If you only have 1 probe then probe 2 will be shown as OPEN on the readings page, chart and recorded data.

The screenshot shows a web browser window titled "Sensors" with the address "http://192.168.1.200". The configuration menu is organized into several sections:

- Probe 2** (expanded):
  - Reading 1**: Description "Temperature 2", Unit "C", Display checked. End Character "0x0A", Data Format "000.0C", Offset "0.0", Reading Low "0.0", Reading High "100.0", Ref. Low "0.0", Ref. High "100.0". Adjust by "Offset".
  - Reading 2**: Description "Humidity 2", Unit "%", Display checked. End Character "0x0A", Data Format "H00.0%", Offset "0.0", Reading Low "0.0", Reading High "100.0", Ref. Low "0.0", Ref. High "100.0". Adjust by "Offset".
  - Reading 3**: Description "Dewpoint 2", Unit "C", Display checked. End Character "0x0A", Data Format "D000.0C".
- Sampling Rate**: One Sample per "1 second".
- LCD Display**: Probe To Display "Both Probes".

Buttons for "Save Changes" and "Reset" are located at the bottom of the form.

Figure 4.17b Configuration Menu: Sensors

### 4.4.3.4 Alarm Relays

**Note** This section would allow the two relays on the iServer to be configured as needed. For physical connections and pin-outs refer to **Section 2.6**.

**Relay 1 and Relay 2** – This configures the first and second relays on the iServer. The options for each are *temperature, humidity, and dew point*. This means that both Relays can be set for *temperature* or both Relays can be set for *humidity*, or one can be set for *humidity* and one for *temperature*.

**Description** – This is a text field for naming the device connected to the relay or it could be the location where the device is installed. This field can take up to 16 alphanumeric characters. This name will be displayed anywhere on the web pages associated with alarm relays; for example the Readings applet. Defaults are *Alarm Relay1* and *Alarm Relay2*.

#### 4.4.3.4 Alarm Relays (continued)

Relay	Probe	Relay Description	Status	Type	Set Point High	Set Point Low	End Character	Display
Relay 1	1	R1alarm1	Low or High	Latch	101.0	30.0	0x0A	<input checked="" type="checkbox"/>
Relay 2	2	R2alarm2	Low or High	Latch	60.0	0.2	0x0F	<input checked="" type="checkbox"/>

**Note** Alarm status with the associated set point will be shown on the chart applet as well.

**Figure 4.18 Configuration Menu: Alarm Relays**

**Status** – The options are *Disable*, *Low*, *High*, and *Low or High*. The default is *Disable*. If *Low* is selected Set Point Low must be given a value and once the sensor reading falls below that value the relay will change status. If *High* is selected Set Point High must be given a value and once the sensor reading rises above that value the relay will change status. If *Low or High* is selected Set Point Low and High must be given values and relay status will change once the sensor reading is outside that range. If *Disable* is selected relays will be deactivated.

**Type** – The options are *Unlatch* and *Latch*. The default is *Unlatch*.

If *Unlatch* is selected and the relay is activated, once the sensor reading goes back within the Set Point range, the alarm will be deactivated automatically.

If *Latch* is selected, once the sensor reading goes back within the Set Point range, the relay will remain active until the user clears it by clicking on the Clear Latch button.

**Set Point High** – This is the field for the upper Set Point.

**Set Point Low** – This is the field for the lower Set Point.

**End Character** – This is the character (in Hex) that the iServer will send along with the alarm status.

This applies to either *Command* and *Continuous* mode described on the Server page, under the Configuration menu (**Section 4.4.3.2**).

The default is *0D* meaning a Carriage Return character will be sent after the value.

**Display** – This would indicate whether to display the status of the alarm relays on the Readings applet as well as the TCP *Command* and *Continuous* modes, and any other related fields. The default is *unchecked*.

**Record all alarm events on the flash memory** – If checked, all the alarm events with stamped date and time will be recorded on the flash memory card.

By pressing the Retrieve button the ASCII log file will be opened.

The default is *unchecked*.

**Note** Using the web server, the log file can be retrieved if the file size is 32 KB or smaller. For a larger file size you must use a flash card reader to open the log file. Refer to **Section 4.10**.

#### 4.4.4 Management

This page provides the iServer's email, SNMP and alarm settings. SNMP (Simple Network Management Protocol) is the protocol used by network management systems to communicate with network devices that respond to SNMP connections for the purpose of problem detections and corrections.

If SNMP and/or SMTP features are desired, please make sure iServer's network setting as well as SNMP trap server and SMTP mail server are setup properly. Failure to do so may cause iServer to be unresponsive while waiting for these servers to reply back. Fields are described below.

##### 4.4.4.1 Setup -

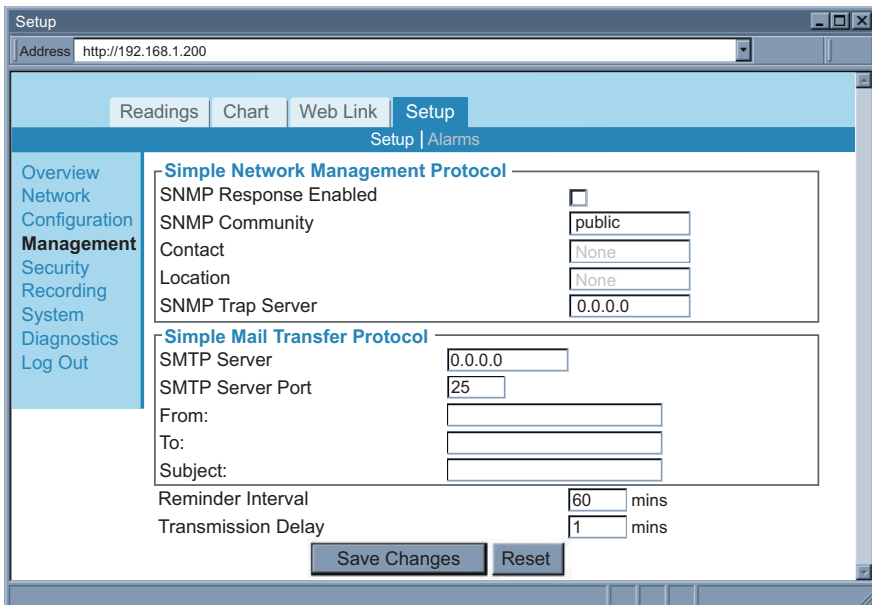

The screenshot shows a web browser window titled "Setup" with the address bar displaying "http://192.168.1.200". The page has a navigation menu on the left with options: Overview, Network, Configuration, Management (highlighted), Security, Recording, System, Diagnostics, and Log Out. The main content area is titled "Setup | Alarms" and contains two sections:

- Simple Network Management Protocol**: Includes a checkbox for "SNMP Response Enabled" (unchecked), a text field for "SNMP Community" (value: public), a text field for "Contact" (value: None), a text field for "Location" (value: None), and a text field for "SNMP Trap Server" (value: 0.0.0.0).
- Simple Mail Transfer Protocol**: Includes a text field for "SMTP Server" (value: 0.0.0.0), a text field for "SMTP Server Port" (value: 25), and three text fields for "From:", "To:", and "Subject:". Below these are two numeric input fields: "Reminder Interval" (value: 60) and "Transmission Delay" (value: 1), both with "mins" units.

At the bottom of the form are two buttons: "Save Changes" and "Reset".

Figure 4.19 Management Menu: Setup

#### Simple Network Management Protocol

**SNMP Response Enabled** – If this option is checked the iServer will respond to network nodes broadcasting SNMP requests. The default is *unchecked*.

Make sure your network is setup properly (gateway, etc) before using SNMP feature

**SNMP Community** – Every SNMP communication takes place using a community string. The default is *Public*.

**Contact** – This text field specifies the contact person for this node, together with information on how to contact this person. This field takes up to 16 alphanumeric characters.

**Location** – This text field specifies the location of the iServer. For example it can be "control station", which is the place where the iServer is located. This field takes up to 16 alphanumeric characters.

#### 4.4.4.1 Setup (continued)

**SNMP Trap Server** – This field contains the IP address of the SNMP trap server located somewhere on the network. The trap server listens for SNMP traps coming from the iServer when there is an alarm condition (refer to Alarms **Section 4.4.4.2** under the Management page).

#### Simple Mail Transfer Protocol

**SMTP Server** – This field specifies the IP Address of the SMTP server.

**Note** ⓘ

- 1) You must have an email server (SMTP server) on your network in order to receive emails generated by the iServer.
- 2) iServer does not support SMTP server authentication.

**SMTP Server Port** – This specifies the TCP port used by the SMTP Server. The default is 25.

**From** – This field specifies the name of the person who sends the email. It can also be an email address.

**To** – This field specifies the email address of the recipient. This field can take up to 200 alphanumeric characters; limited to 4 addresses of 50 characters each. Each address should be separated by a comma, without spaces. **Ex: aaa@bbb.com,ccc@ddd.com**

**Tip** ⓘ

You can create a “distribution group address” if you need to have more email addresses.

**Subject** – This field specifies the subject of the email. Emails for all the alarms will have this common subject line. Example of a subject can be “Alarm from iServer”.

**Reminder Interval** – This field sets a reminder interval for email and/or trap to be sent again. The allowed minimum value is 1 minute. If it’s set to 0 the iServer will not send a reminder email. The default is *60 minutes*.

Power Reset alarm is only sent once, regardless of reminder interval.

**Transmission Delay** – Once the iServer alarm condition is met, this is the amount of time the alarm condition is met before iServer sends any email or trap. If it’s set to 0, email and/or trap will be sent immediately. The default is *1 minute*.

#### 4.4.4.1.1 Sending Text Messages to a Cell Phone

In the SMTP **To** field, you can use the following format to have the iTHX-SD send a text message to your cell phone. Since most cell phones are capable of receiving text messages you just need to find the correct email format for your cell phone provider.

T-Mobile	phone_number@tmomail.net
Virgin Mobile	phone_number@vmobl.com
AT&T	phone_number@txt.att.net
Sprint	phone_number@messaging.sprintpcs.com
Verizon	phone_number@vtext.com
Nextel	phone_number@messaging.nextel.com

“phone\_number” is your 10 digit cell phone number.

#### 4.4.4.2 Alarms

This includes events or conditions. Once a condition is met the iServer will send an email or/and an SNMP trap if either one or both are checked. Fields are described below.

**Note** ⓘ

Multiple alarm events can be checked and for each event an email and/or a trap will be sent.

## 4.4.4.2 Alarms (continued)

Alarms

Address <http://192.168.1.200>

Readings | Chart | Web Link | Setup

Setup | Alarms

Overview  
Network  
Configuration  
**Management**  
Security  
Recording  
System  
Diagnostics  
Log Out

**Events** Email SNMP Trap

**Probe 1**

Temperature	Low	Low	0.0	High	0.0		<input type="checkbox"/>	<input type="checkbox"/>
Humidity	Low	Low	0.0	High	0.0		<input type="checkbox"/>	<input type="checkbox"/>
Dewpoint	Low	Low	0.0	High	0.0		<input type="checkbox"/>	<input type="checkbox"/>

**Probe 2**

Temp	Low or High	Low	0.0	High	0.0		<input type="checkbox"/>	<input type="checkbox"/>
Humi	Low or High	Low	0.0	High	0.0		<input type="checkbox"/>	<input type="checkbox"/>
Dew	Low or High	Low	0.0	High	0.0		<input type="checkbox"/>	<input type="checkbox"/>

**Device**

Power Reset		<input type="checkbox"/>	<input type="checkbox"/>
Probe 1 Disconnected		<input type="checkbox"/>	<input type="checkbox"/>
Probe 2 Disconnected		<input type="checkbox"/>	<input type="checkbox"/>
Recording Stopped		<input type="checkbox"/>	<input type="checkbox"/>
SD Card 10% Memory Left		<input type="checkbox"/>	<input type="checkbox"/>
Low Battery		<input type="checkbox"/>	<input type="checkbox"/>
Relay 1 Activated		<input type="checkbox"/>	<input type="checkbox"/>
Relay 2 Activated		<input type="checkbox"/>	<input type="checkbox"/>

Save Changes | Reset

**Note** There is a text box next to each event. The text content will be the body of the email.

**Figure 4.20 Management Menu: Alarms**

**Temperature** – The options are *Low*, *High*, and *Low or High*.

If *Low* is selected the Low field must be given a value (lower than that value is an alarm condition).

If *High* is selected the High field must be given a value (higher than that value is an alarm condition).

If *Low or High* is selected the Low and High fields must be given values (outside the band is an alarm condition).

**Humidity** – The same as Temperature defined above.

**Dew Point** – The same as Temperature defined above.

**Power Reset** – This refers to the iServer being powered off and back on (power reset). If the option is checked the iServer will automatically send one email or/and a SNMP trap after rebooting, regardless of reminder interval.

**Probe Disconnected** – If the probe attached to the iServer is disconnected that is considered as an alarm condition.

**Recording Stopped** – If the iServer is recording, once the recording is stopped (no matter what the cause was) an email or/and a trap will be sent.

**SD Card 10% Memory Left** – An alarm will be triggered if 10% or less memory left on the flash card.

**Low Battery** – If the 9V battery lowers to about 7V, the iServer will prompt an alarm.

**Relay 1 Activated** – If relay 1 is activated the iServer will prompt an alarm.

See Alarm Relays section under the Configuration page (**Section 4.4.3.4**).

**Relay 2 Activated** – If relay 2 is activated the iServer will prompt an alarm.

See Alarm Relays section under the Configuration page (**Section 4.4.3.4**).

#### 4.4.5 Security

This page provides security and access settings for the iServer. Fields are described below.

Security

Address

Readings Chart Web Link Setup

Overview  
Network  
Configuration  
Management  
**Security**  
Recording  
System  
Diagnostics  
Log Out

Login Password  [Change](#)

Admin Password  [Change](#)

Local Port Password  [Change](#)

Telnet Console Access

Web Server Access

Secured Readings and Charts

**IP Exclusivity**  Enable

No	IP Address
1	<input type="text" value="0.0.0.0"/>
2	<input type="text" value="0.0.0.0"/>
3	<input type="text" value="0.0.0.0"/>
4	<input type="text" value="0.0.0.0"/>

Save Changes Reset

Figure 4.21 Security Menu

**Login Password** – To access Readings, Chart, and Web Link menus this password is required. The password length can be up to 16 alphanumeric case-sensitive characters. To change the password click on *Change*.

Empty box means no password is required. The default Login Password is *12345678*.

**Administrator Password** – To access Setup menu this password is required. The password length can be up to 16 alphanumeric case-sensitive characters. To change the password click on *Change*.

Empty box means no password is required. The default Administrator Password is *00000000*.

**Note**

This password will also be prompted when Telnet connection to port 2002 is made. Port 2002 is the Telnet console port that allows users to configure some of the parameters that can be configured through the web server.

**Local Port Password** – To access the iServer via TCP or UDP socket connection to port 2000, this password is required. The maximum length can be up to 16 alphanumeric case-sensitive characters.

Empty box means no password is required. The default is *none*.

**Telnet Console Access** – If it is unchecked, Telnet console connection to port 2002 will be blocked. The iServer must be rebooted for the change to take place.

The default is *checked*.

**Web Server Access** – If it is unchecked, the iServer's Web server will not be accessible. The iServer must be rebooted for the change to take place.

The default is *checked*.

**Note**

When the Web Server Access is not enabled, the iServer needs to be configured using Telnet console.

If someone needs to access the Web Server again, use the Telnet console to enable it.

**Secured Readings and Charts** – If it is checked the Login password will be required to display Readings and Chart applets.

The default is *checked*.

**IP Exclusivity** – This table contains the IP addresses that are allowed to communicate with the iServer over TCP or UDP connection. This means if the table is empty connections from all IP nodes are allowed to the iServer.

If enabled, all packets from IP addresses not on this list are ignored and thrown away.

## 4.4.6 Recording

This section includes all the parameters and settings for data recording, SD flash card and recording status, data retrieval, and formatting the SD card.

Fields are described below.

### 4.4.6.1 Start Recording

The screenshot shows a web browser window titled "Start Recording" with the address "http://192.168.1.200". The interface includes a navigation menu on the left with options like Overview, Network, Configuration, Management, Security, Recording (selected), System, Diagnostics, and Log Out. The main content area has tabs for Readings, Chart, Web Link, and Setup. Under the Setup tab, there are sub-tabs for Start Recording, Status, Data Retrieval, and Format SD Card. The "Start Recording" sub-tab is active, displaying the current date and time (2099/01/01 and 00:00:00). It features several configuration fields: "Interval" (10 seconds), "Title" (empty), "Type" (Wrap), and "Category" (Continuous). A "Quick Start Recording" button is located below the Title field. The "Set Date and Time" section includes fields for Start Date, Stop Date, Start Time, and Stop Time. The "Set Weekdays" section has checkboxes for each day of the week. A "Start Recording" button is positioned at the bottom of the form.

**Figure 4.22 Recording Menu: Start Recording**

**Interval** – This is the time interval between each data. It can be between 1 to 3600 seconds.

**Title** – This is the header for each recorded data file on the SD flash card.

**Quick Start Recording** – If this button is clicked recording will start immediately.

Make sure your Current Date and Time are correct.

**Type** – The options are *Wrap* and *Non-Wrap*.

If *Wrap* is selected once the SD flash card is full the iServer will delete the old data stored on the card in order to record the new data. Each time a new recording takes place an old record will be deleted.

If *Non-Wrap* is selected the iServer will stop recording once the SD flash card is full.

#### 4.4.6.1 Start Recording (continued)

**Category** – The options are *Continuous* and *Scheduled*.

In *Continuous* recording Start Date and Start Time fields are required. If there is not an End Date and End Time, the recording will continue non-stop.

In *Scheduled* recording, any of the days can be selected and the recording will take place only on those days. Here are some important notes about the Scheduled recording:

- The *Start Date*, *Start Time*, and *Stop Time* must be defined. The *Stop Date* does not apply to Scheduled recording. This means that the Scheduled recording will never stop until the user decides to stop it.
- If the *Start Date* is one of the selected days recording will start on that day.
- If the *Start Date* is not one of the selected days recording will start on the next 1st selected day.
- The *Start Time* and the *Stop Time* apply to every single day that is selected.
- The *Start Time* is the time that recording will start on those selected days.
- The *Stop Time* is the time that recording will stop on those selected days.
- The *Start Time* must be earlier (at least 20 seconds) than the stop time.
- Let's say today we're configuring the unit for Scheduled recording. If the *Start Time* is earlier than the Current Time (real time clock) and today is one of the selected days, the recording will start immediately.
- Scheduled recording is suitable for users who want to start and stop recording at certain times on certain days. Users who want to have continuous recording three days a week, for instance, this feature can also be used. Just make sure to select start and stop times that would link the three days together.

For example, we need to have 3 days (72 hrs) a week continuous recording (Monday, Tuesday, and Wednesday) with recording Interval of 1 minute. The *Start Time* should be 00:00:00 and the *Stop Time* should be 23:59:00. This will connect all 3 days together and it will run on weekly bases.

**Start Date** – This is the date on which the data recording must start.

**Start Time** – This is the time that the recording will start. It's based on a 24-hour format. The *Start Time* must be at least twenty seconds after the Current Time (real time).

**Stop Date** – This is the date on which the data recording will stop. *Stop Date* does not apply to Scheduled recording.

**Stop Time** – This is the time that the recording will stop. It's based on a 24-hour format.



A failure on the Ethernet network will not interrupt data recording.

#### 4.4.6.2 Status

This page describes the Recording and SD flash card status.

All the fields on this page are read-only.

Status

Address <http://192.168.1.200>

Readings Chart Web Link **Setup**

Start Recording | **Status** | Data Retrieval | Format SD Card

Overview  
Network  
Configuration  
Management  
Security  
**Recording**  
System  
Diagnostics  
Log Out

Current Date: **2099/01/01** Current Time: **00:00:00**

**Recording Status**

Recording **OFF**

StartDate (yyyy/mm/dd)	StartTime (hh:mm:ss)(24 hours)
StopDate (yyyy/mm/dd)	StopTime (hh:mm:ss)(24 hours)
Category	Type
Interval	Title

**SD Card Status**

SD Card Detected	YES
SD Card Write Protected	NO
Total Flash Size	1925456(KB)
Available Flash Size	1925452(KB)

**Battery Status**

Check Battery

Uptime 0 days,00:00:00 hh:mm:ss

Figure 4.23 Recording Menu: Status

### 4.4.6.3 Data Retrieval

This page can be used to retrieve the recorded data from the SD flash card and save it into an ASCII file.

Using the *Retrieve EndDate* field select the date (year, month, and day) that is the end date for the retrieved data.

Then use *Retrieve Period* field to identify the duration of the retrieved data; selections are: 1 Day, 1 Week, 1 Month and 1 Year.

**Note** The year, month and day dates are taken from your computer.

Now, you can press on the *Start Data Retrieval* button to log the data into a file.

The file is a text document with extension **.csv**. It can be opened in MS Excel, MS Wordpad, Notepad or any software package that can read text files.

The fields are separated by a comma ( , ) see Figure **Figure 4.40** for a sample text file.

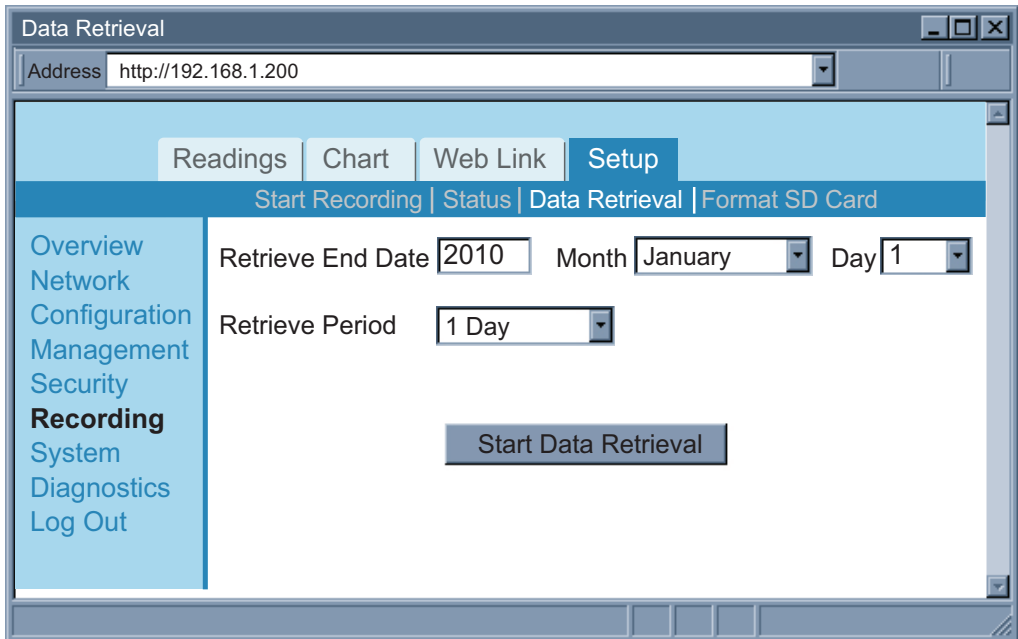

**Figure 4.24 Recording Menu: Data Retrieval**

**Note** Refer to **Section 4.10.1** for steps that may help you to open the data file in an ASCII or Excel application.

**Note** The data recorded on the SD card can be read on a PC or MAC using a USB or any standard card reader. The file format is text and is easily imported to spread sheets and other programs. For details see **Section 4.10**.

#### 4.4.6.4 Format SD Card

Clicking on Format SD Card button will start formatting the flash card inside the iServer. Formatting the SD card will erase all data on the card. Allow up to 2 minutes for format to be completed which then it will display “SD Card Formatted”.

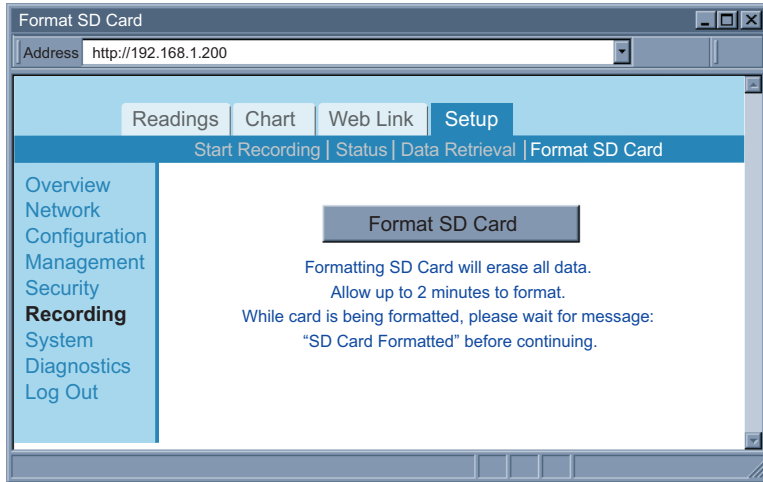

Figure 4.25 Recording Menu: Format SD Card

#### 4.4.7 System

This menu provides various options to reboot, restore defaults, upgrade firmware and download/upload configuration for the iServer. Fields are described below.

##### 4.4.7.1 Reboot

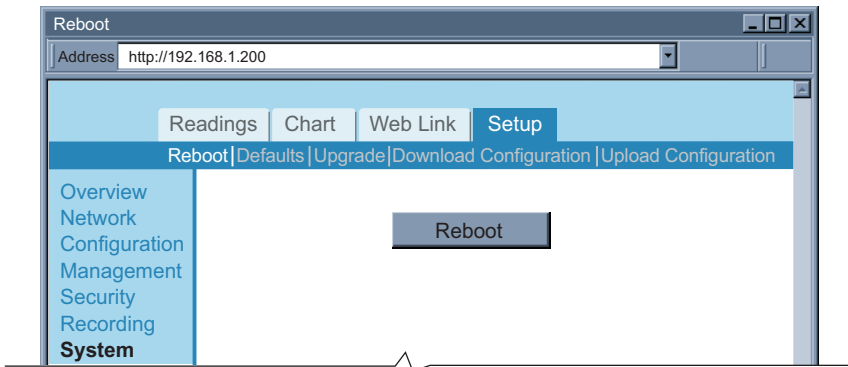

Figure 4.26 System: Reboot

**Reboot** – This option resets the power on the iServer.

If the iServer is recording data the reboot option will stop the recording.

It will also set the real date/time back to default unless the Network Time Server option from Configuration page, is enabled.

#### 4.4.7.2 Defaults

Clicking on this button will put the iServer back to its default settings.

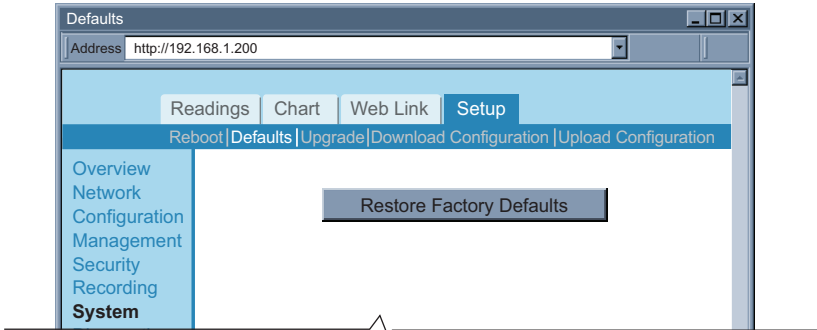

Figure 4.27 System: Defaults

#### 4.4.7.3 Upgrade

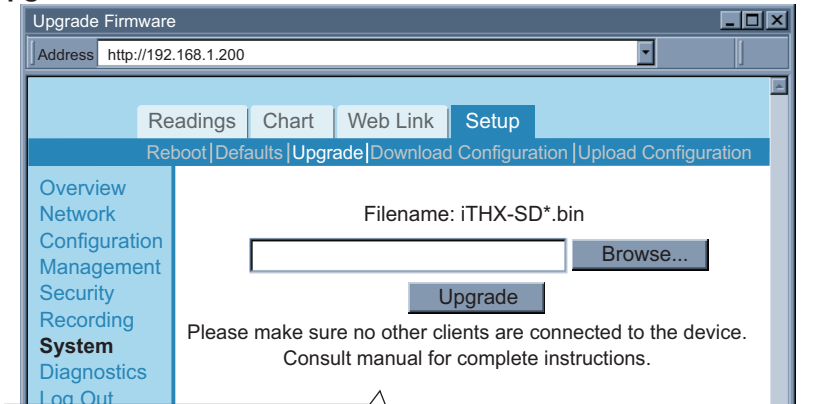

Figure 4.28 System: Upgrade

**Upgrade** – This option loads a new firmware into the iServer over the network. The firmware is a binary file with **.bin** extension. This file must be kept on the same PC from which the iServer is accessed.

If you have an iServer with a firmware version previous to 1.09.0, it is **mandatory** to set the iServer to default settings after a firmware upgrade to any version, after 1.09.0.

Once the firmware upload is completed the iServer will power reset itself. This typically takes about 30 seconds.

**Note**

When doing firmware upgrade on the iServer, there should be **NO** other on-going or new Web server (HTTP) connections made to the device; otherwise, the iServer will not upgrade the firmware. You can do either of the following to prevent this from happening:

1. Connect the iServer directly to the PC using a straight or crossed Ethernet cable. This will also help to have a faster firmware upload.
2. From the “Network” menu, change the Web Server Port, for example, to 500 (default is 80), save the change, and reset the power on your iServer. The next time you will access the iServer’s Web server, you must type **http://192.168.1.200:500** where **192.168.1.200** is the IP address of the iServer and **500** is the new Web server port (HTTP port).

### 4.4.7.3 Upgrade (continued)

Either one of the above options will make you the only user on that iServer.

Set the iServer to default settings after the firmware is upgraded.

See **Section 4.4.7.2** on how to set the iServer to default settings.

Applying default settings will change the iServer's settings to factory defaults.

If those settings are important to you and you do not want to reconfigure the iServer, you will need to do the following steps.

From the "System" menu:

- 1) "Download" the iServer's configuration settings, **Section 4.4.7.4**.
- 2) "Upgrade" the iServer with the new firmware, **Section 4.4.7.3**.
- 3) Set the iServer to "Default" settings. The iServer's IP address is now 192.168.1.200.
- 4) "Upload" the same configuration you obtained from step 1 onto the iServer, **Section 4.4.7.5**.

**Note**

After you have successfully upgraded your device, you can verify the firmware version number on the "Overview" page (see **Section 4.4.1**).

### 4.4.7.4 Download Configuration

Clicking on this button will download the configuration file that contains all the settings stored in the iServer and use it as a reference.

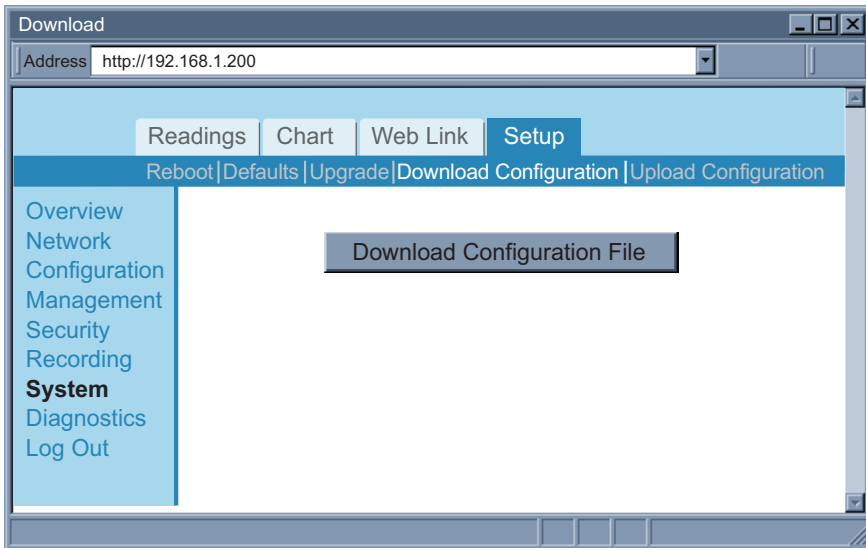

**Figure 4.29 System: Download Configuration**

### 4.4.7.5 Upload Configuration

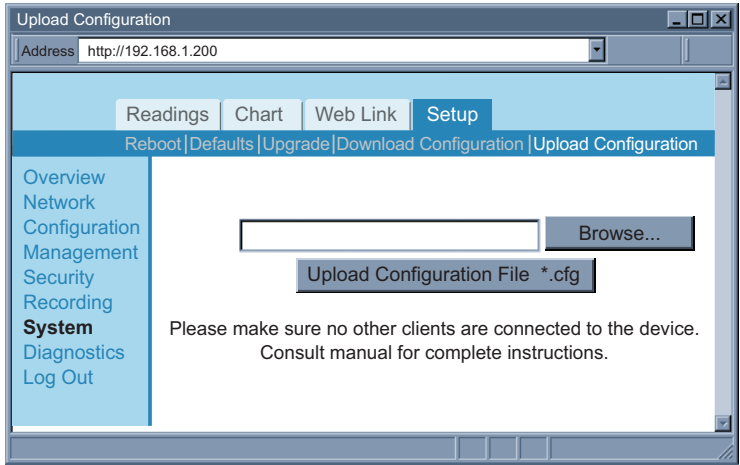

**Figure 4.30 System: Upload Configuration**

**Upload Configuration** – Using this option to upload the configuration file into the iServer. It is recommended to *download* and store a working copy of this configuration file in case the device is configured improperly.



You can set the iServer to its *default* settings and *upload* the configuration file back into the iServer.

### 4.4.8 Diagnostics

This page provides the number of Ethernet packets received or transmitted. Pressing the Reset Counter button will set the counts to zero.

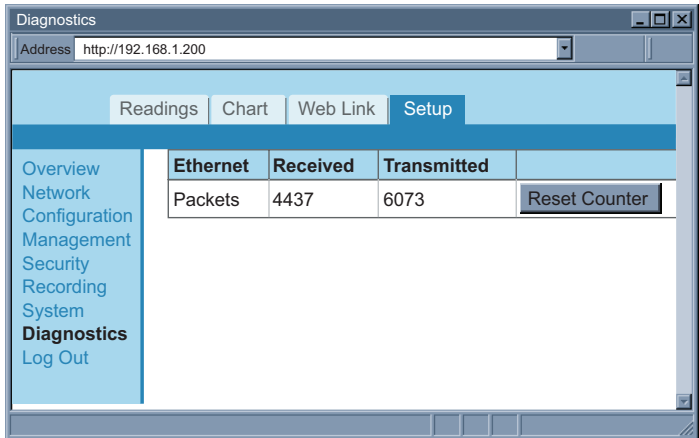

**Figure 4.31 Diagnostics**

### 4.4.9 Log Out

Once you click on Log Out, you will be logged out, and taken back to the Welcome page.

## 4.5 Readings

This page displays temperature, humidity, dew point, and the status of the alarm relays and recording.

It can be displayed either as an HTML page or a Java applet.

### 4.5.1 HTML

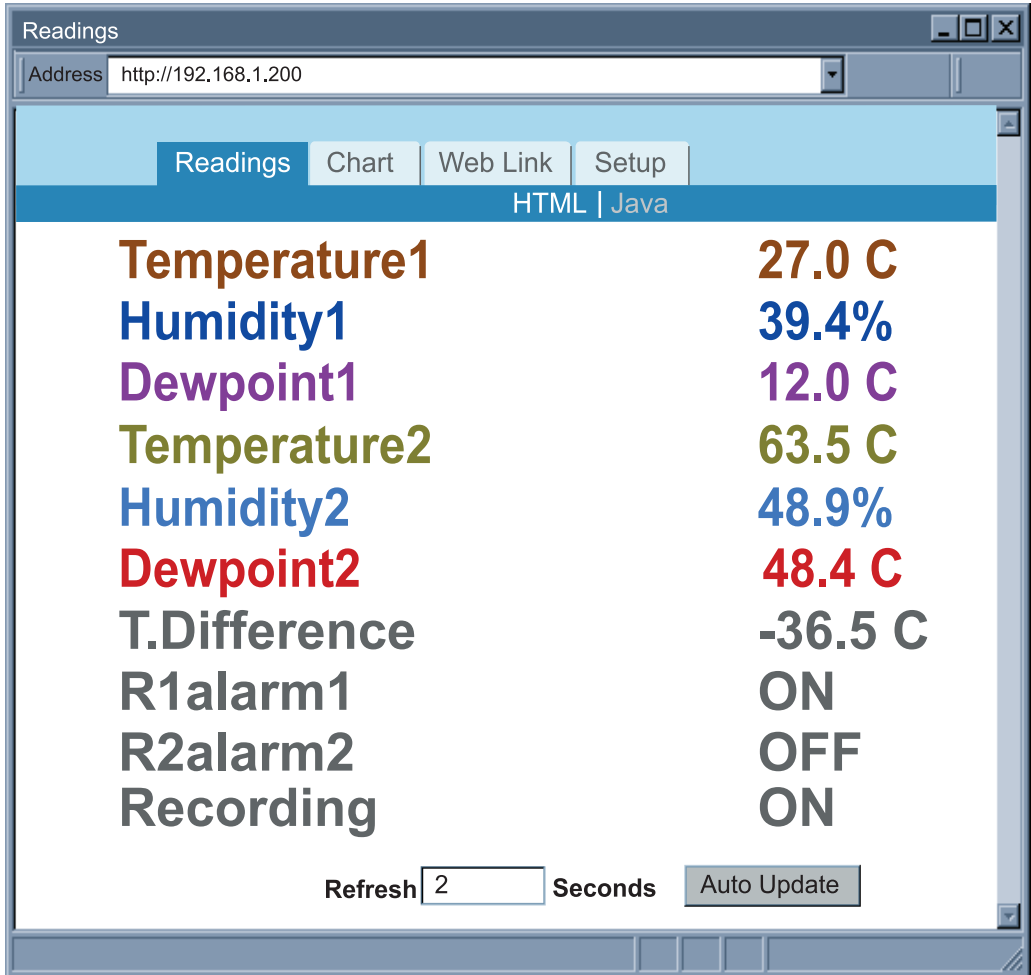
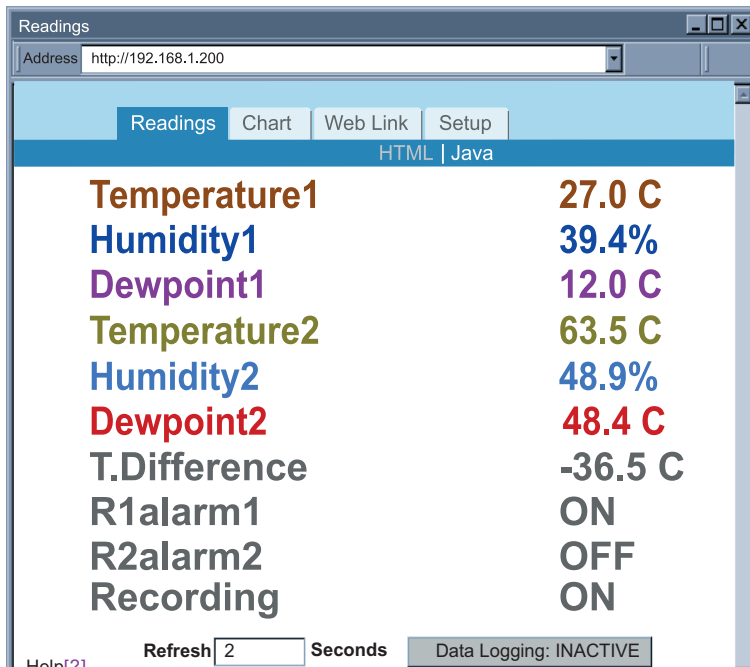

Figure 4.32 Readings: HTML - Shown with Probe 1 and 2 Enabled

**Refresh** – Adding a time value in seconds will automatically update the HTML page with fresh readings.

## 4.5.2 Java

If Java option is chosen installation of Java Runtime is required (refer to **Appendix G**).



**Figure 4.33 Readings: Java - shown with Probe 1 enabled**

**Data Logging** – This option will require the Java Policy file to be setup.

Press on **Help[?]** for details.

An alternate way to set up the Java Policy can be found in **Appendix G**.

Once the Java Policy file is completed, click on *Data Logging* button to log the data displayed on this page into a file. The file is in comma separated values (.csv) format, which can be opened in Excel or as ASCII. The fields are separated by a comma ( , ).

When the button is *ACTIVE* it means that the data is currently being logged into a file. The value in seconds in the Refresh box determines how often the data is being logged. The default is 2 seconds.

**Note** If you want to access the “Chart” and/or the “Readings” applet from outside your local network on which the iServer is connected, you must allow ports 1001 (Readings) and 2003 (Chart) on your Router.

**Note** If a blank screen appears without any “java application running” or image of a “Java logo”, please verify you have the latest Java Runtime Environment installed and configured according to the instructions (refer to **Appendix G**). If you do not have Java Runtime Environment installed, you may download it from our website (in the software section) or contact the Customer Service Department nearest you.

“Java and the Java Coffee Cup Logo are trademarks or registered trademarks of Sun Microsystems, Inc. in the U.S. and other countries.”

## 4.6 Chart

This page charts the temperature, humidity, and dew point in real-time across the full span (-40 to 124°C, and 0 to 100% RH) or within any narrow range (such as 20 to 30°C). The time-base can display one minute, one hour, one day, one week, one month or one year.

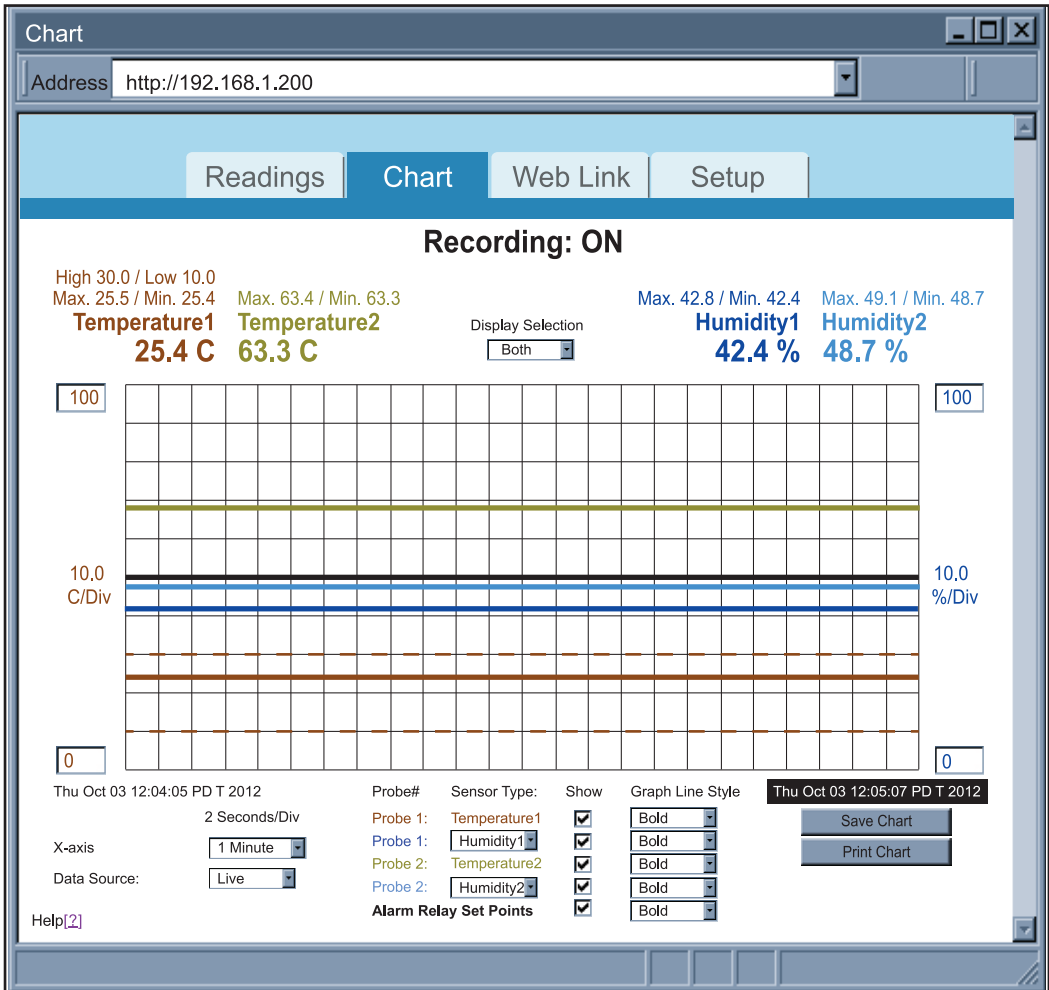

**Figure 4.34 Adjustable Chart**

**Note**

If a blank screen appears without any “java application running” or image of a “Java logo”, please verify you have the latest Java Runtime Environment installed and configured according to the instructions (refer to **Appendix G**). If you do not have Java Runtime Environment, you may download it from our website (in the software section) or contact the Customer Service Department nearest you.

**High / Low** – If Alarm Relays are enabled (in the Configuration menu), the set point values for *High* and *Low* alarms will be listed and graphed on the chart.

**Max. / Min.** – This shows the maximum and minimum values for Temperature and Humidity (or Dewpoint) indicated on the Y-axis.

## 4.6 Chart (continued)

**Display Selection** – The options are *Both Probes*, *Probe 1*, and *Probe 2*

**X-axis** – This indicates the time, options includes *one minute*, *one hour*, *one day*, *one week*, *one month* or *one year*.

**Y-axis** – The left Y-axis is dedicated to temperature. Either *humidity* or *dewpoint* can be selected for the right Y-axis.

**Data Source** – The options are *Live* and *Recorded*.

If *Live* is selected the real-time data will be charted for the time indicated on the X-axis.

If *Recorded* is selected the stored data on the SD card will be charted for the time indicated on the X-axis.

**Alarm Relay Set Points** – This option will *hide* or chart (*normal*) the set point values. The *bold* option will thicken the displayed set point lines.

**Note** If Alarm Relays are *disabled* (in the Configuration menu) the set points for *High* and *Low* alarms will not be graphed or displayed on the chart.

**Sensor Type** – Choose *Humidity* or *Dewpoint*.

**Show** – To select which probes are charted.

**Graph Line Style** – Choose between *Normal* and *Bold*.

**Save Chart** – Save the current graph in PNG (Portable Network Graphics) format. The filename has extension **.png**. This option will require the Java Policy file to be setup.

Press on **Help[?]** for details. An alternate way to set up the Java Policy can be found in **Appendix G**.

**Print Chart** – The displayed chart will be printed once the button is clicked.

**Note** If you want to access the “Chart” and/or the “Readings” applet from outside your local network on which the iServer is connected, you must allow ports 1001 (Readings) and 2003 (Chart) on your Router.

## 4.7 Web Link

This page is configured from the Network menu under IP configuration.

Refer to **Section 4.4.2.1**.

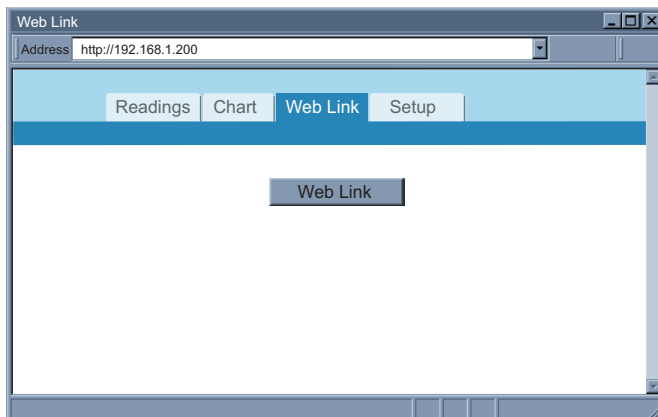

**Figure 4.35 Web Link**

## 4.8 Telnet Setup

With a telnet program, you can connect to the iServer using its IP address and TCP Port 2000. In *Continuous* mode (refer to Configuration:Sensors page **Section 4.4.3.2**), the telnet session will receive continuous data (temperature and humidity) from the iServer. In *Command* mode, a command can be sent to query the iServer.

Refer to **Section 4.9.1** for list of commands.

### 4.8.1 Telnet Connection

Telnet stands for Telecommunications Network, it is a protocol that provides a way for users to connect to a node with a valid IP address anywhere on an Ethernet network or the Internet . You can open a Telnet session using a terminal emulation programs like Tera Term (downloadable from the internet), which is a free software for Windows.

You can initiate a telnet connection by typing the IP address of the iServer, and Port 2002 for logging into the iServer's telnet consol port (see **Figure 4.36**). By telneting to Port 2000, you will be able to access temperature, humidity, and dew point readings.

**Note** The default password for Telnet Login is **00000000** and can be changed if desired.

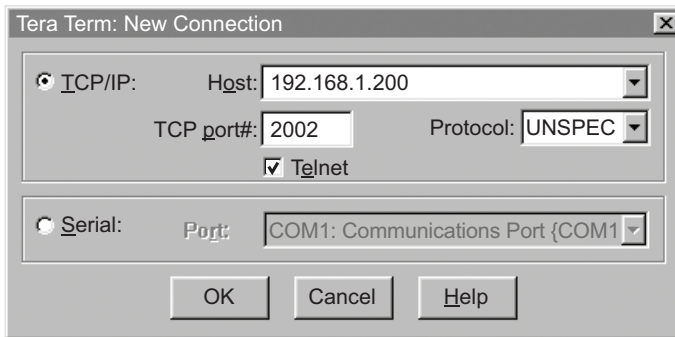

**Figure 4.36 Tera Term Telnet Connection Screen**

Once the connection is established you will be prompted for an Administrator Password (default is 00000000). Telnet console port (2002) allows users to configure some parameters within the iServer. **Figure 4.38** shows the parameters that can be changed.

After connecting to the iServer, you can use the following commands to read, modify, and get help.

- p** displays the current settings (**Figure 4.37**)
- ?** displays all the available options as well as an example on how to enter a command (**Figure 4.38**)
- s** set a new configuration (see the example in **Figure 4.38**), sending the command **c** is required to permanently store the new settings
- RESET** restart the iServer
- FACTORY** set the iServer to it's factory default, the RESET command is required after the FACTORY command
- c** permanently store the new settings
- q** quit the telnet session

## 4.8.1 Telnet Connection (continued)

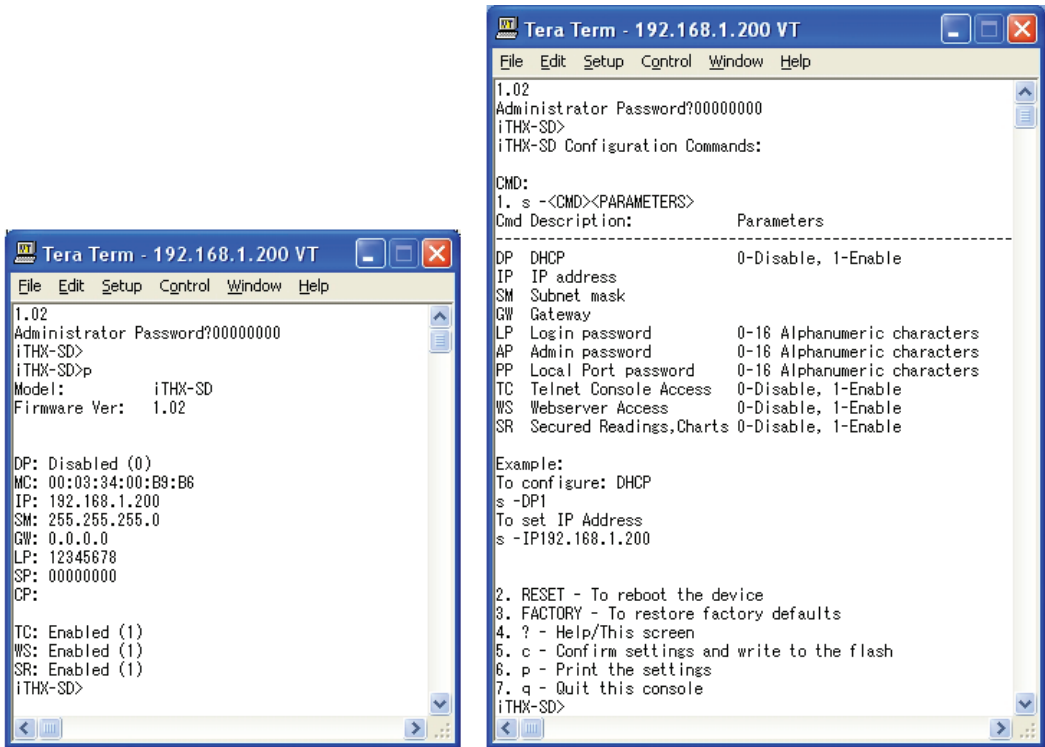

Figure 4.37Figure 4.38

Telnet to port 2002 – p command

Telnet to port 2002 – ? command

## 4.9 HTTPget Program

The HTTPget software is used to send a single HTTP or TCP request to an iServer product. In contrast, the telnet or Hyperterminal programs allow a continuous connection with multiple requests to be sent to the iServer product.

Generally HTTPget is used for simply programming an IP address to the iServer or for quickly obtaining a reading of from a device.

The iServer product must be configured from the configuration web page so that the “Server Type” value is set to “Command”, refer to **Section 4.4.3.2**.

## 4.9.1 HTTPget using Port 2000

You can setup and read the information from the iServer by using the HTTPget program. The following program can be used to read data from the iServer by using TCP port **2000**. The command string is sent to this TCP port, then the response can be read back from the same socket.

The HTTPget.exe file is used to setup and read information from the iServer. This file can be downloaded from the website listed on the cover of this manual (software section).

Notes on using **HTTPget** :

The HTTPget.exe program should be installed to the windows directory (usually c:\winnt or c:\windows)

1. Open up a command window (or have a DOS window)
  - a) Click on start menu
  - b) Click on "Run"
  - c) In the dialog box that appears, type "cmd" or "command" and click on "OK" button.
  - d) A command window should now appear.
2. If you now type "httpget" and press the "enter" key, the program options should be displayed.
3. Next run HTTPget with the options displayed below

```
httpget -r -S "*"SRTC\r" 192.168.1.200:2000
```

**where:**

**-r -S** are parameters needed for the command string

**\*SRTC** is the command:

**\r** is the carriage return termination character

**192.168.1.200** is an IP address

**2000** is a socket port number

**Response:**

076.6 (in Deg.F format)

<b>*SRT/*SRTC</b>	Get Temperature Reading in Celsius from Probe 1
<b>*SRT2/*SRTC2</b>	Get Temperature Reading in Celsius from Probe 2
<b>*SRT3/*SRTC3</b>	Get Temperature Reading in Celsius from Probe 1 and 2; separated by a semi-colon
<b>*SRTF</b>	Get Temperature Reading in Fahrenheit from Probe 1
<b>*SRTF2</b>	Get Temperature Reading in Fahrenheit from Probe 2
<b>*SRTF3</b>	Get Temperature Reading in Fahrenheit from Probe 1 and 2; separated by a semi-colon
<b>*SRH</b>	Get Humidity (%) Reading from Probe 1
<b>*SRH2</b>	Get Humidity (%) Reading from Probe 2
<b>*SRH3</b>	Get Humidity (%) Reading from Probe 1 and 2; separated by a semi-colon
<b>*SRD/*SRDC</b>	Get Dewpoint Reading in Celsius from Probe 1
<b>*SRD2/*SRDC2</b>	Get Dewpoint Reading in Celsius from Probe 2
<b>*SRD3/*SRDC3</b>	Get Dewpoint Reading in Celsius from Probe 1 and 2; separated by a semi-colon

#### 4.9.1 HTTPget using Port 2000 (continued)

*SRDF	Get Dewpoint Reading in Fahrenheit from Probe 1
*SRTD2	Get Dewpoint Reading in Fahrenheit from Probe 1
*SRDF3	Get Dewpoint Reading in Fahrenheit from Probe 1 and 2; separated by a semi-colon
*SRB/*SRBC	Get Temperature and Humidity Reading in Celsius from Probe 1; separated by a semi-colon
*SRB2/*SRBC2	Get Temperature and Humidity Reading in Celsius from Probe 2; separated by a semi-colon
*SRB3/*SRBC3	Get Temperature and Humidity Reading in Celsius from Probe 1 and 2; separated by a semi-colon
*SRBF	Get Temperature and Humidity Reading in Fahrenheit from Probe 1; separated by a semi-colon
*SRBF2	Get Temperature and Humidity Reading in Fahrenheit from Probe 2; separated by a semi-colon
*SRBF3	Get Temperature and Humidity Reading in Fahrenheit from Probe 1 and 2; separated by a semi-colon
*SRYS	Indicate AC or DC power and battery status
*SRYRST	Reset Power on
*SR_XD1	Disable alarm condition check for relay 1
*SR_XD2	Disable alarm condition check for relay 2
*SR_XC2	Reset relay 2 latch condition
*SR_XC1	Reset relay 1 latch condition
*SR_XC2	Reset relay 2 latch condition
*SR_XE1	Re-enable alarm condition check for relay 1 (must be executed after *SR_XD1)
*SR_XE2	Re-enable alarm condition check for relay 2 (must be executed after *SR_XD2)
*SR_XP1	Close relay 1 for < 200 mSec
*SR_XP2	Close relay 2 for < 200 mSec
*SR_XH1	Close relay 1
*SR_XH2	Close relay 2
*SR_XL1	Open relay 1
*SR_XL2	Open relay 2
*SR_XR1	Read current state of relay 1
*SR_XR2	Read current state of relay 2

#### Commands developed specifically for DASyLab/LabView

*SRAC	Get All Readings in below format in Celsius
*SRAF	Get All Readings in below format in Fahrenheit

##### Format:

T1[+/-]###.#H1[+/-]###.#D1[+/-]###.#T2[+/-]###.#H2[+/-]###.#D2[+/-]###.#:[EndCharacter]

*SRACS	Get All Readings in below format in Celsius
*SRAFS	Get All Readings in below format in Fahrenheit

##### Format:

[+/-]###.# [+/-]###.# [+/-]###.# [+/-]###.# [+/-]###.#:[EndCharacter]

## 4.10 Flash Card Reader

The data recorded on the SD card can be read on a PC or MAC with a USB or any standard card reader.

The format is a simple “.csv” text file that is easily imported in MS Excel or MS WordPad or any software package that can read text files (see **Figure 4.40**).

The entire recording session is saved into a file kept in the root directory.

The name of this file is **S** followed by the date the recording was started, so for example: **S20100401.txt** is April 1st, 2010.

The same recording data is also saved as daily files located in a series of month and year directories in which the recording took place (see **Figure 4.39**).

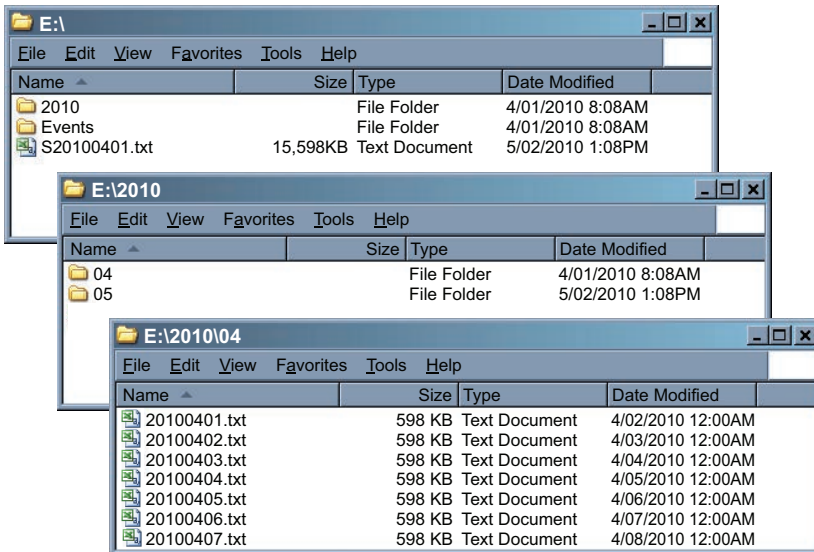

**Figure 4.39 Recorded Data File Directory**

```
#2010/04/02;09:00:00;23.3C;35.6%;D6.7C;  
#2010/04/02;09:00:10;23.3C;35.6%;D6.7C;  
#2010/04/02;09:00:20;23.3C;35.6%;D6.7C;  
#2010/04/02;09:00:30;23.3C;35.7%;D6.7C;  
#2010/04/02;09:00:40;23.3C;35.7%;D6.7C;
```

**Figure 4.40**  
**Example of data recorded**  
**on the SD card**

#### 4.10.1 Opening Older iTHX-SD .txt Data Files

1. Right-click on the data file and select Open with Wordpad. This will display the ASCII data in WordPad.
2. From the Edit menu select the Replace option to replace all the ; (semicolons) with , (commas).
3. From the File menu select Save As and save the file with an extension **.csv** (Comma Separated Value).
4. This **.csv** file can now be opened in Excel with the correct format.

#### Alternatively, you can do the following--

1. Open Excel. Go to File, Open, select Files of Type: Choose Text files (\*.prn, \*.txt, \*.csv), and then select the data file you wish to open.
2. A Text Import Wizard should pop-up.  
Select Delimited type of file, then Next.  
Click on **semicolon** as the Delimiter type, then Next.  
The screen should show how the file is being divided into columns, click on Finish.
3. From the File menu select Save As and save the file with an extension **.csv**.  
The next time you open this file it will open in Excel automatically.

**Tip**

You may remove the letters C or F and D from the recorded values (using the Replace option of Excel or Wordpad). This will enable you to create charts of the data.

## 4.11 iLog Software

This is an Excel application software that can log temperature, humidity and dewpoint from the iServer over the local network (Ethernet) or the internet.

- a) Download the iLog software from the website listed in this manual.
- b) Install iLog software on a networked PC. This software is compatible with Windows 95, 98, NT, 2000, XP, Windows Vista and Windows 7 (32 and 64-bit).
- c) If you have Excel 2007 or higher, when installing iLog choose “Custom” installation option and on the next window check the box for “Excel 2007 Apps” and continue the installation to the end.
- d) For complete information of how to use the iLog software, click on the HELP button.
- e) There is a list of Error Messages in **Appendix F**.
- f) For single probe units use iLog -- 1.9.4;  
for dual probe units use iLog - iTHX-W Dual Probe

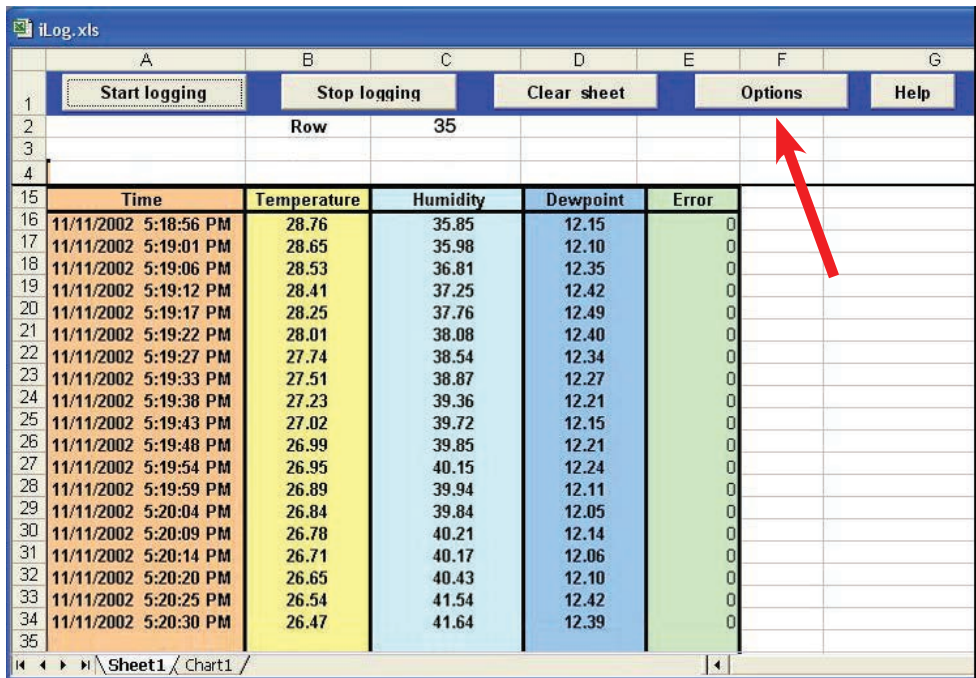

	A	B	C	D	E	F	G
1	Start logging	Stop logging	Clear sheet	Options	Help		
2		Row	35				
3							
4							
15	Time	Temperature	Humidity	Dewpoint	Error		
16	11/11/2002 5:18:56 PM	28.76	35.85	12.15	0		
17	11/11/2002 5:19:01 PM	28.65	35.98	12.10	0		
18	11/11/2002 5:19:06 PM	28.53	36.81	12.35	0		
19	11/11/2002 5:19:12 PM	28.41	37.25	12.42	0		
20	11/11/2002 5:19:17 PM	28.25	37.76	12.49	0		
21	11/11/2002 5:19:22 PM	28.01	38.08	12.40	0		
22	11/11/2002 5:19:27 PM	27.74	38.54	12.34	0		
23	11/11/2002 5:19:33 PM	27.51	38.87	12.27	0		
24	11/11/2002 5:19:38 PM	27.23	39.36	12.21	0		
25	11/11/2002 5:19:43 PM	27.02	39.72	12.15	0		
26	11/11/2002 5:19:48 PM	26.99	39.85	12.21	0		
27	11/11/2002 5:19:54 PM	26.95	40.15	12.24	0		
28	11/11/2002 5:19:59 PM	26.89	39.94	12.11	0		
29	11/11/2002 5:20:04 PM	26.84	39.84	12.05	0		
30	11/11/2002 5:20:09 PM	26.78	40.21	12.14	0		
31	11/11/2002 5:20:14 PM	26.71	40.17	12.06	0		
32	11/11/2002 5:20:20 PM	26.65	40.43	12.10	0		
33	11/11/2002 5:20:25 PM	26.54	41.54	12.42	0		
34	11/11/2002 5:20:30 PM	26.47	41.64	12.39	0		
35							

Figure 4.41 iLog Software Logging Data

Note

The Options button will let you select the product model.  
Choose **iTHX-SD** from the Model Selection pull-down menu (from General tab).

## iLog Software (continued)

**Table 4.1 iLog Excel Applications**

The iLog application actually consists of several Excel files, though most supported devices can be accessed by the main iLog program. The main program is listed as “iLog”, plus a version number, under the Start Menu program links (those links available by clicking the Start button on the Windows taskbar).

In the following table, the iLog File column shows how many sensors are logged by the main iLog file. If more than 3 sensors are available, then the Alternate column shows how many sensors the device can support. Devices with more than 3 sensors will have their own Excel file. For these files, click on the model device found in the Start Menu.

<b>Networked Product</b>	<b>iLog File</b>	<b>Alternate</b>
iTHX-W, iTHX-2	3 column	
iTHX-M, <b>iTHX-SD</b>	3 column	
<b>iTHX-W Dual Probe</b>	1st probe / 3 column	6 column
iSE-TC, iSD-TC	3 column	5 column
iSE-TH, iSD-TH	3 column	5 column
iBTHX-W, iBTHX-D	3 column	4 column
iBTX-W/-D, iBTX-M, iBTX-SD	2 column	
iPTX-W	2 column	
ITCX	3 column	
iTH Controller	3 column	
iVI	3 column	4 column
iSeries	1 column	
iDRX/iDRN	1 column	
INF-B	1 column	

### **Wireless Devices**

The “Auto” column shows number of columns per remote device that are possibly displayed.

The Full column shows number of columns allocated per device for the “Full” spreadsheet, which will be able to display all data for all active devices.

<b>Networked Product</b>	<b>Auto</b>	<b>Full</b>
zSeries Receiver and Remotes	1 to 4 column / device	4 column / 32 device
wiSeries with zED Remotes	1 to 2 column / device	2 column / 32 device
UWTC REC-3 and Remotes	1 or 2 column / device	2 column / 32 device
wiSeries with UWTC Remotes	1 to 2 column / device	2 column / 32 device

The active wireless devices, when shown in the Excel application, will be shown with the device number and the units returned.

## PART 5 SPECIFICATIONS

### SENSOR SPECIFICATIONS

#### Relative Humidity (RH)

Accuracy/Range:	±2% for 10 to 90%; ±3% for 5 to 10% and 90 to 95% ±4% for 0 to 5% and 95 to 100% Refer to chart in <b>Appendix H</b>
Hysteresis:	±1% RH
Non-linearity:	±3%
Response Time:	8 seconds, tau 63% (time for reaching 63% of a step function, valid at 25C and 1m/s airflow)
Repeatability:	±0.1%
Resolution:	0.1%, 12bit

**NOTE:** Reconditioning of the probe may be necessary if the probe is stored for a period of time in a harsh environment (temperatures below 0°C or above 70°C or exposure to chemical vapors, condensation, etc). To recondition the probe refer to **Appendix H.4**

#### Temperature (T)

##### Accuracy/Range\*:

##### Wand Probe:

±0.5°C for 5° to 45°C (±1°F for 41° to 113°F);  
Up to ±1°C for 0° to 5°C and 45° to 70°C  
Up to ±2°F for 32° to 41°F and 113° to 158°F)  
Refer to chart in **Appendix H**

##### Industrial Probe:

±0.5°C for 5° to 45°C ( ±1°F for 41 to 113°F);  
Up to ±1.5°C for -40° to 5°C and 45° to 124°C  
Up to ±2.7°F for -40° to 41°F and 113° to 255°F)  
Refer to chart in **Appendix H**

##### Response Time:

\*Note: extended temperature range is for Industrial Probe only, the iServer's operating temperature is 0 to 60°C  
5 to 30 seconds, tau 63% (response time depends on heat capacity of and thermal resistance to sensor substrate)

##### Repeatability:

±0.1°C

##### Resolution:

0.1°C, 14 bit

### PROBE SPECIFICATIONS

##### Wand Probe:

198 mm long x 19 mm diameter (7.8" x 0.75")  
Cable with DB9 connector: 152 mm long (6")  
Cable operating temperature: 0 to 80°C (32 to 176°F)

##### Industrial Probe:

137mm *or* 51mm long x 16mm diameter (5" *or* 2" x 0.63")  
Cable with DB9 connector: 3m *or* 0.9m long (10' *or* 3')  
Cable operating temperature: -40 to 125°C (-40 to 257°F)

## **iSERVER SPECIFICATIONS**

### **Interfaces**

<b>Ethernet (RJ45):</b>	Fixed or auto-negotiating 10/100Base-T; Auto MDI/MDIX
<b>Sensor:</b>	Digital 4-wire (DB-9)
<b>Supported Protocols:</b>	TCP, UDP, SNMP, SMTP, SNTP, ARP, ICMP, DNS, DHCP, HTTP, and Telnet
<b>LED Indicators:</b>	100 BASE-T, Network Link and Activity, DHCP, Recording
<b>LCD Display:</b>	16 digits, 6mm (0.23")
<b>Memory Data Flash Card:</b>	2 GB SD Flash Card for 8 months of data storage at 1 second recording intervals, or 7 years at 10 seconds
<b>Relay Outputs:</b>	Two relays 1.5A @ 30Vdc
<b>Management:</b>	Device configuration and monitoring through embedded WEB server
<b>Embedded WEB Server:</b>	Serves WEB pages containing real-time data and live updated charts within definable time intervals.

### **POWER**

<b>Power Input:</b>	9 to 12 Vdc
<b>Consumption:</b>	3.5 W.
<b>Safety Qualified ac Power Adapter (included)</b>	<b>Nominal Output:</b> 9 Vdc @ 0.5 A <b>Input:</b> 100 to 240 Vac, 50/60Hz
<b>Back-up Battery:</b>	9 Vdc, alkaline. 30 hours at 10 second recording intervals, or 60 hours at 1 minute intervals

### **ENVIRONMENTAL**

#### **Operating Temperatures**

<b>iServer Unit:</b>	0 to 60°C (32 to 140°F)
<b>Battery:</b>	-18 to 55°C (-0.4 to 131°F)
<b>ac Power Adapter:</b>	0 to 40°C (32 to 104°F)
<b>Wand Cable:</b>	0 to 80°C (32 to 176°F)
<b>Industrial Cable:</b>	-40 to 125°C (-40 to 257°F)
<b>Storage Temperature:</b>	-40 to 85°C (-40 to 185°F)
<b>Material:</b>	Steel metal case with wall mount bracket
<b>iServer Housing Dimensions:</b>	36.6H x 62W x 90D mm (1.44 x 2.93 x 3.56 in)
<b>Weight:</b>	389 g (0.86 lbs.), including battery

### **GENERAL**

<b>Agency Approvals:</b>	FCC-B, CE
<b>Software:</b>	Compatible with Windows operating systems Firmware upgrade from Ethernet <b>OPC Server</b> <b>iConnect:</b> Configuration software for the Ethernet interface <b>iLog:</b> Macro for automatic data logging in MS Excel

User of this manual should be familiar with following definitions:

**ARP (Address Resolution Protocol)** is a protocol for mapping an Internet Protocol address (IP address) to a physical machine address that is recognized in the local network. For example, the IP address in use today is an address that is 32-bits long. In an Ethernet local area network, however, addresses for attached devices are 48-bits long. (The physical machine address is also known as a Media Access Control or MAC address.) A table, usually called the ARP cache, is used to maintain a correlation between each MAC address and its corresponding IP address. ARP provides the protocol rules for making this correlation and providing address conversion in both directions.

**Ethernet** is a network protocol defined by the IEEE 802.3 standard. Ethernet-based networks use MAC Address rather than IP Address to exchange data between computers. By using ARP and adding TCP/IP support, Ethernet devices may be connected as part of the Internet. An Ethernet LAN typically uses coaxial cable or special grades of twisted pair wires. The most commonly installed Ethernet systems are called 10BASE-T and provide transmission speeds up to 10 Mbps. Devices are connected to the cable and compete for access using a Carrier Sense Multiple Access with Collision Detection (CSMA/CD) protocol.

**IP (Internet Protocol)** is the method or protocol by which data is sent from one computer to another on the Internet.

**IP address (Internet Protocol address)** is a 32-bit number that identifies each sender or receiver of information that is sent in packets across the Internet.

**IP Netmask** is a 32-bit pattern of bits used to determine which part of the IP address is the network portion and which part is the host portion.

**MAC (Media Access Control) Address** is your computer's unique hardware number. When you're connected to the Internet from your computer, a correspondence table relates your IP address to your computer's physical (MAC) address on the LAN.

**Ping** is a utility that tests the network connectivity. It is used to determine if the host is capable of exchanging information with another host.

**Port number/Socket number** is a way to identify a specific process to which an Internet or other network message is to be forwarded when it arrives at a server. It is a predefined address that serves as a route from the application to the Transport layer or from the Transport layer to the application of the TCP/IP system.

**Sockets** are a method for communication between a client program and a server program in a network and defined as "the endpoint in a connection." Information transferred across the Internet primarily occurs between sockets.

**SMTP** Simple Mail Transfer Protocol is an Internet standard for electronic mail (email) transfer across the Internet. SMTP clients usually use SMTP to send email messages by specifying the SMTP server. The email server uses SMTP to both send and receive email messages.

**SNMP** Simple Network Management Protocol is a network monitoring protocol to monitor devices connected to an Ethernet Network.

**TCP/IP (Transmission Control Protocol/Internet Protocol)** is the basic communication language or protocol of the Internet. When you are set up with direct access to the Internet, your computer is provided with a copy of the TCP/IP program just as every other computer that you may send messages to or get information from also has a copy of TCP/IP. TCP/IP often is used as a general term to indicate generic access to the Internet.

**UDP/IP (User Datagram Protocol/Internet Protocol)** is the TCP/IP standard protocol that allows an application program on one machine to send a datagram to an application program on another. The UDP can be either in Broadcast or Directed form. The Broadcast UDP transmits data to every node on the same network. The Directed UDP transmits data to one node only.

## Appendix B

## IP Address

An IP address is a unique 32-bit address assigned to a computer and includes:

- A network ID number identifying a network.
- A host ID number identifying a computer on the network.

All IP addresses have been divided into three smaller groups (classes) A, B and C

- **Class A** addresses have 8-bits of network ID and 24-bits of host ID. They can support a large number of hosts, approximately  $2^{24} = 16,777,216$  computers per network.

The IP addresses range in binary from 00000001.xxxxxxxx.xxxxxxxx.xxxxxxxx  
to 01111111.xxxxxxxx.xxxxxxxx.xxxxxxxx

The IP addresses range in decimal from 1.x.x.x to 127.x.x.x

Class A network ID's support a very large number of hosts.

- **Class B** addresses have 16-bits of network ID and 16-bits of host ID. They can support approximately  $2^{16} = 65,536$  computers per network.

The IP addresses range in binary from 10000000 00000000.xxxxxxxx.xxxxxxxx  
to 10111111 11111111.xxxxxxxx.xxxxxxxx

The IP addresses range in decimal from 128.0.x.x TO 191.255.xxx.xxx

Class B network ID's support a medium number of hosts.

- **Class C** addresses have 24-bits of network ID and 8-bits of host ID. They can support approximately  $2^8 = 256$  computers per network.

The IP addresses range in binary from 11000000.00000000.00000000.xxxxxxxx  
to 11011111.11111111.11111111.xxxxxxxx

The IP addresses range in decimal from 192.0.0.xxx to 223.255.255.xxx

Class C network ID's support a small number of hosts.



The rest of the addresses are divided into two classes, D and E.

**Class D networks** are not assigned to the host. They are used for multicasting. The address range from 224.x.x.x to 239.x.x.x

**Class E** networks are experimental or reserved addresses. The address range from 240.x.x.x to 247.x.x.x

## Appendix C

## ARP Commands

ARP is the Internet layer protocol responsible for matching or obtaining the MAC (hardware) address that corresponds to a particular IP address. The ARP command allows the user to view the current contents of the ARP cache of the local computer (residing on the same network). Microsoft includes the ARP.EXE utility for viewing and modifying the ARP cache with its Windows products. The following ARP commands can be used to view cache entries:

- **arp -a** → Use this command to view all ARP cache entries.
- **arp -a** plus **IP address** → Use this command to view ARP cache entries associated with one particular interface on a network with multiple adapters.
- **arp -g** → Same as arp -a.
- **arp -N** → Use this command to display ARP entries for specific network interface.
- **arp -s** plus **IP address** plus **Physical address** → Use this command to manually add a permanent static entry to the ARP cache.
- **arp -d** → Use this command to manually delete a static entry.

**Note**

Ping the destination computer using IP address first before using the arp -a command.

The following window shows examples of arp commands and responses.

- Your computer has an IP address of **192.168.1.118**
- The destination computer has an IP address of **192.168.1.96**

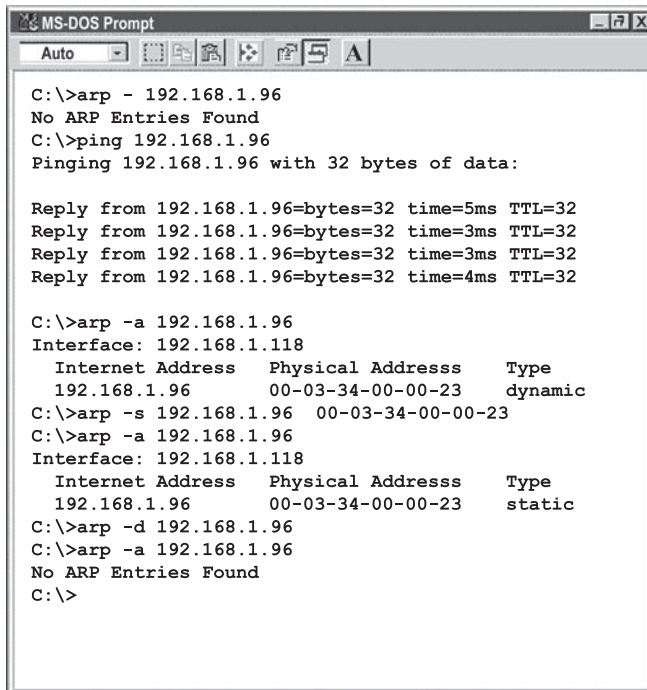

```
MS-DOS Prompt
Auto
C:\>arp - 192.168.1.96
No ARP Entries Found
C:\>ping 192.168.1.96
Pinging 192.168.1.96 with 32 bytes of data:

Reply from 192.168.1.96=bytes=32 time=5ms TTL=32
Reply from 192.168.1.96=bytes=32 time=3ms TTL=32
Reply from 192.168.1.96=bytes=32 time=3ms TTL=32
Reply from 192.168.1.96=bytes=32 time=4ms TTL=32

C:\>arp -a 192.168.1.96
Interface: 192.168.1.118
Internet Address  Physical Addressss  Type
192.168.1.96      00-03-34-00-00-23  dynamic
C:\>arp -s 192.168.1.96 00-03-34-00-00-23
C:\>arp -a 192.168.1.96
Interface: 192.168.1.118
Internet Address  Physical Addressss  Type
192.168.1.96      00-03-34-00-00-23  static
C:\>arp -d 192.168.1.96
C:\>arp -a 192.168.1.96
No ARP Entries Found
C:\>
```

Figure C.1 ARP Commands and Responses

## Appendix D

## IP Netmask

IP Netmask or Subnet Mask is a 32-bit pattern of ones and zeros used to determine network portion of an IP address from the host portion of the IP address. Subnet mask is a network ID that is created by borrowing bits from host portion of IP address and using them as part of a network ID. The table below shows a default subnet mask for address Classes A, B, and C. Each bit that is set to “1” in the subnet mask corresponds to the bit in the IP address that is to be used as the network ID. Each bit that is set to “0” in the subnet mask corresponds to a bit in the IP address that is to be used as the host ID.

Address Class	Mask Binary Value	Mask Decimal Value or Dotted Notation
Class A	11111111 00000000 00000000 00000000	255.0.0.0
Class B	11111111 11111111 00000000 00000000	255.255.0.0
Class C	11111111 11111111 11111111 00000000	255.255.255.0

If your network requires more network ID’s, you can extend the default subnet mask to include additional bits from the host ID. This allows for additional network ID’s within the network. The table below shows some examples of subnet masks and bits moved from the hosts ID to create a new subnet.

Mask Dotted Notation	Mask Binary	Mask Bits
<b>Class A</b>		
255.0.0.0 (Default)	11111111 00000000 00000000 00000000	0
255.192.0.0	11111111 11000000 00000000 00000000	2
255.224.0.0	11111111 11100000 00000000 00000000	3
255.240.0.0	11111111 11110000 00000000 00000000	4
255.248.0.0	11111111 11111000 00000000 00000000	5
255.252.0.0	11111111 11111100 00000000 00000000	6
255.254.0.0	11111111 11111110 00000000 00000000	7
255.255.0.0	11111111 11111111 00000000 00000000	8
255.255.128.0	11111111 11111111 10000000 00000000	9
255.255.192.0.0	11111111 11111111 11000000 00000000	10
.....	.....	.
255.255.255.252	11111111 11111111 11111111 11111100	22
<b>Class B</b>		
255.255.0.0 (Default)	11111111 11111111 00000000 00000000	0
255.255.192.0	11111111 11111111 11000000 00000000	2
.....	.....	.
255.255.255.252	11111111 11111111 11111111 11111100	14
<b>Class C</b>		
255.255.255.0 (Default)	11111111 11111111 11111111 00000000	0
255.255.255.192	11111111 11111111 11111111 11000000	2
.....	.....	.
255.255.255.254	11111111 11111111 11111111 11111100	6

To determine the number of valid hosts ID’s remaining after subnetting, use the following equation:  $2^n - 2$ , where n is the number of octet digits left after the subnet mask.

**Appendix E**

**ASCII Chart**

ASCII Char	Dec	Hex	Binary No Parity	ASCII Char	Dec	Hex	Binary No parity
NUL	00	00	00000000	@	64	40	01000000
SOH	01	01	00000001	A	65	41	01000000
STX	02	02	00000010	B	66	42	01000010
ETX	03	03	00000011	C	67	43	01000011
EOT	04	04	00000100	D	68	44	01000100
ENQ	05	05	00000101	E	69	45	01000101
ACK	06	06	00000110	F	70	46	01000110
BEL	07	07	00000111	G	71	47	01000111
BS	08	08	00001000	H	72	48	01001000
HT	09	09	00001001	I	73	49	01001001
LF	10	0A	00001010	J	74	4A	01001010
VT	11	0B	00001011	K	75	4B	01001011
FF	12	0C	00001100	L	76	4C	01001100
CR	13	0D	00001101	M	77	4D	01001101
SO	14	0E	00001110	N	78	4E	01001110
SI	15	0F	00001111	O	79	4F	01001111
DLE	16	10	00010000	P	80	50	01010000
DC1	17	11	00010001	Q	81	51	01010001
DC2	18	12	00010010	R	82	52	01010010
DC3	19	13	00010011	S	83	53	01010011
DC4	20	14	00010100	T	84	54	01010100
NAK	21	15	00010101	U	85	55	01010101
SYN	22	16	00010110	V	86	56	01010110
ETB	23	17	00010111	W	87	57	01010111
CAN	24	18	00011000	X	88	58	01011000
EM	25	19	00011001	Y	89	59	01011001
SUB	26	1A	00011010	Z	90	5A	01011010
ESC	27	1B	00011011	[	91	5B	01011011
FS	28	1C	00011100	\	92	5C	01011100
GS	29	1D	00011101	]	93	5D	01011101
RS	30	1E	00011110	^	94	5E	01011110
US	31	1F	00011111	_	95	5F	01011111
SP	32	20	00100000	`	96	60	01100000
!	33	21	00100001	a	97	61	01100001
"	34	22	00100010	b	98	62	01100010
#	35	23	00100011	c	99	63	01100011
\$	36	24	00100100	d	100	64	01100100
%	37	25	00100101	e	101	65	01100101
&	38	26	00100110	f	102	66	01100110
'	39	27	00100111	g	103	67	01100111
(	40	28	00101000	h	104	68	01101000
)	41	29	00101001	i	105	69	01101001
*	42	2A	00101010	j	106	6A	01101010
+	43	2B	00101011	k	107	6B	01101011
,	44	2C	00101100	l	108	6C	01101100
-	45	2D	00101101	m	109	6D	01101101
.	46	2E	00101110	n	110	6E	01101110

**Appendix E**

**ASCII Chart Continuation**

/	47	2F	00101111	o	111	6F	01101111
0	48	30	00110000	p	112	70	01110000
1	49	31	00110001	q	113	71	01110001
2	50	32	00110010	r	114	72	01110010
3	51	33	00110011	s	115	73	01110011
4	52	34	00110100	t	116	74	01110100
5	53	35	00110101	u	117	75	01110101
6	54	36	00110110	v	118	76	01110110
7	55	37	00110111	w	119	77	01110111
8	56	38	00111000	x	120	78	01111000
9	57	39	00111001	y	121	79	01111001
:	58	3A	00111010	z	122	7A	01111010
;	59	3B	00111011	{	123	7B	01111011
<	60	3C	00111100		124	7C	01111100
=	61	3D	00111101	}	125	7D	01111101
>	62	3E	00111110	~	126	7E	01111110
?	63	3F	00111111	DEL	127	7F	01111111

**ASCII Control Codes**

ASCII Char	Dec	Hex	Ctrl Key Equiv.	Definition	ASCII Char	Dec	Hex	Ctrl Key Equiv.	Definition
NUL	00	00	Ctrl @	Null Character	DC1	17	11	Ctrl Q	Data Control 1 - XON
SOH	01	01	Ctrl A	Start of Header	DC2	18	12	Ctrl R	Data Control 2
STX	02	02	Ctrl B	Start of Text	DC3	19	13	Ctrl S	Data Control 3 - XOFF
ETX	03	03	Ctrl C	End of Text	DC4	20	14	Ctrl T	Data Control 4
EOT	04	04	Ctrl D	End of Transmission	NAK	21	15	Ctrl U	Negative Acknowledge
ENQ	05	05	Ctrl E	Inquiry	SYN	22	16	Ctrl V	Synchronous Idle
ACK	06	06	Ctrl F	Acknowledge	ETB	23	17	Ctrl W	End of Trans Block
BEL	07	07	Ctrl G	Bell	CAN	24	18	Ctrl X	Cancel
BS	08	08	Ctrl H	Back Space	EM	25	19	Ctrl Y	End of Medium
HT	09	09	Ctrl I	Horizontal Tabulation	SUB	26	1A	Ctrl Z	Substitute
LF	10	0A	Ctrl J	Line Feed	ESC	27	1B	Ctrl [	Escape
VT	11	0B	Ctrl K	Vertical Tabulation	FS	28	1C	Ctrl \	File Separator
FF	12	0C	Ctrl L	Form Feed	GS	29	1D	Ctrl ]	Group Separator
CR	13	0D	Ctrl M	Carriage Return	RS	30	1E	Ctrl	Record Separator
SO	14	0E	Ctrl N	Shift Out	US	31	1F	Ctrl _	Unit Separator
SI	15	0F	Ctrl O	Shift In	SP	32	20		Space
DLE	16	10	Ctrl P	Data Link Escape					

## Appendix FiLog Error Messages

Table F-1 iLog Error Messages

Error #	Description	Note
-8003	User stopped logging readings.	
-10005	Failed to find the iServer.	Ethernet cable is disconnected, iServer is powered off, connections across the firewall require longer "connection to socket time out" setting.
-10006	Windows socket was closed.	
-10007	Windows socket error.	Wrong IP or wrong Port number was used.
-10008	The iServer failed to respond to a request.	Wrong IP or wrong Port number was used.
-10011	Response came empty.	No data was sent.
-10012	Device responded with "Serial Time Out" string.	Possibly the iLog is configured for wrong product model.
-10014	Terminal Server Mode when the Port is 1000.	Try Port 2000 in iLog configuration.
-15100	Error on obtaining the temperature reading.	Possibly the iLog is configured for wrong product model.
-15105	Error on obtaining the humidity reading.	Possibly the iLog is configured for wrong product model.
-15110	Error on obtaining the dew point reading.	Possibly the iLog is configured for wrong product model.

## Appendix G Java Runtime Environment Setup

If your computer does not have Java installed, please download from <http://java.sun.com>. You can change the Java setting by clicking its icon in Control Panel. To load the applet, you have to enable the web browser and disable cache.

### G.1 Java Runtime Environment 1.7 Setup instructions

1. Go to your computer's Control Panel. Open the Java Plug-in

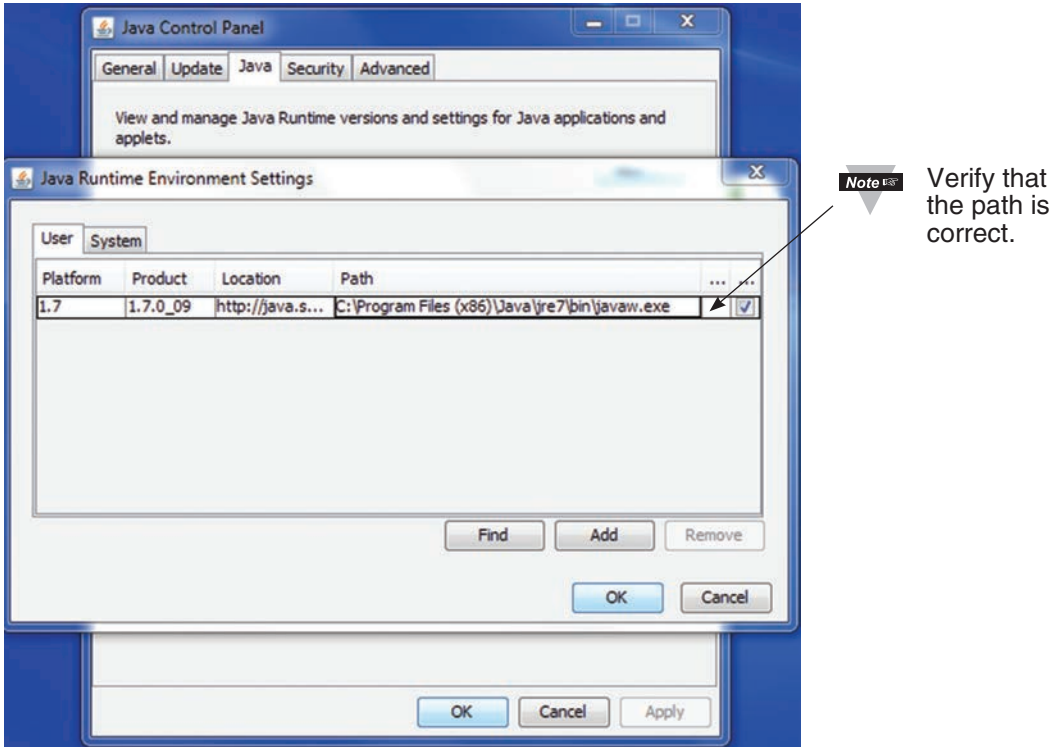

Figure G.1 Java 1.7 Screen Shot

## G.2 Browser Proxy Selection

### Accessing iServer within your internal network

- Usually when the computer and iServers are on an internal network, you will not use Proxy server access.
- You should un-check the “Use Browser Settings” option on the “Proxy” tab.

### Accessing iServers units using the internet

- Often the web browser will use Proxy server access to the internet. In such cases, the default Java runtime settings on the “Proxy” tab should suffice. The default setting is the “Use Browser Settings” option.
- If the default proxy setting doesn’t work, then you may have a situation where the proxy settings of the web browser are incorrect.

### Diagnostics:

If the web page of the iServer appears, then the HTTP Proxy is working fine.

If the data isn’t updated on the iServer upon selecting the “Readings” or “Chart” web page, there may be a problem with access through a winsock proxy server. In such cases your network administrator will need to provide the winsock proxy server and port #s. .

These values should be entered into the Socks line on the “Proxy” tab (of the Java Plugin control panel) or into the “connections” tab on the View,Internet Options dialog and make sure that the Proxy tab shows that the “Use Browser Settings” option is not selected (i.e. when you specify proxy connections in the Java Plugin control panel).

### Accessing iServer units over Peer-to-Peer network

A simple peer-to-peer network is setup by disconnecting from the main network (as users will often do when trying to do initial setup of the iServer) and then connecting the iServer to another computer using an ethernet hub, an ethernet switch, or a Cross-over cable connection.

Often when using a peer-to-peer network, the Java plugin and the web browser (such as Internet Explorer) have internet connections configured to connect through proxy servers. In such case, you will need to simply assign the final IP address on this peer to peer network and then view the iServer charts after connecting the iServer into the regular network. Otherwise you can disable the Java plug-in’s “Use Browser Settings” temporarily and then reconfigure the Java plug-in settings for regular network access after testing the iServer chart access on your peer-to-peer network.

The “Use Browser Settings” should not be selected. And the HTTP and Socks proxy entries should be blank. Also, setup the internet browser so that proxy servers are disabled.

## Appendix H

## Sensor Information

### H.1 Accuracy

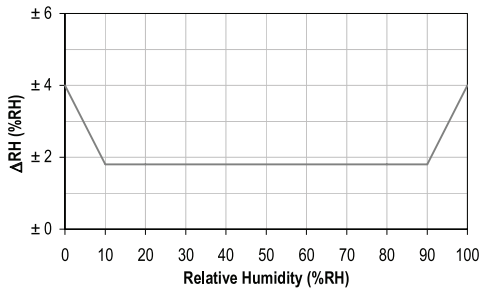

**Figure H.1**  
**RH Accuracy Chart**

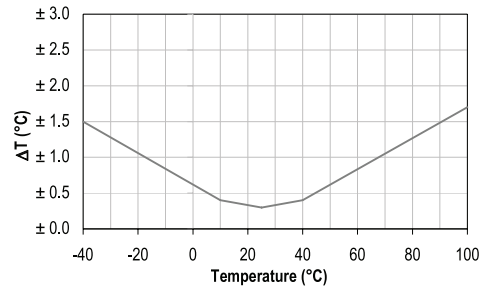
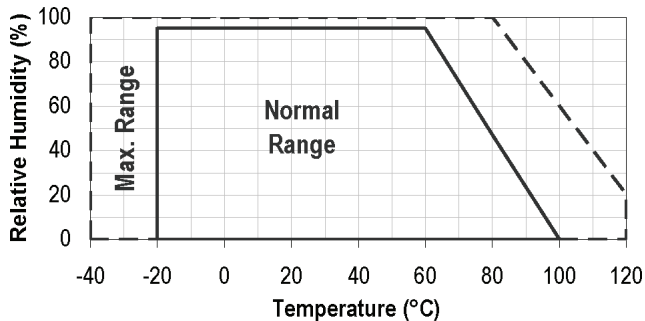

**Figure H.2**  
**Temperature Accuracy Chart**

Accuracies are tested at Manufacturer's Outgoing Quality Control at 25°C (77°F) and 3.3V. Values exclude hysteresis and non-linearity, and is only applicable to noncondensing environments.

### H.2 Operating Conditions

Sensor works stable within recommended normal range – see Figure. Long term exposures to conditions outside normal range, especially at humidity >80%RH, may temporarily offset the RH signal (+3 %RH after 60h). After return to normal range it will slowly return towards calibration state by itself. See **Section H.4** “Reconditioning Procedure” to accelerate eliminating the offset. Prolonged exposure to extreme conditions may accelerate aging.



**Figure H.3 Normal Range**

### H.3 Storage Conditions and Handling Instructions

It is of great importance to understand that a humidity sensor is not a normal electronic component and needs to be handled with care.

Chemical vapors at high concentration in combination with long exposure times may offset the sensor reading. For these reasons it is recommended to store the sensors in original packaging including the sealed ESD bag at following conditions: Temperature shall be in the range of 10°C – 50°C (0 – 80°C for limited time) and humidity at 20 – 60%RH (sensors that are not stored in ESD bags). For sensors that have been removed from the original packaging we recommend to store them in ESD bags made of PE-HD8.

In manufacturing and transport the sensors shall be prevented of high concentration of chemical solvents and long exposure times. Out-gassing of glues, adhesive tapes and stickers or out-gassing packaging material such as bubble foils, foams, etc. shall be avoided. Manufacturing area shall be well ventilated.

## **Appendix H                      Sensor Information (continued)**

### **H.4 Reconditioning Procedure**

As stated above extreme conditions or exposure to solvent vapors may offset the sensor. The following reconditioning procedure may bring the sensor back to calibration state:

**Baking: 100 – 105°C at < 5%RH for 10h**

**Re-Hydration: 20 – 30°C at ~ 75%RH for 12h.**

*(75%RH can conveniently be generated with saturated NaCl solution. 100 – 105°C correspond to 212 – 221°F, 20 – 30°C correspond to 68 – 86°F)*

### **H.5 Temperature Effects**

Relative humidity reading strongly depends on temperature. Therefore, it is essential to keep humidity sensors at the same temperature as the air of which the relative humidity is to be measured. In case of testing or qualification the reference sensor and test sensor must show equal temperature to allow for comparing humidity readings.

The packaging of sensor is designed for minimal heat transfer from the pins to the sensor. Still, if the sensor shares a PCB with electronic components that produce heat it should be mounted in a way that prevents heat transfer or keeps it as low as possible. Furthermore, there are self-heating effects in case the measurement frequency is too high.

### **H.6 Light**

The sensor is not light sensitive. Prolonged direct exposure to sunshine or strong UV radiation may age the housing.

### **H.7 Materials Used for Sealing / Mounting**

Many materials absorb humidity and will act as a buffer increasing response times and hysteresis. Materials in the vicinity of the sensor must therefore be carefully chosen.

Recommended materials are: Any metals, LCP, POM (Delrin), PTFE (Teflon), PE, PEEK, PP, PB, PPS, PSU, PVDF, PVF. For sealing and gluing (use sparingly): Use high filled epoxy for electronic packaging (e.g. glob top, underfill), and Silicone.

Out-gassing of these materials may also contaminate the sensor (see **Section H.3**).

Therefore try to add the sensor as a last manufacturing step to the assembly, store the assembly well ventilated after manufacturing or bake at 50°C for 24h to outgas contaminants before packing.

## Appendix J

## SNMP

**Table J-1 SNMP MIB-2**

Version: SNMPv1 Private Enterprise Number: .1.3.6.1.4.1.34089  
MIB-2 (RFC 1213) supported: System Group

Object Identifier (OID)	Object	Description	Access	Default
.1.3.6.1.2.1.1.1	sysDescr	The name and version identification of the product	Read-only	iTHX-SD/ X.XX X.XX is the firmware version
.1.3.6.1.2.1.1.2	sysObjectID	The authoritative identification of the network management subsystem contained in the product. This value is allocated within the SMI enterprises subtree (1.3.6.1.4.1).	Read-only	.1.3.6.1.4.1.34089.X.X X.X is the product system object ID
.1.3.6.1.2.1.1.3	sysUpTime	The time since the system was last re-initialized.	Read-only	
.1.3.6.1.2.1.1.4	sysContact	The contact person for this node, together with information on how to contact this person.	Read-write	None
.1.3.6.1.2.1.1.5	sysName	The hostname of this node.	Read-write	ithXXXX XXXX are the last 4 characters of the MAC address
.1.3.6.1.2.1.1.6	sysLocation	The physical location of this node.	Read-write	None
.1.3.6.1.2.1.1.7	sysServices	The set of services that this product primarily offers. The value is a sum of network layer services implemented.	Read-only	76 Services include application, end-to-end and internet

**Table J-2 SNMP Trap**

SNMP Trap (RFC 1157) version: SNMPv1  
Generic trap type: enterpriseSpecific(6)

Specific Trap	Alarm Description	Specific Trap	Alarm Description
0	Reading 1	7	SD card 10% memory left
1	Reading 2	8	Low battery
2	Reading 3	9	Relay 1 activated
3	Reserved	10	Relay 2 activated
4	Power reset	11	Reserved
5	Sensor disconnected	12	Reserved
6	Recording stopped		

## **PART 6**

### **APPROVALS INFORMATION**

#### **6.1 CE APPROVAL**

 This product conforms to the EMC directive 89/336/EEC amended by 93/68/EEC, and with the European Low Voltage Directive 72/23/EEC.

#### **Electrical Safety EN61010-1:2001**

Safety requirements for electrical equipment for measurement, control and laboratory.

#### **Basic Insulation**

#### **Pollution Degree 2**

#### **Dielectric withstand Test per 1 min**

- Input Power to Sensor Metal Body: none
- Input Power to Ethernet Output: 1500Vac
- Input Power to Relays: 1500Vac
- Ethernet Output to Relays: 1500Vac

#### **Measurement Category I**

*Category I are measurements performed on circuits not directly connected to the Mains Supply (power). Unit measures Air Temperature and Humidity.*

#### **Transients Overvoltage Surge (1.2/50uS Pulse)**

- Input Power: 500V Transients Overvoltage
- Ethernet: 1500V Transients Overvoltage

**Note:** *The ac/dc power adapter must have Safety Qualified Agency Approvals for CE with Double Insulation rating.*

*The ac/dc power adapter is 9Vdc.*

*The minimum output current rating is 500mA.*

#### **EMC EN61000-6-1:2001 (Immunity) and EN61000-6-3:2001 (Emissions)**

Immunity requirements for residential, commercial and light-industrial environments

- EMC Emissions Table 1, Class B
- EMC Immunity Table 1: Enclosure  
Table 2: Signal Lines Ports  
Table 3: Dc input/Dc output Ports

#### **EMC EN61326:1997 + and A1:1998 + A2:2001**

Immunity and Emissions requirements for electrical equipment for measurement, control and laboratory.

- EMC Emissions Table 4, Class B of EN61326
- EMC Immunity Table 1 of EN61326

**Note:** *I/O lines / sensor cables require shielded cables and these cables must be located on conductive cable trays or in conduits.*



Refer to the EMC and Safety installation considerations (Guidelines) of this manual for additional information.

#### **6.2 FCC**

This device complies with Part 15, Subpart B, Class B of the FCC rules.









# **OMEGA ENGINEERING, INC.**

## **3-Point Certificate of Conformance**

**Model Number: iTHX-SD**

OMEGA Engineering, Inc. certifies that the instrument referenced above has been fully inspected, tested and calibrated prior to shipment in accordance with the instruction manual supplied. OMEGA Engineering further certifies that this instrument meets or exceeds all of the published electrical, mechanical and operational performance characteristics.

All tests and calibrations were performed with instruments, equipment and standards which are traceable to the U.S. National Institute of Standards and Technology.

Specifically this instrument is accurate to within:

<b><u>VALUE</u></b>	<b><u>SPECIFICATIONS</u></b>
33% RH	± 2%
75% RH	± 2%
@ 25 °C	± 0.5°C

**One Omega Drive, P.O. Box 4047 • Stamford CT 06907-0047 • U.S.A.  
TEL: (203) 359-1660 • FAX: (203) 359-7700  
www.omega.com • e-mail: info@omega.com**

## WARRANTY/DISCLAIMER

OMEGA ENGINEERING, INC. warrants this unit to be free of defects in materials and workmanship for a period of **one (1) year** from the date of purchase. In addition to OMEGA's standard warranty period, OMEGA Engineering will extend the warranty period for **one (1) additional year** if the warranty card enclosed with each instrument is returned to OMEGA.

If the unit malfunctions, it must be returned to the factory for evaluation. OMEGA's Customer Service Department will issue an Authorized Return (AR) number immediately upon phone or written request. Upon examination by OMEGA, if the unit is found to be defective, it will be repaired or replaced at no charge. OMEGA's WARRANTY does not apply to defects resulting from any action of the purchaser, including but not limited to mishandling, improper interfacing, operation outside of design limits, improper repair, or unauthorized modification. This WARRANTY is VOID if the unit shows evidence of having been tampered with or shows evidence of having been damaged as a result of excessive corrosion; or current, heat, moisture or vibration; improper specification; misapplication; misuse or other operating conditions outside of OMEGA's control. Components which wear are not warranted, including but not limited to contact points, fuses, and triacs.

**OMEGA is pleased to offer suggestions on the use of its various products. However, OMEGA neither assumes responsibility for any omissions or errors nor assumes liability for any damages that result from the use of its products in accordance with information provided by OMEGA, either verbal or written. OMEGA warrants only that the parts manufactured by it will be as specified and free of defects. OMEGA MAKES NO OTHER WARRANTIES OR REPRESENTATIONS OF ANY KIND WHATSOEVER, EXPRESS OR IMPLIED, EXCEPT THAT OF TITLE, AND ALL IMPLIED WARRANTIES INCLUDING ANY WARRANTY OF MERCHANTABILITY AND FITNESS FOR A PARTICULAR PURPOSE ARE HEREBY DISCLAIMED. LIMITATION OF LIABILITY: The remedies of purchaser set forth herein are exclusive, and the total liability of OMEGA with respect to this order, whether based on contract, warranty, negligence, indemnification, strict liability or otherwise, shall not exceed the purchase price of the component upon which liability is based. In no event shall OMEGA be liable for consequential, incidental or special damages.**

CONDITIONS: Equipment sold by OMEGA is not intended to be used, nor shall it be used: (1) as a "Basic Component" under 10 CFR 21 (NRC), used in or with any nuclear installation or activity; or (2) in medical applications or used on humans. Should any Product(s) be used in or with any nuclear installation or activity, medical application, used on humans, or misused in any way, OMEGA assumes no responsibility as set forth in our basic WARRANTY/DISCLAIMER language, and, additionally, purchaser will indemnify OMEGA and hold OMEGA harmless from any liability or damage whatsoever arising out of the use of the Product(s) in such a manner.

## RETURN REQUESTS/INQUIRIES

Direct all warranty and repair requests/inquiries to the OMEGA Customer Service Department. BEFORE RETURNING ANY PRODUCT(S) TO OMEGA, PURCHASER MUST OBTAIN AN AUTHORIZED RETURN (AR) NUMBER FROM OMEGA'S CUSTOMER SERVICE DEPARTMENT (IN ORDER TO AVOID PROCESSING DELAYS). The assigned AR number should then be marked on the outside of the return package and on any correspondence.

The purchaser is responsible for shipping charges, freight, insurance and proper packaging to prevent breakage in transit.

FOR WARRANTY RETURNS, please have the following information available BEFORE contacting OMEGA:

1. Purchase Order number under which the product was PURCHASED,
2. Model and serial number of the product under warranty, and
3. Repair instructions and/or specific problems relative to the product.

FOR NON-WARRANTY REPAIRS, consult OMEGA for current repair charges. Have the following information available BEFORE contacting OMEGA:

1. Purchase Order number to cover the COST of the repair,
2. Model and serial number of product, and
3. Repair instructions and/or specific problems relative to the product.

OMEGA's policy is to make running changes, not model changes, whenever an improvement is possible. This affords our customers the latest in technology and engineering.

© Copyright 2013 OMEGA ENGINEERING, INC. All rights reserved. This document may not be copied, photocopied, reproduced, translated, or reduced to any electronic medium or machine-readable form, in whole or in part, without the prior written consent of OMEGA ENGINEERING, INC.

**TRADEMARK NOTICE:** ®, *omega.com*®,  OMEGA®, and  are Trademarks of OMEGA ENGINEERING, INC.

**PATENT NOTICE:** This product is covered by one or more of the following patents: U.S. Pat. No. Des. 336,895; 5,274,577/ CANADA 2052599; 2052600 / ITALY 1249456; 1250938 / FRANCE BREVET No. 91 12756 / SPAIN 2039150; 2048066 / UK PATENT No. GB2 249 837; GB2 248 954 / GERMANY DE 41 34398 C2. Other US and International Patents pending or applied for.

# Where Do I Find Everything I Need for Process Measurement and Control? **OMEGA...Of Course!** *Shop on line at [omega.com](http://omega.com)*

## **TEMPERATURE**

- Thermocouple, RTD & Thermistor Probes, Connectors, Panels & Assemblies
- Wire: Thermocouple, RTD & Thermistor
- Calibrators & Ice Point References
- Recorders, Controllers & Process Monitors
- Infrared Pyrometers

## **PRESSURE, STRAIN AND FORCE**

- Transducers & Strain Gauges
- Load Cells & Pressure Gauges
- Displacement Transducers
- Instrumentation & Accessories

## **FLOW/LEVEL**

- Rotameters, Gas Mass Flowmeters & Flow Computers
- Air Velocity Indicators
- Turbine/Paddlewheel Systems
- Totalizers & Batch Controllers

## **pH/CONDUCTIVITY**

- pH Electrodes, Testers & Accessories
- Benchtop/Laboratory Meters
- Controllers, Calibrators, Simulators & Pumps
- Industrial pH & Conductivity Equipment

## **DATA ACQUISITION**

- Data Acquisition & Engineering Software
- Communications-Based Acquisition Systems
- Plug-in Cards for Apple, IBM & Compatibles
- Datalogging Systems
- Recorders, Printers & Plotters

## **HEATERS**

- Heating Cable
- Cartridge & Strip Heaters
- Immersion & Band Heaters
- Flexible Heaters
- Laboratory Heaters

## **ENVIRONMENTAL MONITORING AND CONTROL**

- Metering & Control Instrumentation
- Refractometers
- Pumps & Tubing
- Air, Soil & Water Monitors
- Industrial Water & Wastewater Treatment
- pH, Conductivity & Dissolved Oxygen Instruments